

CATALOG



>Photoelectric
Sensors

DATALOGIC
THE VISION IS YOURS





DATALOGIC: SOLUTIONS FOR INDUSTRIAL AUTOMATION



Datalogic Industrial Automation is an industry-leader in products and solutions for material handling, traceability, inspection and detection applications.

With the acquisitions of Accu-Sort and PPT Vision in 2012, the company offers a comprehensive portfolio of products, technologies and solutions delivered by a team of skilled professionals dedicated in providing superior service to customers.

Datalogic is the partner of choice for organizations in the Industrial Automation market.

Factory Automation

- AUTOMOTIVE
- ELECTRONICS
- FOOD & BEVERAGE
- GENERAL MANUFACTURING
- HEALTHCARE - PHARMACEUTICAL

Transportation & Logistics

- AIRPORTS
- COURIER, EXPRESS PARCEL (CEP)
- POSTAL
- RETAIL DISTRIBUTION

Product portfolio

Datalogic Industrial Automation has the most comprehensive offering of products and solutions for traceability, inspection and detection applications in factory automation and logistics processes: industrial LASER scanners, cameras and vision systems, sensors, machine safety devices and LASER markers.

Identification

Even the most demanding and efficient automation of identification processes can leverage Datalogic Industrial Automation's leadership in the market. We manufacture the world's most comprehensive family of fixed-mount line and omnidirectional scanners.

We also offer the latest CCD vision technology with the world's largest installed base of CCD systems for bar code reading and dimensioning.

All of our AUTO-ID products and solutions leverage the broadest decoding library that has been developed through the years. Datalogic's comprehensive AUTO-ID portfolio is used in a wide range of applications and machines which are behind many of the everyday processes that keeps the global economy running.

Sensors & Safety

Datalogic Industrial Automation offers a best-in-class, comprehensive product portfolio of photoelectric and proximity sensors, rotary encoders, temperature controllers and measurement devices, as well as type 2 and type 4 safety light curtains.

These product lines provide solutions for applications involving color, contrast and luminescence, label detection, dimensional and distance measurement, in addition to machine safeguarding and access control in dangerous areas.

Machine Vision

The Datalogic Industrial Automation machine vision product line encompasses both hardware and software while covering a wide range of performance and price point requirements. The vision portfolio of products and solutions ranges from simple vision sensors to smart cameras and embedded vision systems.

Laser Marking

Laser Marking sources and systems provide value driven marking solutions for automotive, metal tools, medical, electronics and packaging. Datalogic Industrial Automation offers an extensive range of state-of-the-art technology, excellent performance and high reliability marking equipment.



PHOTOELECTRIC SENSORS

Datalogic has more than 40 years of experience in the sensors and safety sector, developing their first product, a **Photoelectric Sensor**, in 1972. Today, Datalogic is one of the largest manufacturers of sensor and safety products worldwide.

Datalogic is the market leader in Italy for photoelectric sensors and safety light curtains, ranking among the **top-10 manufacturers** in Europe by market share.

Datalogic's **Sensors and Safety** portfolio solves customer applications in **Factory Automation**, specializing in Processing and Packaging machinery, and Automated Material Handling Systems related to manufacturing industries such as Automotive, Electronics, Pharmaceutical, Food & Beverage, Paper and Printing, Wood-working, Ceramics, Glass, and Textiles.

Tubular, Miniature and Fiber Optic sensors for object detection in reduced space



Fork sensors for label detection for object detection in reduced space

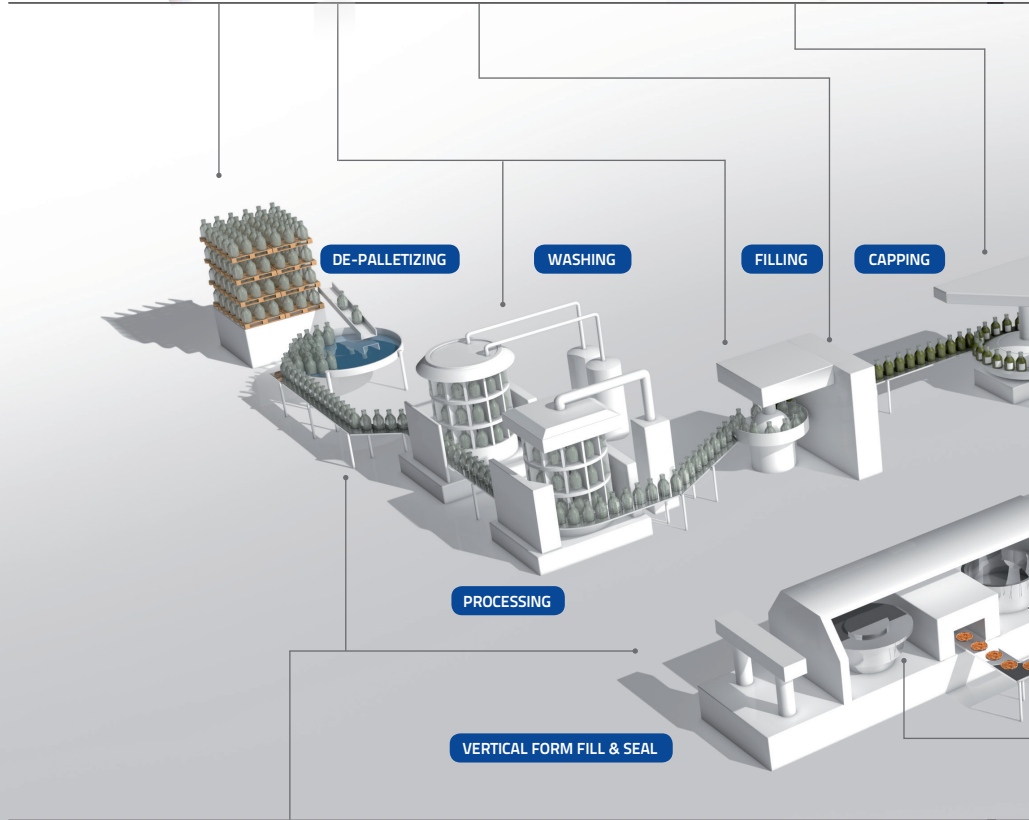

APPLICATIONS

- De-Palletizing
- Washing
- Filling
- Capping
- Labeling
- Case Packing
- Stretch-wrapping
- Palletizing
- Storage & Retrieval
- Cartoning
- Wrapping
- Vertical Form Fill & Seal
- Processing

Extended range of universal compact sensors for object detection



SENSOR PRODUCTS

SENSORS PRODUCT RANGE



- Inductive
- Ultrasonic
- Capacitive
- Temperature

Contrast and Luminescence sensors for registration marks detection



Area sensors for the detection of objects with different shape and dimensions



Maxi and Compact sensors for object detection

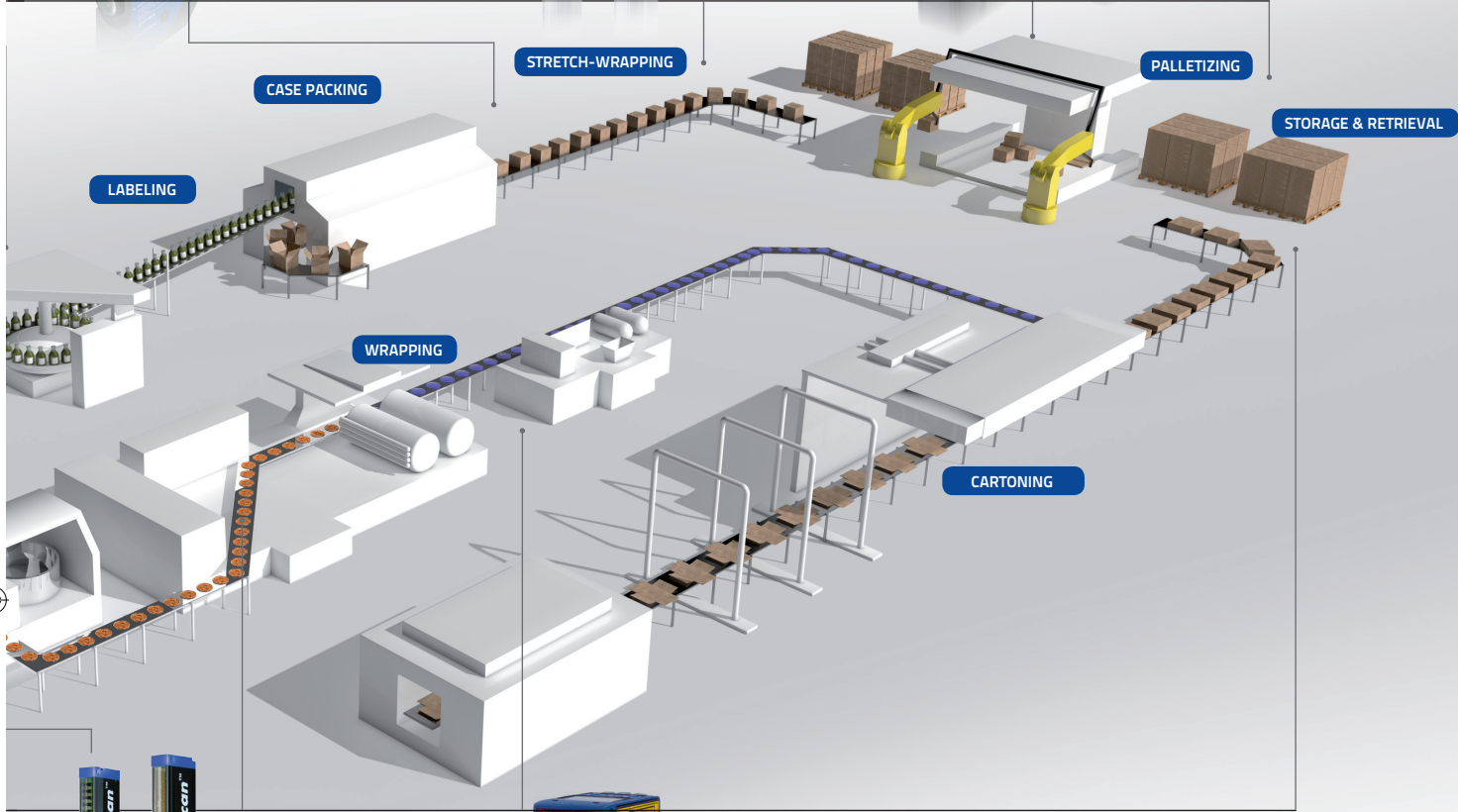

Dimensional sensors for height/width measurement and object positioning



TOF distance sensors for measurement and object positioning





INDEX

Photoelectric sensors	8
Selection chart	14
Reference guide	18
Tubular sensors	20
Miniature sensors	46
Compact sensors	86
Maxi sensors	128
Fiber optic sensors	138
Fork sensors	162
Contrast sensors	178
Luminescence sensors	190
Color & Contrast sensors	194
Area sensors	200
Dimension light grids	204
Distance sensors	212
Accessories	230





PHOTOELECTRIC SENSORS

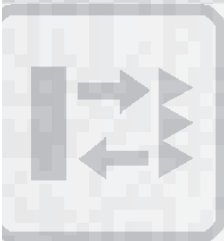
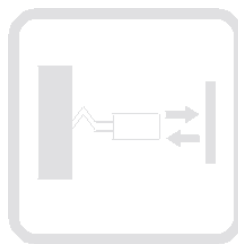
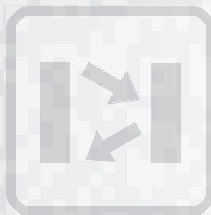
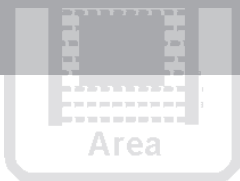

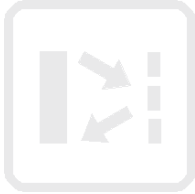
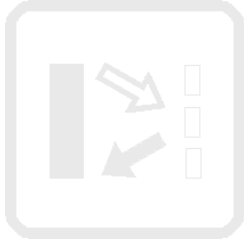

A Photoelectric sensor is a device used to detect the distance, absence or presence of an object, as well as to distinguish different items on the basis of their light absorption and reflection properties.

A photoelectric sensor consists of an emitter and receiver unit, coupled by either a modulated LED or LASER light beam.

Photoelectric sensors are available in three different functional types depending the environment and the detection objects physical properties: through beam, retroreflective, and proximity.

These sensors are ideal for generic industrial applications such as counting, presence control, or automatic positioning.

In addition, Datalogic offers solutions in a variety of applications such as contrast reading, distance and area measuring, as well as luminescence and color detection.

PHOTOELECTRIC SENSORS

PHOTOELECTRIC SENSORS

THROUGH BEAM

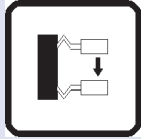
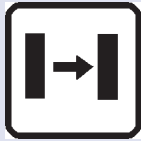

The light emitter and receiver are contained in two different housings and installed facing each other. The light beam released by the emitter directly hits the receiver; every object interrupting the beam is therefore detected. This system is used to obtain significant signal differences (when the light directly hits the receiver and when the object interrupts the beam) with the highest Excess Gain and the largest operating distance (up to 60 m). Moreover, these sensors can operate in the harshest working conditions, such as dirty or dusty environments. The through beam optic function typically operates in the dark mode: the output is activated when the object interrupts the light beam between emitter and receiver.

RETROREFLECTIVE

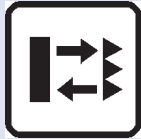

Both emitter and receiver are located inside the same housing for retro-reflective photoelectric sensors. Utilizing a prismatic reflector, the emitted light beam is reflected onto the receiver, detecting the object when it interrupts the light beam.

POLARIZED RETROREFLECTIVE



In polarized retroreflective sensors, the emitted light is polarized on a vertical plane through a polarization filter. The prismatic reflector rotates the light plane by 90° . A polarization filter placed on the receiver selects only the horizontal plane reflected by the prismatic reflector, ignoring the light reflected by other light sources. This technique guarantees a reliable signal reception, reaching significant distances.

RETROREFLECTIVE FOR TRANSPARENT

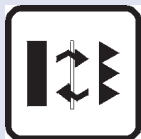

For the detection of transparent objects, such as PET bottles or Mylar sheets, a low-hysteresis polarized retroreflective model (which detects small signal differences) can be used.

These sensors elaborate the slight signal differences received when the light beam passes through a transparent object, avoiding false detections due to the nature of this kind of targets.

This technique mostly suits applications for the detection of objects positioned at considerable distances, where a prismatic reflector can be installed.

Typically, the operating distance proportionally increases with the reflector's dimensions.

DIFFUSE PROXIMITY

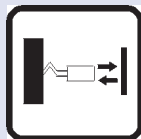

In photoelectric sensors with this optic function, both emitter and receiver are placed inside the same housing. These sensors work with weaker signals because the emitted light beam is reflected to the receiver by the object. As a consequence, the excess gain and the operating distance are reduced. However objects are detected without a prismatic reflector, making installations quick and easy.

FIXED FOCUS PROXIMITY



Fixed focus proximity sensors have a simple fixed background suppression distance, beyond which no objects are detected. The fixed triangulation of the optics greatly reduces the detection distance of reflective objects. The visible red emission simplifies the sensor's installation.

BACKGROUND SUPPRESSION



Background suppression sensors detect objects while avoiding reflections from the background. When the sensor is used for the first time, the proper background suppression distance has to be set through a distance adjustment trimmer. Once the background has been acquired, the objects can be detected regardless of their color. Background suppression sensors are not very reliable with highly clear, transparent or shiny objects.

BACKGROUND SUPPRESSION

FOR CLEAR DETECTION



Background suppression technology often has difficulty reliably detecting transparent, clear, or shiny objects. These objects generate false detections due to their highly reflective surfaces. Datalogic's patented background suppression technology guarantees reliable and repeatable detection, ignoring the false detections. Models are available with LED emission, ideal for reflections caused by moving surfaces such as conveyor belts, or with LASER emission for the detection of small objects on fixed or highly reflective backgrounds. Since background suppression sensors do not require a prismatic reflector, these sensors can substitute for a polarized retroreflective sensor for transparent objects for shorter distances.

PHOTOELECTRIC SENSORS

CONTRAST

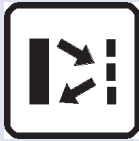

Contrast sensors distinguish the received light beams on the basis of their degrees of intensity, which depend on the color or material of the detected surfaces. A typical application of these sensors is the detection of colored registration marks used in packaging machines to synchronize the folding, cutting and welding phases. In presence of colored surfaces, the contrast is highlighted using a LED with colored light emission, typically a selectable red, green or blue LED. The white light emission allows to detect very slight contrasts in similar materials and colors.

LUMINESCENCE



Luminescence sensors emit invisible ultraviolet light, which is reflected at a higher wavelength (minor energy) on the fluorescent and phosphorescent surface, shifting into the visible light spectrum. The ultraviolet emission is modulated and the visible light reception is synchronized. The maximum immunity against external interferences, like reflections caused by very shiny surfaces, is obtained and fluorescent targets, invisible to the human eye, can be detected. Luminescence sensors are used in several industrial fields to detect items containing phosphorous such as labels on glass or mirrors, fluorescent marks marked on tiles, fluorescent glues on paper, cutting and sewing guides, as well as fluorescent paints or lubricants.

FORK

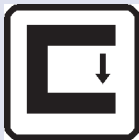

A fork sensor, is based on a particular model of the through beam sensor, where emitter and receiver are placed opposite to each other on the internal sides of an 'U-shaped' housing. Any target passing through the internal slot interrupts the beam and is detected. The most typical fork sensor applications are hole/teeth detection on wheels, label detection on thin supports, and control of edge and continuity of sheets of labels or tapes. The emission is generally infrared or red light in order to detect colored registration marks on translucent films.

COLOR



The color of an object is identified according to the different reflection coefficients obtained with the red (R), green (G) and blue (B) light emissions. For instance, yellow is characterized by R=50% G=50% B=0% reflections, orange by R=75% G=25% B=0%, pink by R=50% G=0% B=0%, the combinations are infinite. Color sensors cover a wide variety of applications, ranging from quality and process controls to automatic material handling for the identification, orientation, and selection of objects according to their color.

DISTANCE



Datalogic distance sensors are based on Time of Flight (T.O.F.): the distance is calculated on the basis of the time between the moment the LASER pulse is generated and the moment the emitted light is reflected off the object, back to the sensor. These sensors are generally used to measure an object's distance within a selected range, while the output is linearly scaled to the analog signal (4...20mA). This technology provides high precision and fast measurements in many applications, such as automatic warehousing (to drive industrial vehicles and avoid collisions), packaging and material handling.

AREA/DIMENSION LIGHT GRIDS

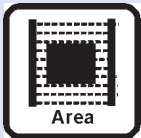

Area and Dimension light grids utilize several light beams for area or dimensional measurements of objects. An object's area and size are measured using parallel cross-beams, which identify obscured beams, providing accurate information to a host GUI or PC. Models of light grids vary by length to match each application requirements.

SELECTION CHART

UNIVERSAL PHOTOE

		TUBULAR		MINIATURE				
		S15	S50/S51	SMAI	S3Z	S40	S41	S45
MAX OPERATING DISTANCE								
Through beam		0...20 m	0...30 m 0...60 m	0...2 m	0...15 m 0...30 m		0,1...6 m	0...15 m 0...20 m
Retroreflective		0,1...5 m	0,1...5 m	0,05...1,5 m				
Polarized retroreflective		0,1...4 m	0,1...4,5 m 0,1...16m	0,1...1 m	0,05...4 m 0,3...10 m	0,1...2,5 m 0,1...6 m	0,1...2,5 m	0,1...7 m 0...2 m (coaxial) 0,1...15 m
Retroreflective for transparent		0,1...0,8 m	0,1...1,7 m		0...2 m	100...700 mm	100...700 mm	0...2 m
Diffuse proximity		1...100 mm 1...350 mm 1...1000 mm	0...100 mm 0...400 mm 0...700 mm 0...350 mm		5...150 mm 0...700 mm	5...300 mm 5...150 mm	2...350 mm	0...800 mm 1...250 mm
Fixed focus		0...50 mm	100 mm	3...15 mm 3...20 mm 3...30 mm 3...50 mm			110 mm	
Background suppression		40...120 mm	0...100 mm		0...300 mm 0...300 mm	15...100 mm 15...60 mm		1...200 mm 3...400 mm 4...120 mm
Fiber optic			0...100 mm (through beam) 0...30 mm (diffuse proximity)					
Contrast			10 ±2 mm					10 ±2 mm
Luminescence			0...20 mm					
Page		20	28	46	50	58	64	70

(*) The maximum operating distance is determined by the optic fiber and accessory lens used and the response speed selected in the specific model

The table shows the maximum operating distance reached by different sensors models. Some measures indicate only the highest performances obtained by the corresponding sensor. C operating distance values might be available for the same series and some optic functions might be carried out through LED or LASER emission, reaching different distances. For more s information refer to the dedicated product page in this guide or download datasheets and manuals from our website (www.datalogic.com)







INDUCTIVE SENSORS

	COMPACT					MAXI		FIBER OPTIC		
	S100	S8	S6	S60	S62	S90	S300 PA	S300 PR	S7	S70
										
Range	0...12 m	0...25 m	20 m	0...20 m 0...60 m 	0...25 m	0...60 m 	0...50 m	0...60 m	0...300 mm (*)	0...1740 mm (*)
Resolution	0,01...8 m		0,1...6 m		0,1...13 m		0,1...15 m			
Switching Frequency	0,01...3 m 0,01...5,5 m	0...5 m 0...10 m 	0,1...5 m	0,1...8 m 0...4 m (coaxial)  0,1...20 m 	0,1...8 m 0,3...20 m 	0...3 m 0,1...6 m 0,1...20 m 	0,1...10 m	0,1...22 m		
Response Time		0...0,8 m 0...2 m		0...2 m (coaxial)		0...1,5 m				
Mounting	2...300 mm 2...500 mm	0...500 mm	10...900 mm 10...2000 mm	0...100 cm 0...200 cm (long range)  0...60 cm	0...900 mm 0...2000 mm  0...900 mm 	10...1000 mm 50...2000 mm 0...600 mm 	50...2000 m	0...5000 mm	0...100 mm (*)	0...550 mm (*)
Mounting Height	70 mm									
Mounting Distance	0...100 mm 	50...300 mm 20...200 mm 	10...100 mm 30...250 mm 100...500 mm	7...20 cm  5...10 cm	30...300 mm 60...600 mm 60...1200 mm 200...2000 mm 30...1500 mm  50...350 mm 	20...200 mm 5...100 mm 	0,2...2 m	400...2500 mm		
Mounting Hole		9 ±2 mm		19 mm +/-2 mm (white)		19 ±2 mm				
Mounting Hole Diameter		10...20 mm		0...40 mm		0...40 mm				
Weight	78	86	94	100	110	118	128	134	140	144

isor. Other
iore specific

SELECTION CHART

APPLICATION PHOTOELECTRIC

	FORK				CONTRAST	
	SR21	SR23	SRF	SRX3	TLμ	TL46
MAX OPERATING DISTANCE						
Slot (width)	2 mm	5 mm	30, 50, 80, 120 mm	4 mm		
Contrast					6...60 mm (*)	9 ±3 mm (*)
Luminescence						
Color & Contrast						
Area						
Dimensional						
Distance						
Page	162	166	170	174	178	184



(*) The maximum operating distance is determined by the lens used in the specific model

The table shows the maximum operating distance reached by different sensors models. Some measures indicate only the highest performances obtained by the corresponding sensor. Other operating distance values might be available for the same series and some optic functions might be carried out through LED or LASER emission, reaching different distances. For more specific information refer to the dedicated product page in this guide or download datasheets and manuals from our website (www.datalogic.com)

ELECTRIC SENSORS

LUMINESCENCE	COLOR & CONTRAST	AREA	DIMENSION LIGHT GRIDS		DISTANCE			
LD-46	S65	AS1	DS1	DS2	S65-M	S80	S81	S85
								
	12...20 mm							
10...50 mm (*)								
	5...45 mm							
		0,3...3 m						
			0,15...4 m	0,3...10 m				
					0,3...5m (white 90%)	0,3...100,3 m	0,3...4 m	0,2...20 m
190	194	200	204	208	212	216	220	224

ACCESSORIES

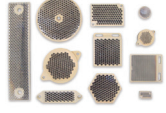
	FIBER OPTIC	CONNECTORS	REFLECTORS
	OF/OFA 	CS 	R 
Page	156	230	232

REFERENCE GUIDE

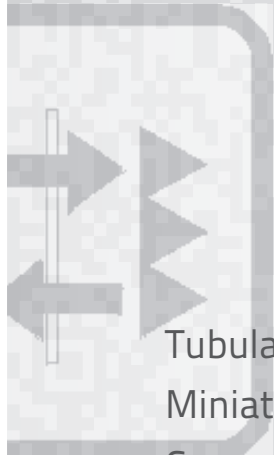

Tubular
Miniature
Compact
Maxi

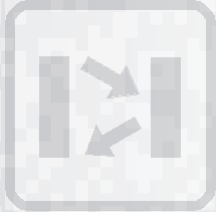

Fiber optic

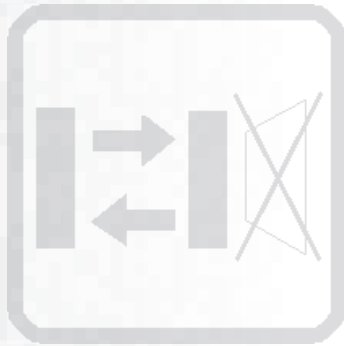

Fork

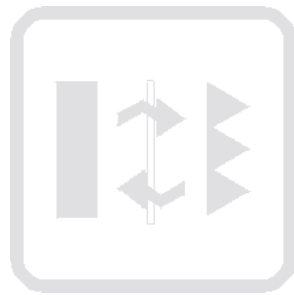

Contrast

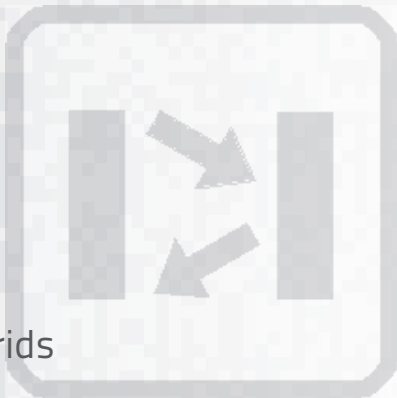

Luminescence

Color & Contrast

Area



Dimension light grids

Distance

Accessories

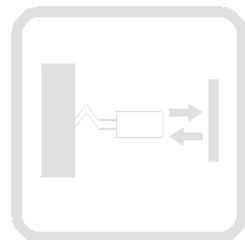

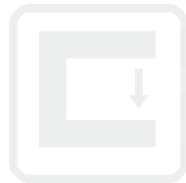
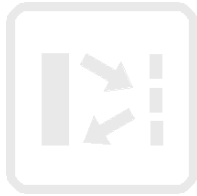
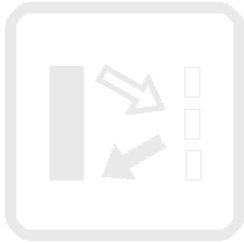

REFERENCE GUIDE



TUBULAR SENSORS

S15

Plastic and stainless steel tubular M18 photoelectric sensors every environment

- Short case models for cost and space savings
- Plastic and stainless steel case with IP69K protection
- All optic functions at optimal operating distances
- Models with fixed settings or adjustment trimmer
- Cable, M12 connector and pig-tail models



APPLICATIONS

- Processing and Packaging machinery
- Assembling and Conveyor lines



(*) Stainless steel models.
ATEX II 3DG

S15		
Through beam		0...20 m
Retroreflective (on R2 reflector)		0,1...5 m
Polarized retroreflective		0,1...4 m
Retroreflective for transparent (on R2 reflector)		0,1...0,8 m
Diffuse proximity		short distance 0...100 mm
		medium distance 0...350 mm
		long distance 1 m
Fixed focus		0...50 mm
Background suppression		40...120 mm
Power supply	Vdc	10...30 V
	Vac	
	Vac/dc	
Output	PNP	▪
	NPN	▪
	NPN/PNP	
	relay	
	other	
Connection	cable	▪
	connector	▪
	pig-tail	▪
Approximate dimensions (mm)		M18x44 / 48
Housing material		ABS, INOX AISI 316L
Mechanical protection		IP65 - IP67 - IP69K

TECHNICAL DATA

Power supply	12 ... 30 Vdc (limit values)
Ripple	2 Vpp max.
Consumption	25 mA max.
Light emission	red LED 660 nm (mod. S15...B/D/T/M) IR LED 880 nm (mod. S15...A/C/G)
Setting	mono-turn trimmer (mod. S15...A01/B01/Cx1/T01/F01) and 4 turns (mod. S15...M01)
Operating mode	white wire or pin 2 not connected: LIGHT mode (mod. S15...C/D/M)/DARK mode (mod. S15...A/B/T/F) white wire or pin 2 connected to: 0 V DARK mode, +Vcc LIGHT mode
Indicators	yellow OUTPUT LED green STABILITY LED, POWER LED (mod. S15...G)
Output	PNP or NPN
Output current	100 mA max.
Saturation voltage	2 V max.
Response time	1 ms (mod. S15...A/B/C/T/M) 2 ms (mod. S15...F) 500 µs (mod. S15...D)
Switching frequency	500 Hz (mod. S15...A/B/C/T/M) 250 Hz (mod. S15...F) 1 kHz (mod. S15...D)
Connection	M12 4-pole connector, 2 m cable Ø 4 mm, 150 mm length Ø 4 mm cable with M12 4-pole connector (pig-tail vers.)
Dielectric strength	500 Vac 1 min., between electronics and housing
Insulation resistance	>20 MΩ 500 Vdc, between electronics and housing
Mechanical protection	IP65, IP67, IP69K
Ambient light rejection	according to EN 60947-5-2
Vibrations	0.5 mm amplitude, 10 ... 55 Hz frequency, for each axis (EN60068-2-6)
Housing material	ABS TERLURAN, INOX AISI 316L (mod. S15-PA) - (mod. S15-NA)
Lens material	plastic PMMA
Operating temperature	-25 ... 55°C
Storage temperature	-25 ... 70°C
Weight	40 g max. conn. vers., 55 g max. cable vers., 35 g max. pig-tail vers.

CONNECTIONS

CABLE AND PIG-TAIL



M12 CONNECTOR

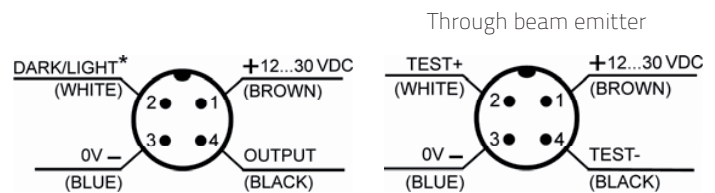

TUBULAR SENSORS

DIMENSIONS

PLASTIC

M12 connector version

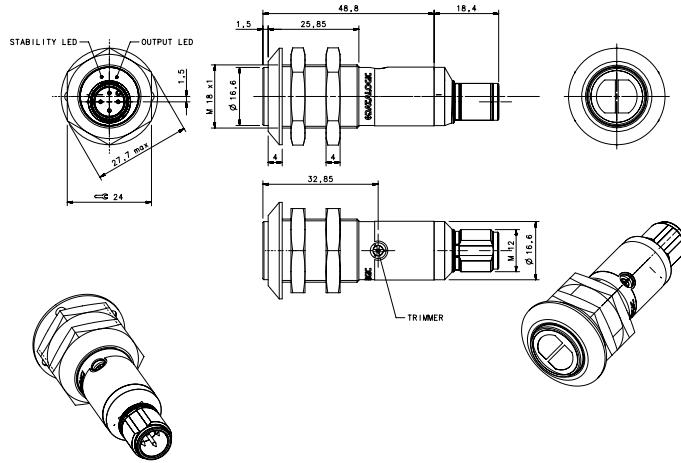

Cable version

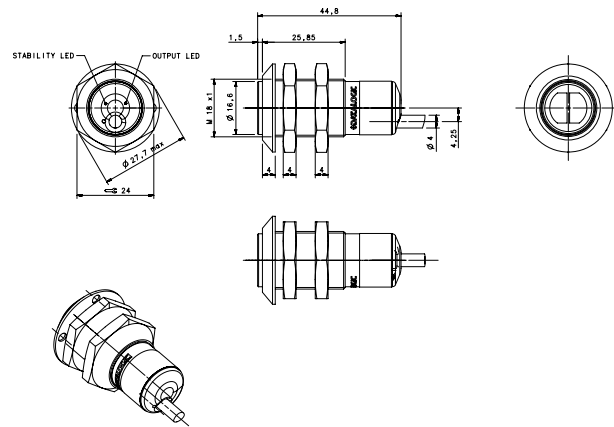

Through beam emitter - M12 connector version

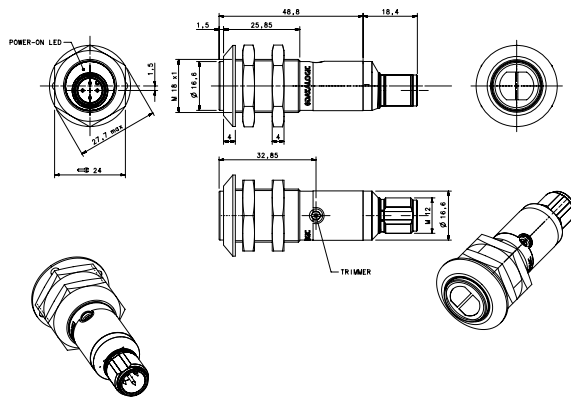

Background suppression - M12 connector version

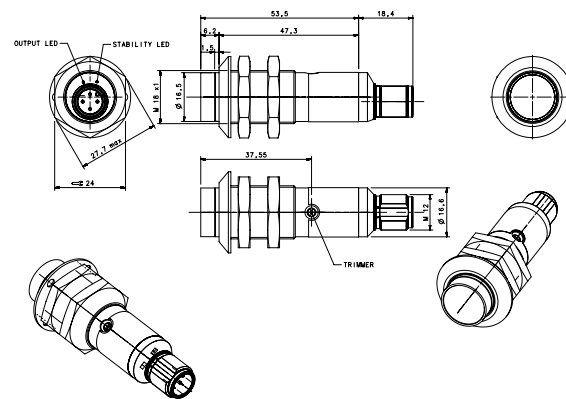

Through beam emitter - cable version

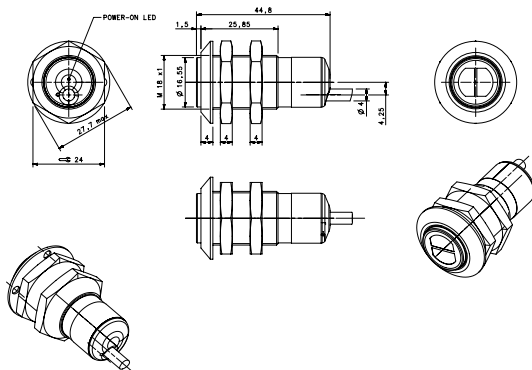

Diffuse proximity - cable version

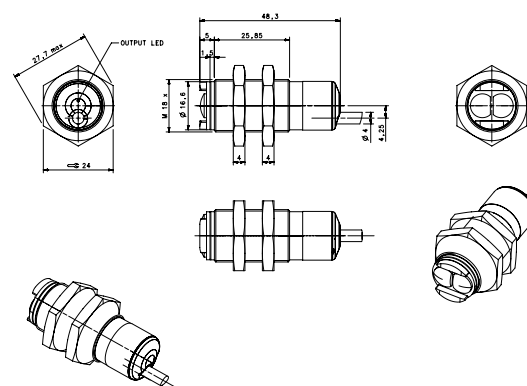

STAINLESS STEEL

M12 connector version

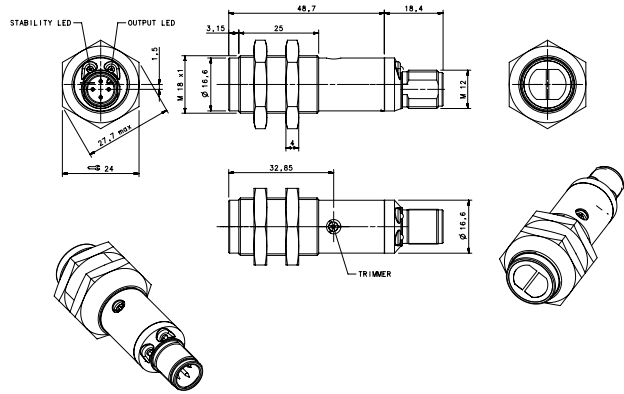

Through beam emitter - M12 connector version

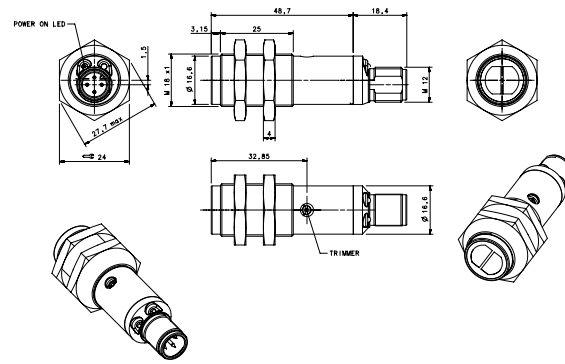

Background suppression - M12 connector version

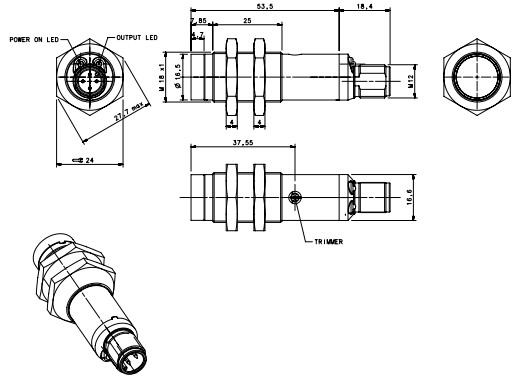

Pig-tail version

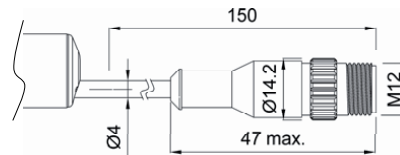

INDICATORS AND SETTINGS

Plastic/metal case with trimmer, M12 connector

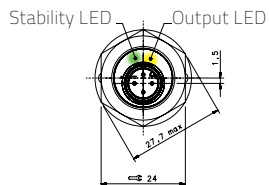

A01, B01, C11, C31, T01, F01, M01

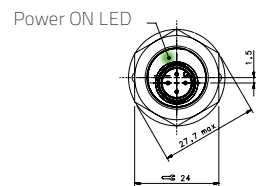

G01

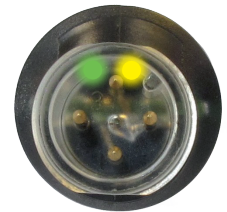
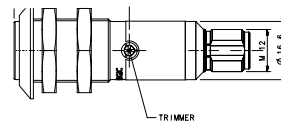

Plastic, no trimmer, Cable, Pig Tail

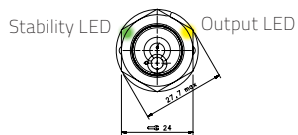

A00, B00, C10, C00, T01, D50

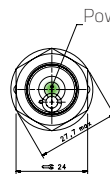

G00

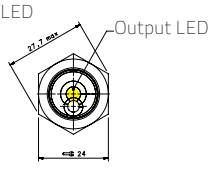

F00

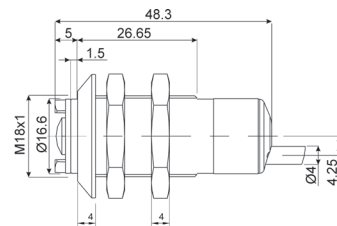

TUBULAR SENSORS

DETECTION DIAGRAMS

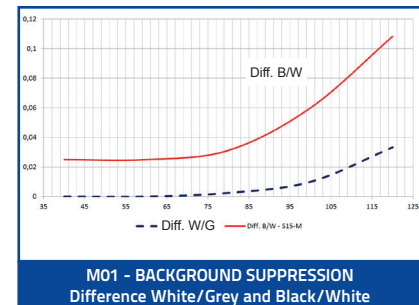
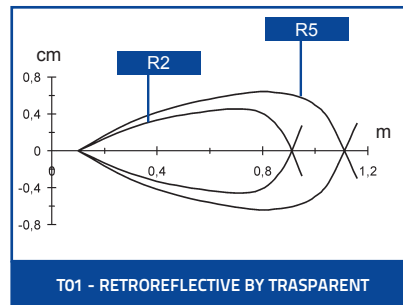
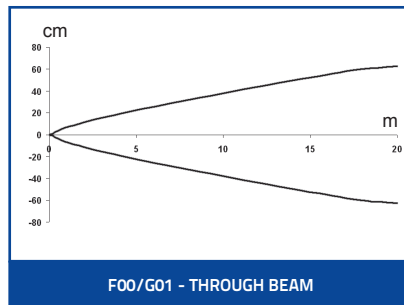
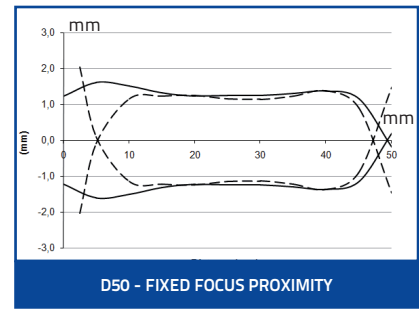
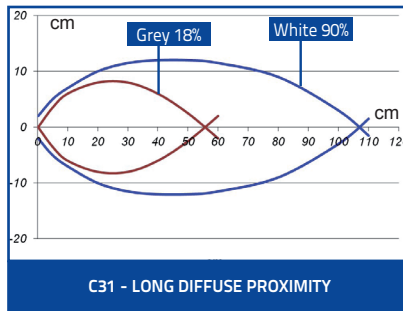
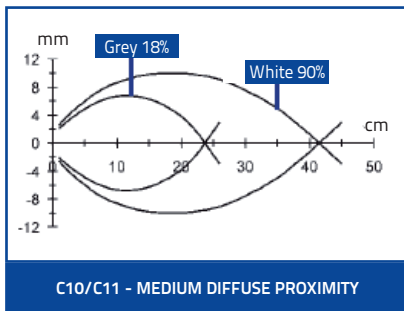
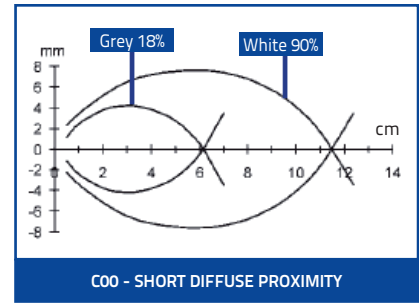
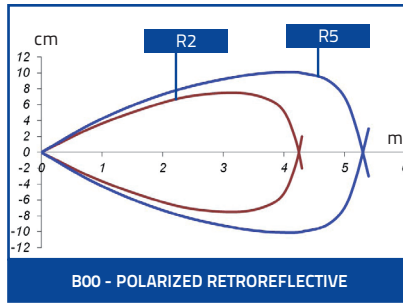
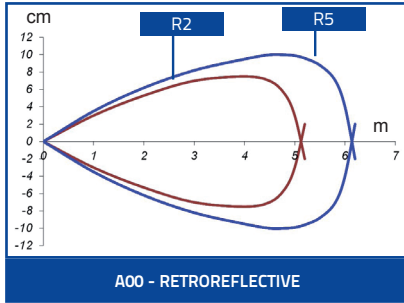

MODEL SELECTION AND ORDER INFORMATION

OPTIC FUNCTION	HOUSING	CONNECTION	OUTPUT	MODEL	ORDER No.
Retroreflective	Plastic	2 m cable	NPN	S15-PA-2-A00-NK	952301051
			PNP	S15-PA-2-A00-PK	952301001
		M12 connector	NPN	S15-PA-5-A01-NK	952301300
			PNP	S15-PA-5-A01-PK	952301220
		pig-tail	NPN	S15-PA-3-A00-NK	952301161
			PNP	S15-PA-3-A00-PK	952301111
	Stainless Steel	M12 connector	NPN	S15-NA-5-A01-NK	952301450
			PNP	S15-NA-5-A01-PK	952301370
Polarized Retroreflective	Plastic	2 m cable	NPN	S15-PA-2-B00-NK	952301061
			PNP	S15-PA-2-B00-PK	952301011
		M12 connector	NPN	S15-PA-5-B01-NK	952301310
			PNP	S15-PA-5-B01-PK	952301230
		pig-tail	NPN	S15-PA-3-B00-NK	952301171
			PNP	S15-PA-3-B00-PK	952301121
	Stainless Steel	M12 connector	NPN	S15-NA-5-B01-NK	952301460
			PNP	S15-NA-5-B01-PK	952301380
Diffuse proximity (short distance)	Plastic	2 m cable	NPN	S15-PA-2-C00-NK	952301071
			PNP	S15-PA-2-C00-PK	952301021
		pig-tail	NPN	S15-PA-3-C00-NK	952301181
			PNP	S15-PA-3-C00-PK	952301131
Diffuse proximity (medium distance)	Plastic	2 m cable	NPN	S15-PA-2-C10-NK	952301081
			PNP	S15-PA-2-C10-PK	952301031
		M12 connector	NPN	S15-PA-5-C11-NK	952301330
			PNP	S15-PA-5-C11-PK	952301250
		pig-tail	NPN	S15-PA-3-C10-NK	952301191
			PNP	S15-PA-3-C10-PK	952301141
	Stainless Steel	M12 connector	NPN	S15-NA-5-C11-NK	952301480
			PNP	S15-NA-5-C11-PK	952301400
Diffuse proximity (long distance)	Plastic	M12 connector	NPN	S15-PA-5-C31-NK	952301340
			PNP	S15-PA-5-C31-PK	952301260
	Stainless Steel		NPN	S15-NA-5-C31-NK	952301490
			PNP	S15-NA-5-C31-PK	952301410
Fixed focus	Plastic	2 m cable	NPN	S15-PA-2-D50-NK	952301530
			PNP	S15-PA-2-D50-PK	952301520
		pig-tail	NPN	S15-PA-3-D50-NK	952301550
			PNP	S15-PA-3-D50-PK	952301540
Through beam receiver	Plastic	2 m cable	NPN	S15-PA-2-F00-NK	952301091
			PNP	S15-PA-2-F00-PK	952301041
		M12 connector	NPN	S15-PA-5-F01-NK	952301360
			PNP	S15-PA-5-F01-PK	952301280
		pig-tail	NPN	S15-PA-3-F00-NK	952301201
			PNP	S15-PA-3-F00-PK	952301151
	Stainless Steel	M12 connector	NPN	S15-NA-5-F01-NK	952301510
			PNP	S15-NA-5-F01-PK	952301430
Through beam emitter	Plastic	2 m cable	-	S15-PA-2-G00-XG	952301101
		M12 connector	-	S15-PA-5-G01-XG	952301290
		pig-tail	-	S15-PA-3-G00-XG	952301211
	Stainless Steel	M12 connector	-	S15-NA-5-G01-XG	952301440
Background suppression	Plastic	M12 connector	NPN	S15-PA-5-M01-NK	952301350
			PNP	S15-PA-5-M01-PK	952301270
	Stainless Steel		NPN	S15-NA-5-M01-NK	952301500
			PNP	S15-NA-5-M01-PK	952301420
Transparent	Plastic	M12 connector	NPN	S15-PA-5-T01-NK	952301320
			PNP	S15-PA-5-T01-PK	952301240
	Stainless Steel		NPN	S15-NA-5-T01-NK	952301470
			PNP	S15-NA-5-T01-PK	952301390

TUBULAR SENSORS

ACCESSORIES

ST-5010

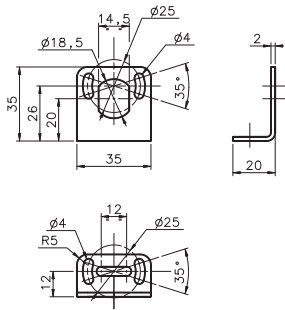

ST-5011

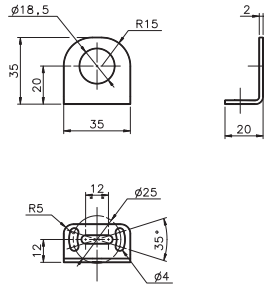

ST-5012

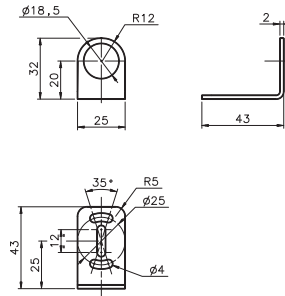

ST-5017

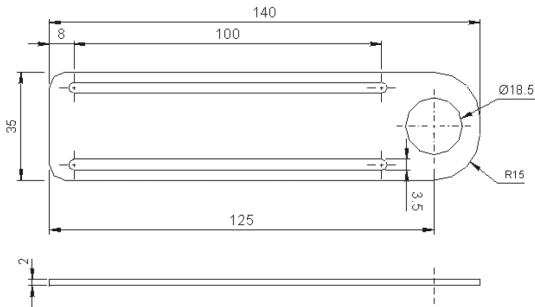

SWING-18

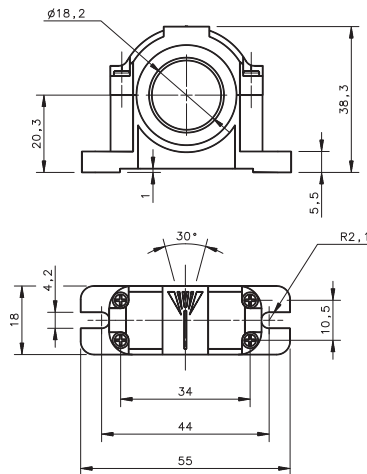

PLASTIC NUT

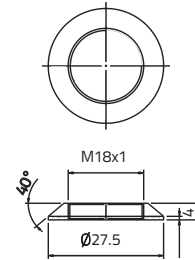

SP-40

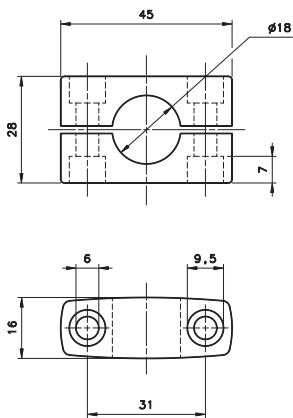

mm

MODEL	DESCRIPTION	ORDER No.
ST-5010	M18/14 mounting bracket	95ACC5230
ST-5011	M18 mounting bracket short	95ACC5240
ST-5012	M18 mounting bracket long	95ACC5250
ST-5017	M18 mounting bracket	95ACC5270
ST1218	M12/M18 mounting brackets	95ACC3340
ST1830	M18/M30 mounting brackets	95ACC3350
SP-40	mounting bracket tubular	95ACC1370
SWING-18	Adjustable support for M18 tubular sensors	895000006
PLASTIC NUT	flared mounting nut	95ACC2630

CABLES

TYPE	DESCRIPTION	LENGTH	MODEL	ORDER No.
Axial M12 Connector	4-pole, grey, P.V.C.	3 m	CS-A1-02-G-03	95A251380
		5 m	CS-A1-02-G-05	95A251270
		7 m	CS-A1-02-G-07	95A251280
		10 m	CS-A1-02-G-10	95A251390
	4-pole, P.U.R.	2 m	CS-A1-02-R-02	95A251540
		5 m	CS-A1-02-R-05	95A251560
Radial M12 Connector	4-pole, grey, P.V.C.	3 m	CS-A2-02-G-03	95A251360
		5 m	CS-A2-02-G-05	95A251240
		7 m	CS-A2-02-G-07	95A251245
		10 m	CS-A2-02-G-10	95A251260
	4-pole, P.U.R.	2 m	CS-A2-02-R-02	95A251550
		5 m	CS-A2-02-R-05	95A251570
Axial M12 Connector	4-pole, shielded, black, P.V.C.	3 m	CV-A1-22-B-03	95ACC1480
		5 m	CV-A1-22-B-05	95ACC1490
		10 m	CV-A1-22-B-10	95ACC1500
		15 m	CV-A1-22-B-15	95ACC2070
		25 m	CV-A1-22-B-25	95ACC2090
Radial M12 Connector	4-pole, shielded, black, P.V.C.	3 m	CV-A2-22-B-03	95ACC1540
		5 m	CV-A2-22-B-05	95ACC1550
		10 m	CV-A2-22-B-10	95ACC1560
Axial M12 Connector	4-pole, U.L., black, P.V.C.	3 m	CS-A1-02-U-03	95ASE1120
		5 m	CS-A1-02-U-05	95ASE1130
		10 m	CS-A1-02-U-10	95ASE1140
		15 m	CS-A1-02-U-15	95ASE1150
		25 m	CS-A1-02-U-25	95ASE1160
Radial M12 Connector	4-pole, black	Connector- not cabled	CS-A1-02-B-NC	G5085002
		Connector- not cabled	CS-A2-02-B-NC	G5085003

TUBULAR SENSORS

S50/S51

Extended range of standard "One for All" photoelectric tubular M18 sensors

- All optic functions and LASER models
- M18 flat plastic with universal mounting
- Available in M18 metal housing
- Axial or radial optics, cable or connector
- Standard 4-wire NO-NC NPN or PNP output

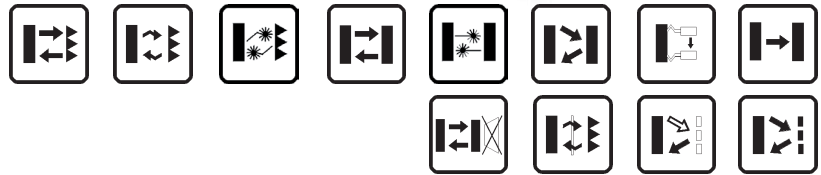

APPLICATIONS

- Processing and Packaging machinery
- Conveyor lines, material handling
- Ceramics intralogistics
- Automated warehousing



(*) Axial models.
ATEX II 3DG

S50/S51		
Through beam		0...20 m 0...60 m (class 1 LASER) (S50)
Retroreflective (on R2 reflector)		0,1...4 m
Polarized retroreflective		0,1...4 m (S50) 0,1...3 m (S51) 0,1...16 m (class 1 LASER) (S50)
Retroreflective for transparent (on R2 reflector)		0,1...1,3 m (S50)
Diffuse proximity		short distance 0...100 mm medium distance 0...400 mm (S50) 0...450 mm (S51) long distance 0...700 mm long distance LASER 0...350 mm
Fixed focus		100 mm (S50)
Background suppression		50...100 mm (S50)
Through beam with fiber optic		0...100 mm (S50)
Diffuse proximity with fiber optic		0...30 mm (S50)
Contrast sensor		10 ± 2 mm
Luminescence sensor		0...20 mm
Power supply	Vdc	10...30 V
	Vac	
	Vac/dc	
Output	PNP	▪
	NPN	▪
	NPN/PNP	
	relay	
	other	
Connection	cable	▪
	connector	▪
	pig-tail	
Approximate dimensions (mm)		M18x 55/68
Housing material		PBT, nickel plated brass
Mechanical protection		IP67

TECHNICAL DATA

Power supply	10 ... 30 Vdc (limit values)
Ripple	2 Vpp max.
Consumption (output current excluded)	35 mA max. (mod. S50...A00/B01/C01/C10/C21/D00/E01/T01) 30 mA max. (mod. S50...F01/M03, S51...A00/B01/C01/C10/C20/F00) 25 mA max. (mod. S50...W03/U03)
Light emission	red LED 630 nm (mod. S50...D00/E01, S50-PA/MA...M03) red LED 660 nm (mod. S50...B01/T01, S51...B01) red LED 670 nm (mod. S50-PS/MS...M03) IR LED 880 nm (mod. S50/51...A00/C01/C10/C20/C21/G00) white LED 400-700 nm (mod. S50...W03) UV LED 370 nm (mod. S50...U03) red Laser 650 nm (mod. S50...G00/F01/B01/C01)
Setting	sensitivity trimmer (mod. B01/C01/C21/E01/F01/T01) teach-in push-button (mod. M03/W03/U03)
Operating mode	LIGHT mode on N.O. output / DARK mode on N.C. output (mod. S50...C01/C10/C21/D00/M03/U03) DARK mode on N.O. output / LIGHT mode on N.C. output (mod. S50...A00/B01/E01/F01/T01/W03) white wire or pin 2 connected to +10...30V LIGHT mode/ to 0V DARK mode (mod. S51) white wire or pin 2 not connected LIGHT mode (mod. S51...C01/C10/C20) / DARK mode (mod. S51...A00/B01/F00)
Indicators	yellow OUTPUT LED (S50, S51, excl. mod. G00) green STABILITY LED (mod. S50...B01/C01/C21/E01/F01), POWER LED (mod. S50...G00, S51) green/red READY/ERROR LED (mod. S50...M03/W03/U03)
Output	PNP or NPN; NO; NC (mod. S50)
Output current	100 mA max.
Saturation voltage	2 V max.
Response time	0,5 ms (mod. S50...A00/B01/T01/C10/C21/C01/D00/E01/U03) 2 ms (mod. S50...F01/G00) 1 ms (mod. S50...M03, S51...A00/B01/C01/C10/G00) 4 ms (mod. S51...F00) 100 µs (mod. S50...W03) 333 µs (Laser mod. S50)
Switching frequency	1 kHz (mod. S50...A00/B01/T01/C10/C21/C01/D00/E01/U03) 250 Hz (mod. S50...F01/G00) 500 Hz (mod. S50...M03, S51...A00/B01/C01/C10/G00) 120 Hz (mod. S51...F00) 5 kHz (mod. S50...W03) 1,5 kHz (Laser mod. S50)
Connection	2 m cable Ø 4 mm, M12 4-pole connector
Dielectric strength	500 Vac, 1 min between electronics and housing
Insulating resistance	>20 MΩ, 500 Vdc between electronics and housing
Electrical protection	class 2
Mechanical protection	IP67
Ambient light rejection	according to EN 60947-5-2
Vibrations	0,5 mm amplitude, 10 ... 55 Hz frequency, for every axis (EN60068-2-6)
Shock resistance	11 ms (30 G) 6 shock for every axis (EN60068-2-27)
Housing material	Plastic version PBT Metal version nickel plated brass
Lens material	PMMA
Operating temperature	-25 ... 55 °C (Laser mod.) -10 ... 50 °C
Storage temperature	-25 ... 70 °C
Weight	Plastic version 75 g max. cable vers. (90 g max. mod. M03), 25 g max. conn. vers. (40 g max. mod. M03) Metal version 110 g max. cable vers. (125 g max. mod. M03), 60 g max. conn. vers. (75 g max. mod. M03)

TUBULAR SENSORS

S50

DIMENSIONS

PLASTIC

AXIAL VERSION

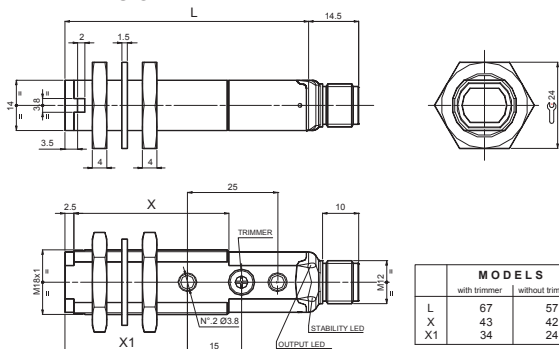

RADIAL VERSION

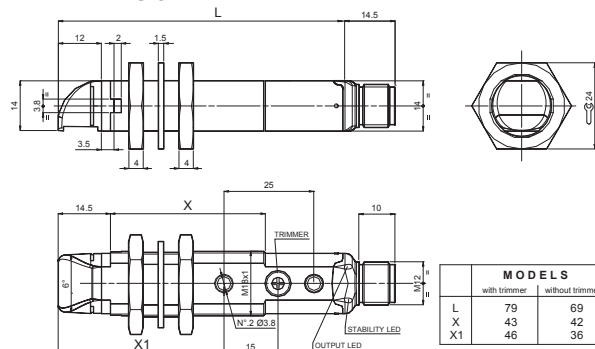

FIBRE OPTIC VERSION

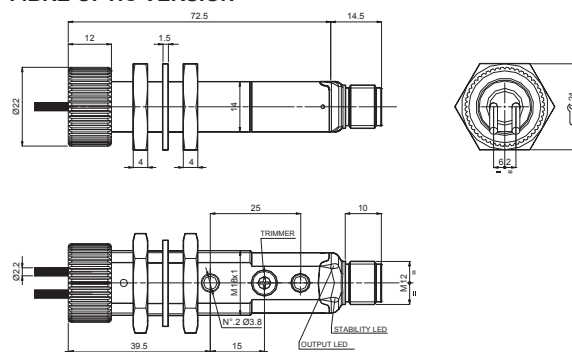

METAL

AXIAL VERSION

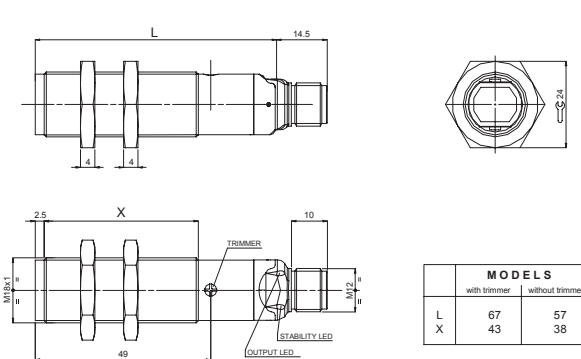

RADIAL VERSION

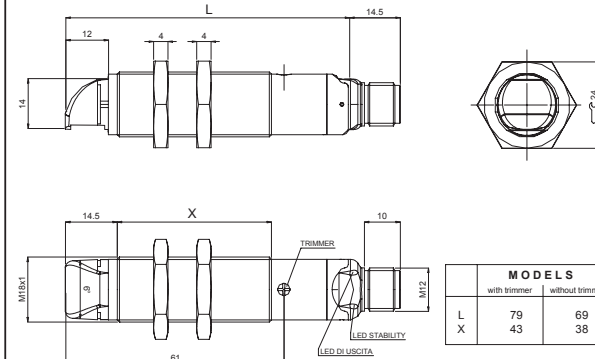

FIBRE OPTIC VERSION

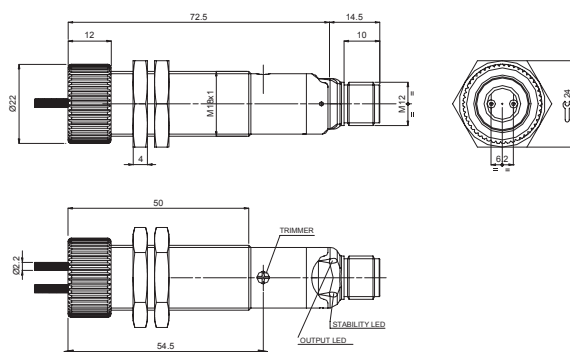

BACKGROUND SUPPRESSION AXIAL VERSION

PLASTIC

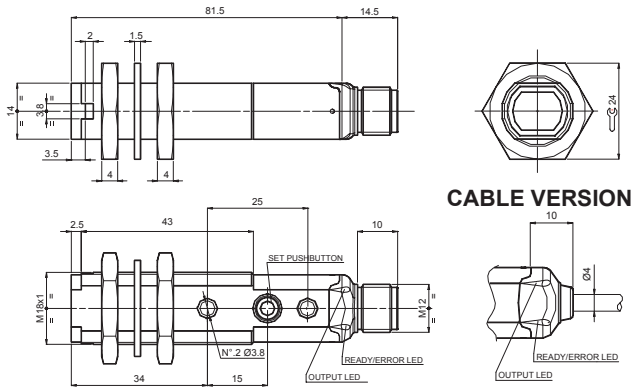

METAL

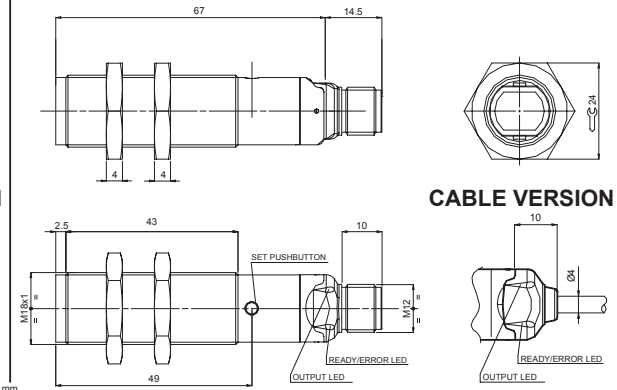

BACKGROUND SUPPRESSION RADIAL VERSION

PLASTIC

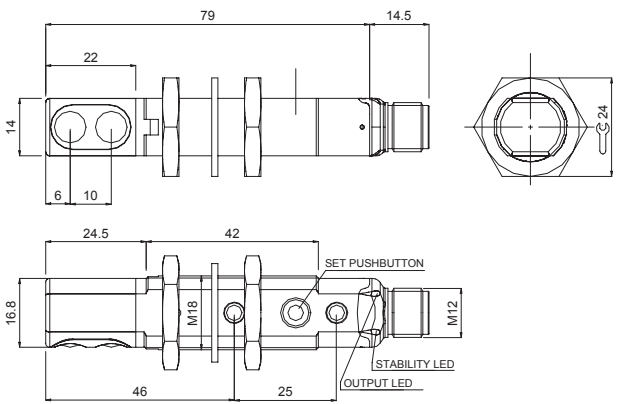

METAL

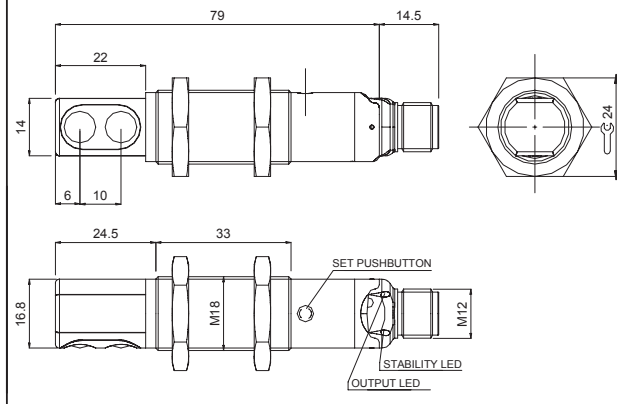

LUMINESCENCE AND CONTRAST

PLASTIC

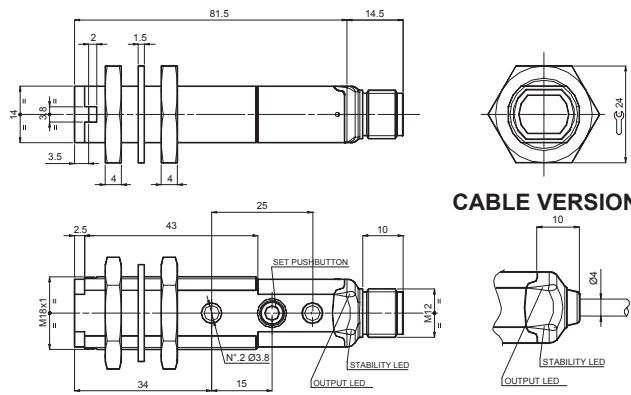

METAL

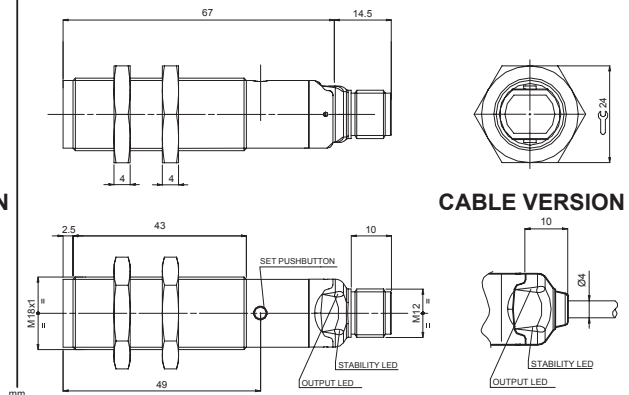

CONNECTIONS

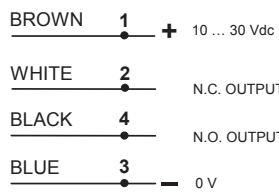

CABLE

Through beam emitter

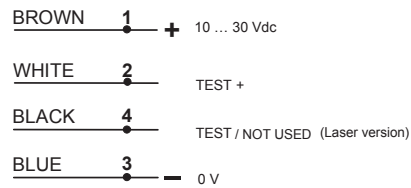

M12 CONNECTOR

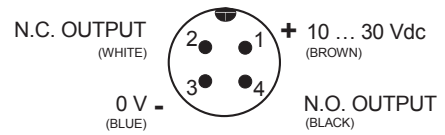

TUBULAR SENSORS

S51

DIMENSIONS

PLASTIC

AXIAL VERSION

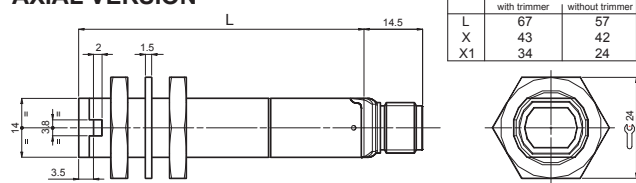

	MODELS	
	with trimmer	without trimmer
L	67	57
X	43	42
X1	34	24

RADIAL VERSION

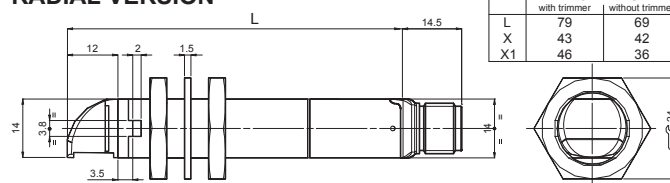

	MODELS	
	with trimmer	without trimmer
L	79	69
X	43	42
X1	46	36

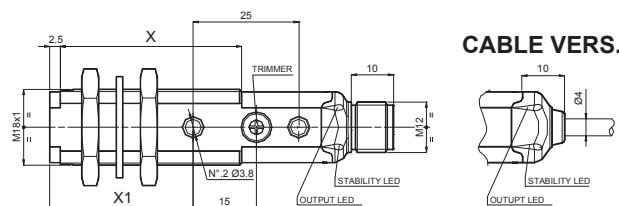

CABLE VERS.

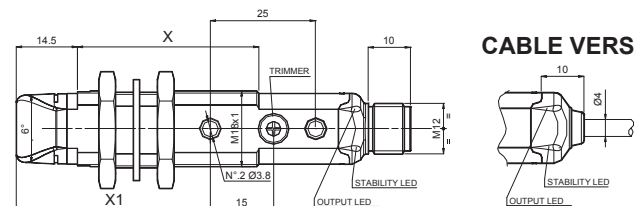

CABLE VERS.

CH.24 PLASTIC NUTS

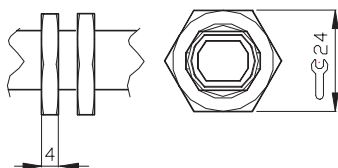

CH.22 PLASTIC NUTS

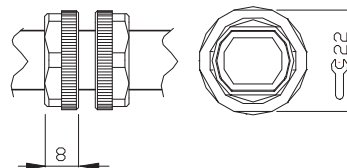

METAL

AXIAL VERSION

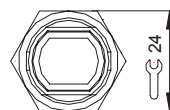
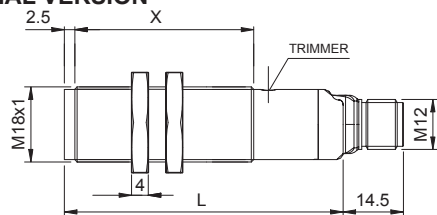

	MODELS	
	B01/C01/F00	A00/C10/G00
L	67	57
X	43	38

RADIAL VERSION

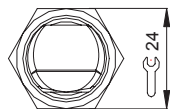
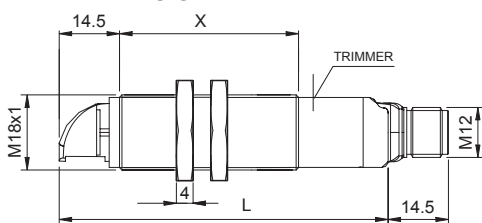

	MODELS	
	B01/C01/F00	A00/C10/G00
L	79	69
X	43	38

CABLE VERSION

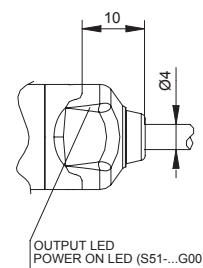

CONNECTIONS

CABLE

BROWN	1	+	10 ... 30 Vdc
WHITE	2		DARK- / LIGHT+
BLACK	4		N.O. OUTPUT
BLUE	3	-	0 V

Through beam emitter

BROWN	1	+	10 ... 30 Vdc
WHITE	2		TEST +
BLACK	4		TEST -
BLUE	3	-	0 V

M12 CONNECTOR

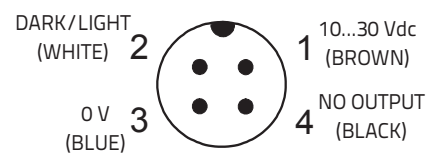

S50/S51

INDICATORS AND SETTINGS

S50-XX...A00/B01/C01/C21/E01/F01/T01

S51-XX...B01/C01



- A** OUTPUT status LED Yellow
STABILITY LED Green (Only Receiver)
POWER ON LED Green (Only Emitter)

- B** Adjustment trimmer (receiver)

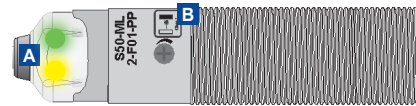

Single-turn trimmer for sensitivity adjustment. Rotate in a clockwise direction to increase the operating distance.

S50-XX-M03/W03/U03

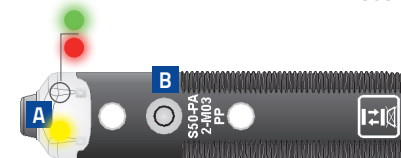

- A** OUTPUT status LED Yellow
READY LED Green
ERROR LED Red

- B** Teach-in push-button

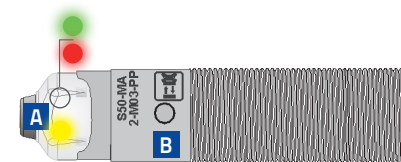

Teach-in button for setting. EASYtouch™ provides two setting modes: standard or fine, both obtained by pressing the push-button only once. Please refer to instructions manual for operating details.

S50-XX-C10

S51-XX-A00/C10/C20/F00/G00



- A** A00/C10/C20/F00
OUTPUT status LED Yellow
STABILITY LED green

- G00
OUTPUT status LED yellow (Only Emitter G00)

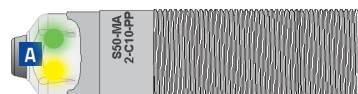

TUBULAR SENSORS

S50 DETECTION DIAGRAMS

G/F INFRARED EMISSION

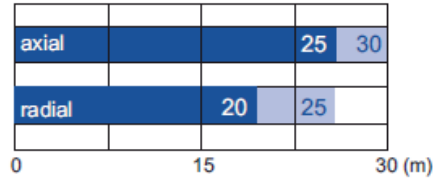

■ Recommended operating distance
 ■ Maximum operating distance

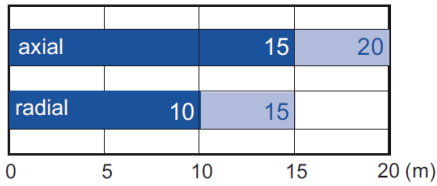
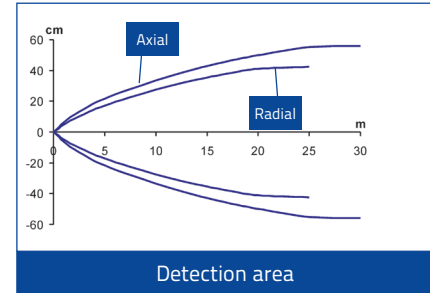
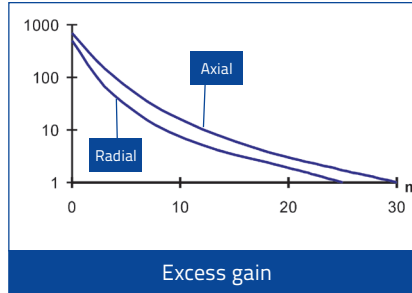

■ Recommended operating distance
 ■ Maximum operating distance

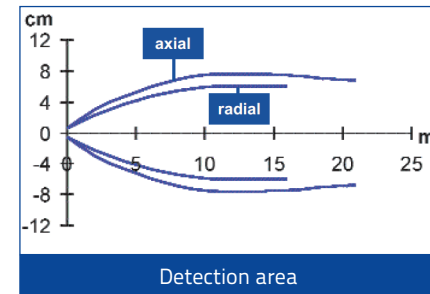
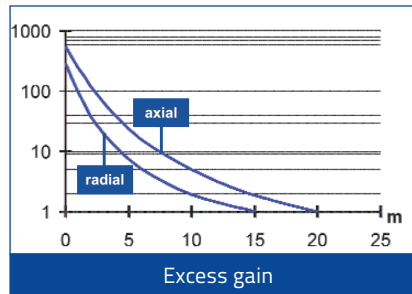

G/F LASER RED EMISSION



■ Operating distance

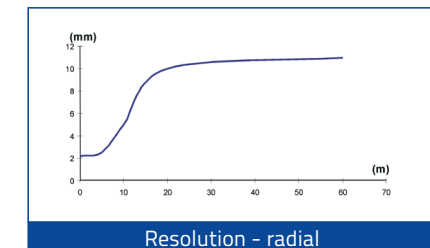
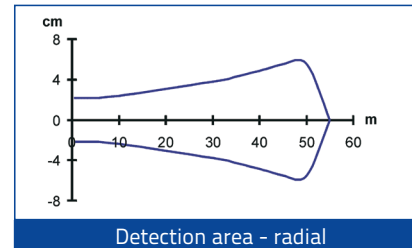
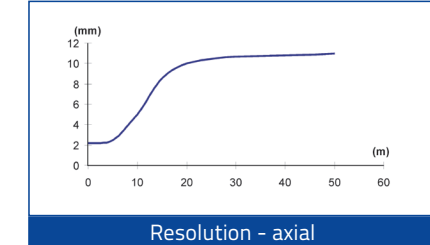
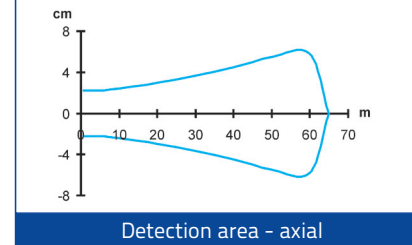

■ Operating distance

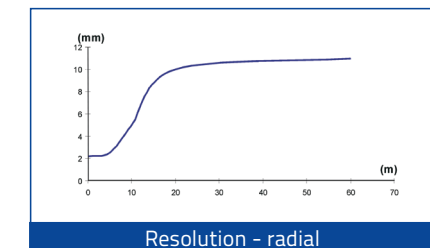
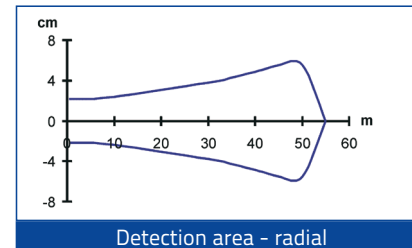
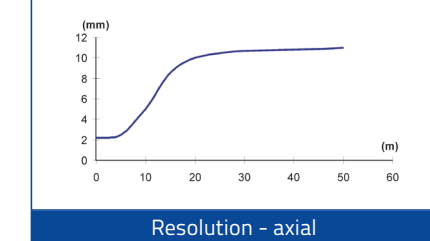
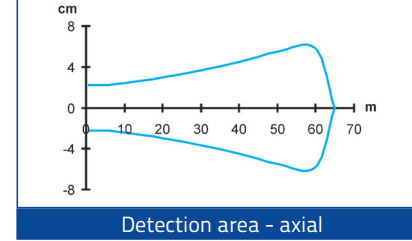

A INFRARED EMISSION

axial on R2	4
axial on R5	5

0.1 1 2 3 4 5 (m)

■ Operating distance

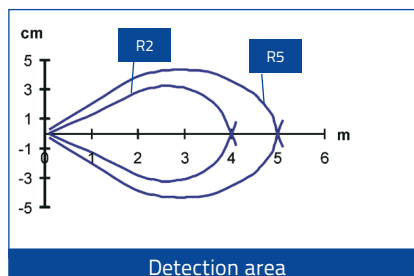
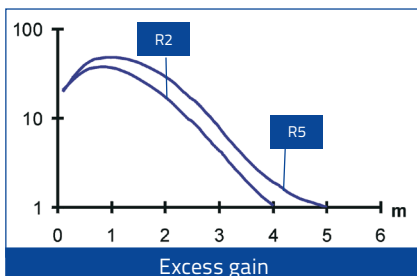

B RED EMISSION

axial on R5	4	4.5
axial on R2	3.5	4
radial on R5	2.5	3
radial on R2	2	2.5

0.1 1 2 3 4 5 (m)

■ Recommended operating distance
 ■ Maximum operating distance

High efficiency reflectors can be used to obtain larger operating distances. Refer to **Reflectors (A.01)**.

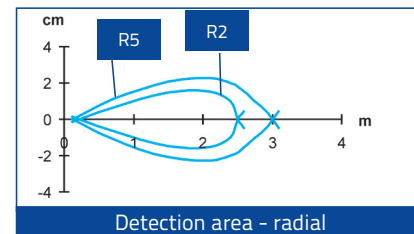
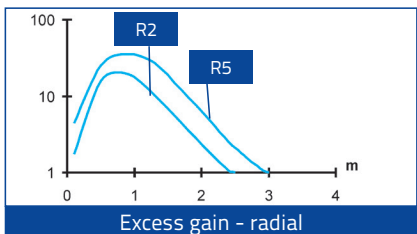
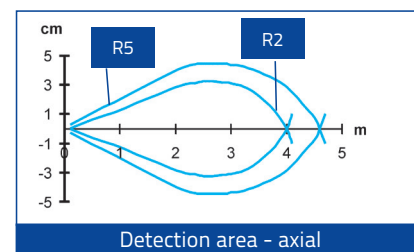
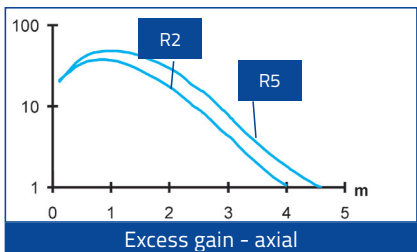

B LASER RED EMISSION

axial on R2	16
axial on R7	11
radial on R2	9
radial on R7	6

8 12 16 (m)

■ Operating distance

High efficiency reflectors can be used to obtain larger operating distances. Refer to **Reflectors (A.01)**.

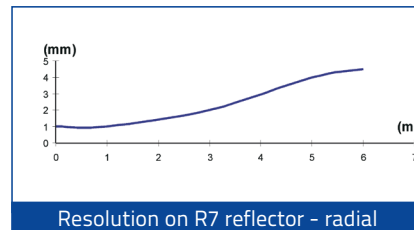
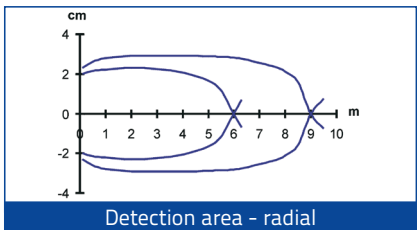
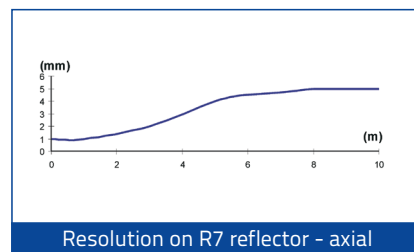
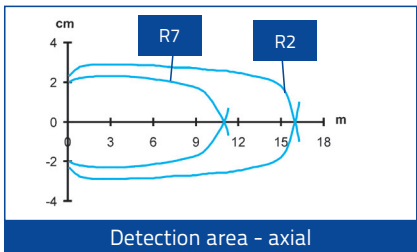

T RED EMISSION

axial on R5	1.4	1.7
axial on R2	1	1.3
radial on R5	1.4	1.7
radial on R2	1	1.3

0.1 0.5 1 1.5 2 (m)

■ Recommended operating distance
 ■ Maximum operating distance

High efficiency reflectors can be used to obtain larger operating distances. Refer to **Reflectors**.

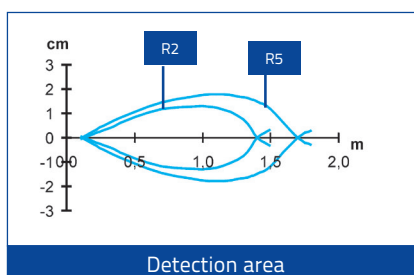
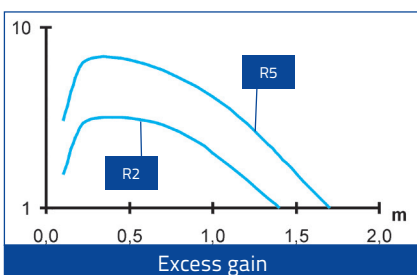

TUBULAR SENSORS

C SHORT INFRARED EMISSION

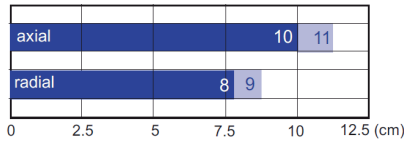

■ Recommended operating distance
 ■ Maximum operating distance

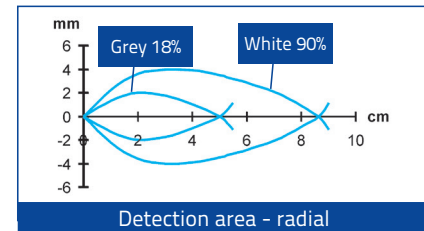
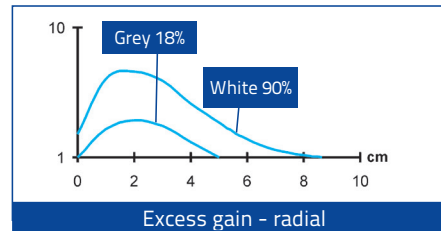
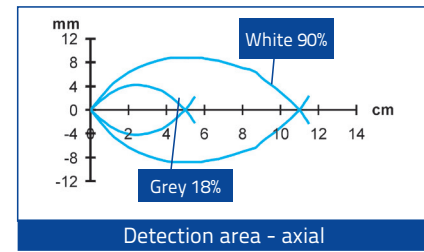
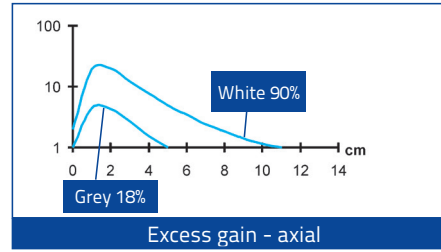

C MID INFRARED EMISSION

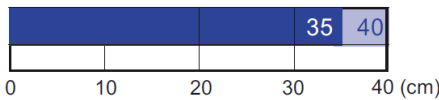

■ Recommended operating distance
 ■ Maximum operating distance

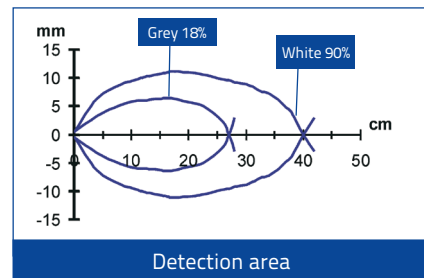
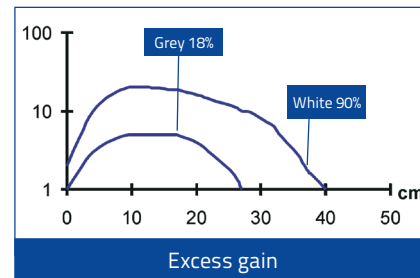

C LONG INFRARED EMISSION

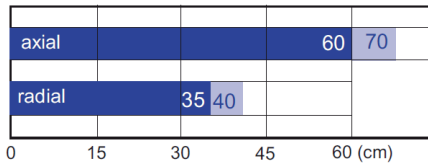

■ Recommended operating distance
 ■ Maximum operating distance

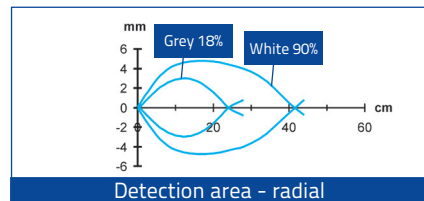
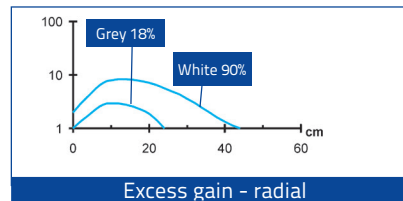
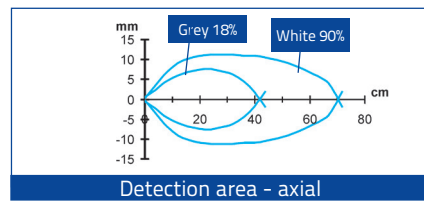
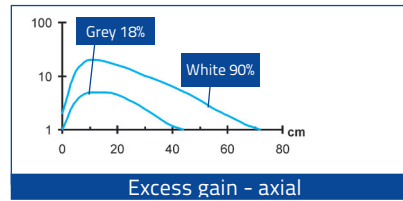

D RED EMISSION

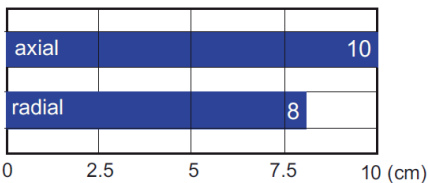

■ Operating distance

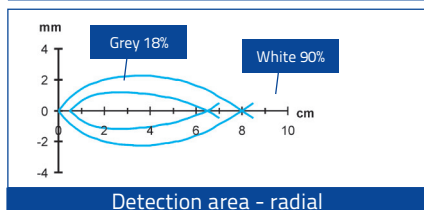
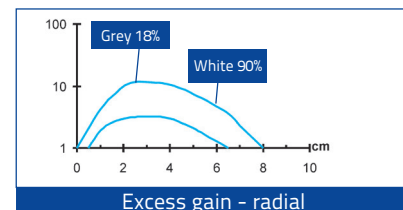
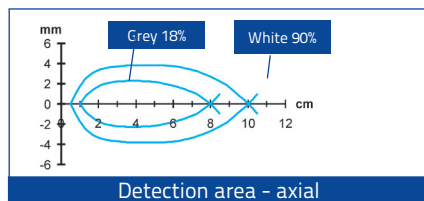
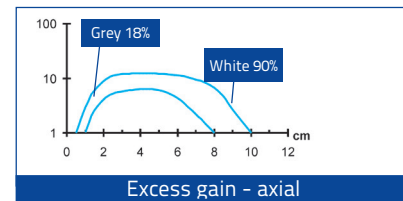

C LASER RED EMISSION

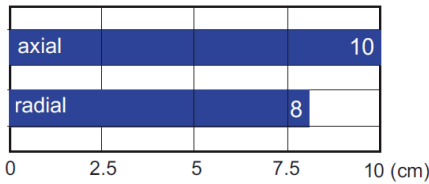

Operating distance

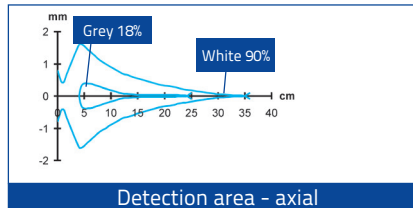

Detection area - axial

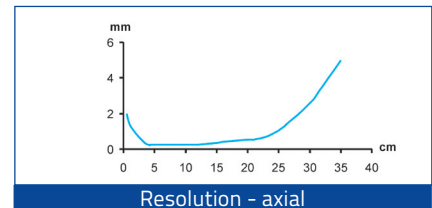

Resolution - axial

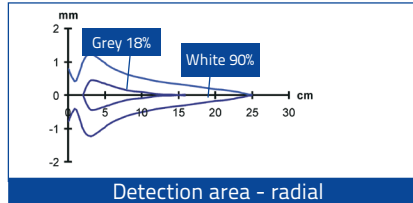

Detection area - radial

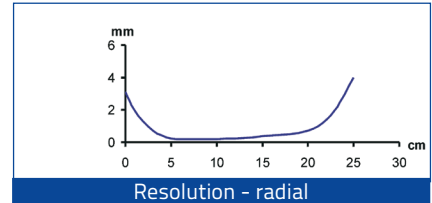

Resolution - radial

M AXIAL RED EMISSION

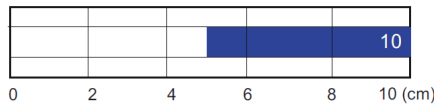

Operating distance

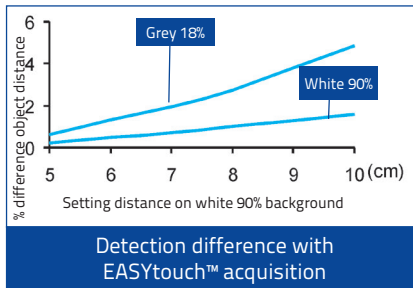

Detection difference with EASYtouch™ acquisition

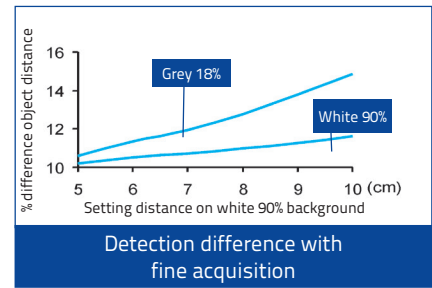

Detection difference with fine acquisition

M RADIAL RED EMISSION

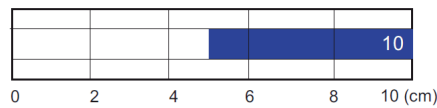

Operating distance

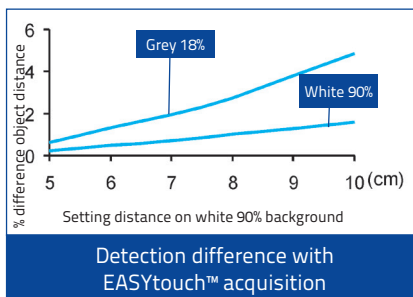

Detection difference with EASYtouch™ acquisition

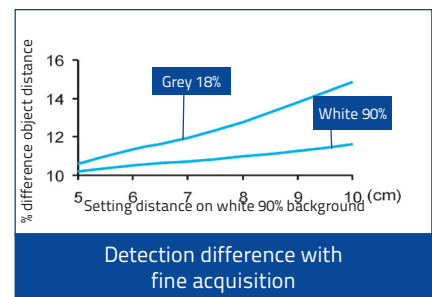

Detection difference with fine acquisition

E RED EMISSION

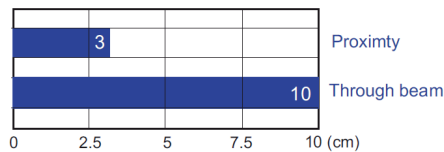

Operating distance with standard fibers

Standard Fiber-optics:
OF-42-ST-20 proximity
OF-43-ST-20 through beam

High efficiency fiber-optics or accessory lenses can be used to obtain larger operating distances.

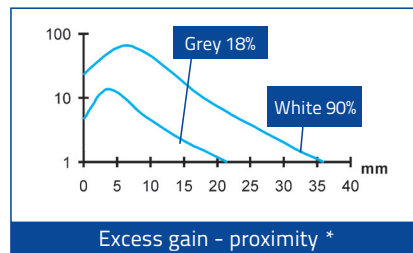

Excess gain - proximity *

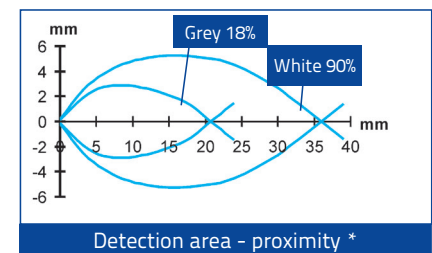

Detection area - proximity *

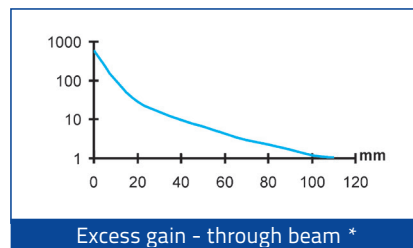

Excess gain - through beam *

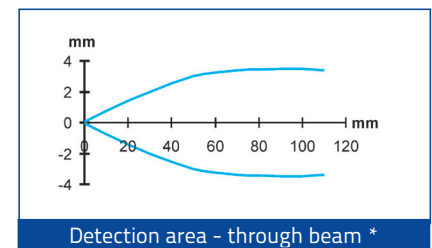

Detection area - through beam *

* standard Fiber-optics

TUBULAR SENSORS

W WHITE EMISSION

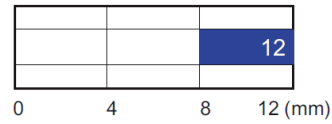

Operating distance

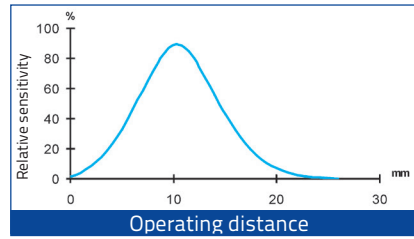

U UV EMISSION

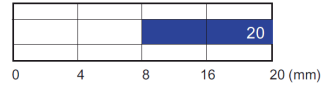

Operating distance

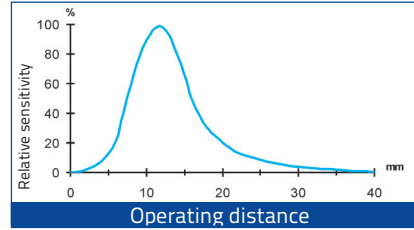

S51 DETECTION DIAGRAMS

M18 STANDARD

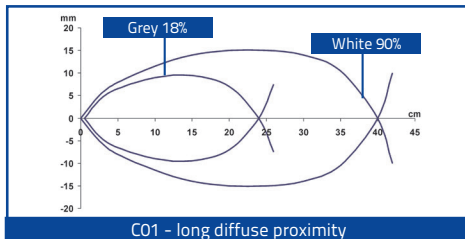

C01 - long diffuse proximity

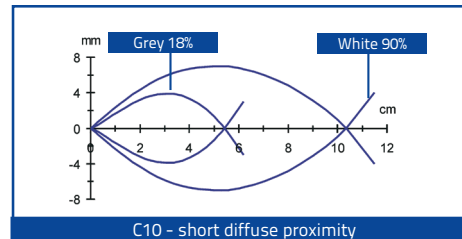

C10 - short diffuse proximity

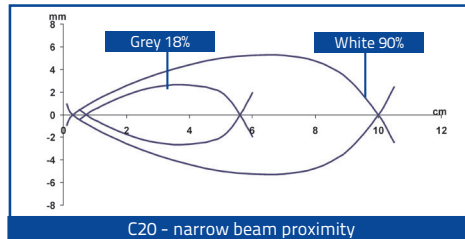

C20 - narrow beam proximity

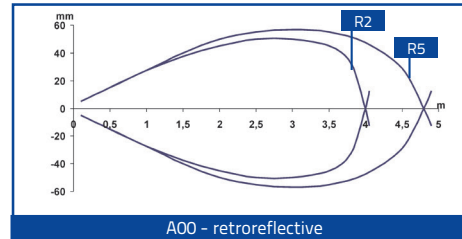

A00 - retroreflective

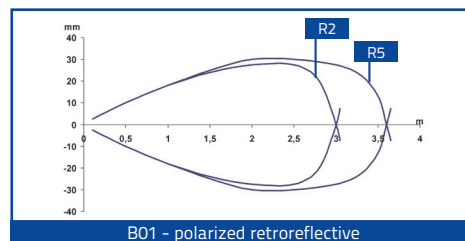

B01 - polarized retroreflective

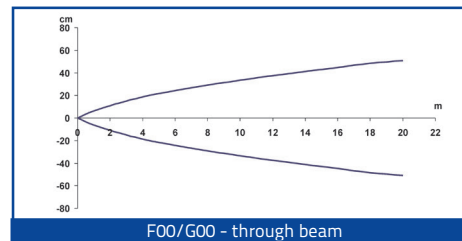

F00/G00 - through beam

Note: the diagrams indicate the detection area typical of the axial optic versions; the maximum operating distance of the radial optic versions decreases as indicated in the tables given below

A00	3,5	4
Axial on R2		
A00	4	4,5
Axial on R5		
A00	2,5	3
Radial on R2		
A00	3	3,5
Radial on R5		

B01	2,5	3
Axial on R2		
B01	3	3,5
Axial on R5		
B01	2	2,5
Radial on R2		
B01	2,5	3
Radial on R5		

F/G	18	20
Axial		
F/G	15	18
Radial		

C01	40	45
Axial		
C01	30	35
Radial		

C10/C20	10
Axial	
C10	8
Radial	

Recommended operating distance
Maximum operating distance

MODEL SELECTION AND ORDER INFORMATION

S50 PLASTIC MODELS					
OPTIC FUNCTION	EMISSION	CONNECTION	OUTPUT	MODEL	ORDER No.
Retroreflective	LED, Axial optic	2m Cable	NPN	S50-PA-2-A00-NN	952002090
			PNP	S50-PA-2-A00-PP	952002080
		M12 Connector	NPN	S50-PA-5-A00-NN	952002110
			PNP	S50-PA-5-A00-PP	952002100
Polarized retroreflective	LED, Axial optic	2m Cable	NPN	S50-PA-2-B01-NN	952001610
			PNP	S50-PA-2-B01-PP	952001010
		M12 Connector	NPN	S50-PA-5-B01-NN	952001500
			PNP	S50-PA-5-B01-PP	952001020
	LED, Radial optic	2m Cable	NPN	S50-PR-2-B01-NN	952001780
			PNP	S50-PR-2-B01-PP	952001030
		M12 Connector	NPN	S50-PR-5-B01-NN	952001720
			PNP	S50-PR-5-B01-PP	952001040
	LASER, Axial optic	2m Cable	NPN	S50-PL-2-B01-NN	952001870
			PNP	S50-PL-2-B01-PP	952001360
		M12 Connector	NPN	S50-PL-5-B01-NN	952001840
			PNP	S50-PL-5-B01-PP	952001370
LASER, Radial optic	2m Cable	NPN	S50-PH-2-B01-NN	952001950	
		PNP	S50-PH-2-B01-PP	952001940	
	M12 Connector	NPN	S50-PH-5-B01-NN	952001970	
		PNP	S50-PH-5-B01-PP	952001960	
Long Diffuse proximity	LED, Axial optic	2m Cable	NPN	S50-PA-2-C01-NN	952001620
			PNP	S50-PA-2-C01-PP	952001050
		M12 Connector	NPN	S50-PA-5-C01-NN	952001510
			PNP	S50-PA-5-C01-PP	952001060
	LED, Radial optic	2m Cable	NPN	S50-PR-2-C01-NN	952001790
			PNP	S50-PR-2-C01-PP	952001070
		M12 Connector	NPN	S50-PR-5-C01-NN	952001730
			PNP	S50-PR-5-C01-PP	952001080
	LASER, Axial optic	2m Cable	NPN	S50-PL-2-C01-NN	952001880
			PNP	S50-PL-2-C01-PP	952001380
		M12 Connector	NPN	S50-PL-5-C01-NN	952001850
			PNP	S50-PL-5-C01-PP	952001390
LASER, Radial optic	2m Cable	NPN	S50-PH-2-C01-NN	952001990	
		PNP	S50-PH-2-C01-PP	952001980	
	M12 Connector	NPN	S50-PH-5-C01-NN	952002010	
		PNP	S50-PH-5-C01-PP	952002000	
Short Diffuse proximity	LED, Axial optic	2m Cable	NPN	S50-PA-2-C10-NN	952001630
			PNP	S50-PA-2-C10-PP	952001240
		M12 Connector	NPN	S50-PA-5-C10-NN	952001520
	LED, Radial optic	2m Cable	NPN	S50-PR-2-C10-NN	952001800
			PNP	S50-PR-2-C10-PP	952001490
		M12 Connector	NPN	S50-PR-5-C10-NN	952001740
PNP	S50-PR-5-C10-PP	952001480			
	Medium Diffuse proximity	2m Cable	NPN	S50-PA-2-C21-NN	952002170
			PNP	S50-PA-2-C21-PP	952002160
M12 Connector		NPN	S50-PA-5-C21-NN	952002190	
		PNP	S50-PA-5-C21-PP	952002180	
Fixed focus	LED, Axial optic	2m Cable	NPN	S50-PA-2-D00-NN	952001640
			PNP	S50-PA-2-D00-PP	952001090
		M12 Connector	NPN	S50-PA-5-D00-NN	952001530
	LED, Radial optic	2m Cable	NPN	S50-PR-2-D00-NN	952001810
			PNP	S50-PR-2-D00-PP	952001110
		M12 Connector	NPN	S50-PR-5-D00-NN	952001750
PNP	S50-PR-5-D00-PP	952001120			
Fiber optic	LED, Axial optic	2m Cable	NPN	S50-PA-2-E01-NN	952001650
			PNP	S50-PA-2-E01-PP	952001130
		M12 Connector	NPN	S50-PA-5-E01-NN	952001540
			PNP	S50-PA-5-E01-PP	952001140

TUBULAR SENSORS

OPTIC FUNCTION	EMISSION	CONNECTION	OUTPUT	MODEL	ORDER No.
Through beam receiver	LED, Axial optic	2m Cable	NPN	S50-PA-2-F01-NN	952001660
			PNP	S50-PA-2-F01-PP	952001150
		M12 Connector	NPN	S50-PA-5-F01-NN	952001550
			PNP	S50-PA-5-F01-PP	952001160
	LED, Radial optic	2m Cable	NPN	S50-PR-2-F01-NN	952001820
			PNP	S50-PR-2-F01-PP	952001170
		M12 Connector	NPN	S50-PR-5-F01-NN	952001760
			PNP	S50-PR-5-F01-PP	952001180
	LASER, Axial optic	2m Cable	NPN	S50-PL-2-F01-NN	952001890
			PNP	S50-PL-2-F01-PP	952001400
		M12 Connector	NPN	S50-PL-5-F01-NN	952001860
			PNP	S50-PL-5-F01-PP	952001410
LASER, Radial optic	2m Cable	NPN	S50-PH-2-F01-NN	952002030	
		PNP	S50-PH-2-F01-PP	952002020	
	M12 Connector	NPN	S50-PH-5-F01-NN	952002050	
		PNP	S50-PH-5-F01-PP	952002040	
Through beam emitter	LED, Axial optic	2m Cable	-	S50-PA-2-G00-XG	952001190
		M12 Connector	-	S50-PA-5-G00-XG	952001200
	LED, Radial optic	2m Cable	-	S50-PR-2-G00-XG	952001210
		M12 Connector	-	S50-PR-5-G00-XG	952001220
	LASER, Axial optic	2m Cable	-	S50-PL-2-G00-XG	952001420
		M12 Connector	-	S50-PL-5-G00-XG	952001430
	LASER, Radial optic	2m Cable	-	S50-PH-2-G00-XG	952002060
		M12 Connector	-	S50-PH-5-G00-XG	952002070
Background suppression	LED, Axial optic	2m Cable	NPN	S50-PA-2-M03-NN	952001670
			PNP	S50-PA-2-M03-PP	952001230
		M12 Connector	NPN	S50-PA-5-M03-NN	952001560
			PNP	S50-PA-5-M03-PP	952001000
	LED, Radial optic	2m Cable	NPN	S50-PS-2-M03-NN	952001900
			PNP	S50-PS-2-M03-PP	952001910
		M12 Connector	NPN	S50-PS-5-M03-NN	952001920
			PNP	S50-PS-5-M03-PP	952001930
Retroreflective for transparent	LED, Axial optic	2m Cable	NPN	S50-PA-2-T01-NN	952001690
			PNP	S50-PA-2-T01-PP	952001260
		M12 Connector	NPN	S50-PA-5-T01-NN	952001580
			PNP	S50-PA-5-T01-PP	952001270
	LED, Radial optic	2m Cable	NPN	S50-PR-2-T01-NN	952001830
			PNP	S50-PR-2-T01-PP	952001280
		M12 Connector	NPN	S50-PR-5-T01-NN	952001770
			PNP	S50-PR-5-T01-PP	952001290
Luminescence	LED, Axial optic	2m Cable	NPN	S50-PA-2-U03-NN	952001700
			PNP	S50-PA-2-U03-PP	952001300
		M12 Connector	NPN	S50-PA-5-U03-NN	952001590
			PNP	S50-PA-5-U03-PP	952001310
Contrast	LED, Axial optic	2m Cable	NPN	S50-PA-2-W03-NN	952001710
			PNP	S50-PA-2-W03-PP	952001320
		M12 Connector	NPN	S50-PA-5-W03-NN	952001600
			PNP	S50-PA-5-W03-PP	952001330



S50 METAL MODELS

OPTIC FUNCTION	EMISSION	CONNECTION	OUTPUT	MODEL	ORDER No.
Retroreflective	LED, Axial optic	2m Cable	NPN	S50-MA-2-A00-NN	952022090
			PNP	S50-MA-2-A00-PP	952022080
		M12 Connector	NPN	S50-MA-5-A00-NN	952022110
			PNP	S50-MA-5-A00-PP	952022100
Polarized retroreflective	LED, Axial optic	2m Cable	NPN	S50-MA-2-B01-NN	952021500
			PNP	S50-MA-2-B01-PP	952021000
		M12 Connector	NPN	S50-MA-5-B01-NN	952021660
			PNP	S50-MA-5-B01-PP	952021200
	LED, Radial optic	2m Cable	NPN	S50-MR-2-B01-NN	952021600
			PNP	S50-MR-2-B01-PP	952021140
		M12 Connector	NPN	S50-MR-5-B01-NN	952021760
			PNP	S50-MR-5-B01-PP	952021340
	LASER, Axial optic	2m Cable	NPN	S50-ML-2-B01-NN	952021820
			PNP	S50-ML-2-B01-PP	952021400
		M12 Connector	NPN	S50-ML-5-B01-NN	952021850
			PNP	S50-ML-5-B01-PP	952021440
	LASER, Radial optic	2m Cable	NPN	S50-MH-2-B01-NN	952021950
			PNP	S50-MH-2-B01-PP	952021940
		M12 Connector	NPN	S50-MH-5-B01-NN	952021970
			PNP	S50-MH-5-B01-PP	952021960
Long Diffuse proximity	LED, Axial optic	2m Cable	NPN	S50-MA-2-C01-NN	952021510
			PNP	S50-MA-2-C01-PP	952021010
		M12 Connector	NPN	S50-MA-5-C01-NN	952021670
			PNP	S50-MA-5-C01-PP	952021210
	LED, Radial optic	2m Cable	NPN	S50-MR-2-C01-NN	952021610
			PNP	S50-MR-2-C01-PP	952021150
		M12 Connector	NPN	S50-MR-5-C01-NN	952021770
			PNP	S50-MR-5-C01-PP	952021350
	LASER, Axial optic	2m Cable	NPN	S50-ML-2-C01-NN	952021830
			PNP	S50-ML-2-C01-PP	952021410
		M12 Connector	NPN	S50-ML-5-C01-NN	952021860
			PNP	S50-ML-5-C01-PP	952021450
	LASER, Radial optic	2m Cable	NPN	S50-MH-2-C01-NN	952021990
			PNP	S50-MH-2-C01-PP	952021980
		M12 Connector	NPN	S50-MH-5-C01-NN	952022010
			PNP	S50-MH-5-C01-PP	952022000
Short Diffuse proximity	LED, Axial optic	2m Cable	NPN	S50-MA-2-C10-NN	952021520
			PNP	S50-MA-2-C10-PP	952021020
		M12 Connector	NPN	S50-MA-5-C10-NN	952021680
	LED, Radial optic	2m Cable	NPN	S50-MR-2-C10-NN	952021620
			PNP	S50-MR-2-C10-PP	952021490
		M12 Connector	NPN	S50-MR-5-C10-NN	952021780
Medium Diffuse proximity	LED, Axial optic	2m Cable	NPN	S50-MA-2-C21-NN	952022130
			PNP	S50-MA-2-C21-PP	952022120
		M12 Connector	NPN	S50-MA-5-C21-NN	952022150
			PNP	S50-MA-5-C21-PP	952022140
Fixed focus	LED, Axial optic	2m Cable	NPN	S50-MA-2-D00-NN	952021530
			PNP	S50-MA-2-D00-PP	952021030
		M12 Connector	NPN	S50-MA-5-D00-NN	952021690
			PNP	S50-MA-5-D00-PP	952021230
	LED, Radial optic	2m Cable	NPN	S50-MR-2-D00-NN	952021630
			PNP	S50-MR-2-D00-PP	952021160
		M12 Connector	NPN	S50-MR-5-D00-NN	952021790
			PNP	S50-MR-5-D00-PP	952021360

TUBULAR SENSORS

OPTIC FUNCTION	EMISSION	CONNECTION	OUTPUT	MODEL	ORDER No.
Fiber optic	LED, Axial optic	2m Cable	NPN	S50-MA-2-E01-NN	952021880
			PNP	S50-MA-2-E01-PP	952021040
		M12 Connector	NPN	S50-MA-5-E01-NN	952021890
			PNP	S50-MA-5-E01-PP	952021240
Through beam receiver	LED, Axial optic	2m Cable	NPN	S50-MA-2-F01-NN	952021540
			PNP	S50-MA-2-F01-PP	952021050
		M12 Connector	NPN	S50-MA-5-F01-NN	952021700
			PNP	S50-MA-5-F01-PP	952021250
	LED, Radial optic	2m Cable	NPN	S50-MR-2-F01-NN	952021640
			PNP	S50-MR-2-F01-PP	952021170
		M12 Connector	NPN	S50-MR-5-F01-NN	952021800
			PNP	S50-MR-5-F01-PP	952021370
	LASER, Axial optic	2m Cable	NPN	S50-ML-2-F01-NN	952021840
			PNP	S50-ML-2-F01-PP	952021420
		M12 Connector	NPN	S50-ML-5-F01-NN	952021870
			PNP	S50-ML-5-F01-PP	952021460
	LASER, Radial optic	2m Cable	NPN	S50-MH-2-F01-NN	952022030
			PNP	S50-MH-2-F01-PP	952022020
		M12 Connector	NPN	S50-MH-5-F01-NN	952022050
			PNP	S50-MH-5-F01-PP	952022040
Through beam emitter	LED, Axial optic	2m Cable	-	S50-MA-2-G00-XG	952021060
		M12 Connector	-	S50-MA-5-G00-XG	952021260
	LED, Radial optic	2m Cable	-	S50-MR-2-G00-XG	952021180
		M12 Connector	-	S50-MR-5-G00-XG	952021380
	LASER, Axial optic	2m Cable	-	S50-ML-2-G00-XG	952021430
		M12 Connector	-	S50-ML-5-G00-XG	952021470
	LASER, Radial optic	2m Cable	-	S50-MH-2-G00-XG	952022060
		M12 Connector	-	S50-MH-5-G00-XG	952022070
Background suppression	LED, Axial optic	2m Cable	NPN	S50-MA-2-M03-NN	952021550
		M12 Connector	PNP	S50-MA-2-M03-PP	952021070
	LED, Radial optic	2m Cable	PNP	S50-MS-2-M03-PP	952021910
		M12 Connector	PNP	S50-MS-5-M03-PP	952021930
Retroreflective for transparent	LED, Axial optic	2m Cable	NPN	S50-MA-2-T01-NN	952021570
			PNP	S50-MA-2-T01-PP	952021090
		M12 Connector	NPN	S50-MA-5-T01-NN	952021730
			PNP	S50-MA-5-T01-PP	952021290
	LED, Radial optic	2m Cable	NPN	S50-MR-2-T01-NN	952021650
			PNP	S50-MR-2-T01-PP	952021190
		M12 Connector	NPN	S50-MR-5-T01-NN	952021810
			PNP	S50-MR-5-T01-PP	952021390
Luminescence	LED, Axial optic	M12 Connector	PNP	S50-MA-5-U03-PP	952021300
Contrast	LED, Axial optic	2m Cable	PNP	S50-MA-2-W03-PP	952021110
		M12 Connector	NPN	S50-MA-5-W03-NN	952021750
			PNP	S50-MA-5-W03-PP	952021310
S51 MODELS					
OPTIC FUNCTION	HOUSING/OPTIC	CONNECTION	OUTPUT	MODEL	ORDER No.
Retroreflective	Nickel Plated Brass, Axial	2m Cable	NPN	S51-MA-2-A00-NK	952701601
			PNP	S51-MA-2-A00-PK	952701541
		M12 Connector	NPN	S51-MA-5-A00-NK	952701801
			PNP	S51-MA-5-A00-PK	952701531
	Nickel Plated Brass, Radial	2m Cable	NPN	S51-MR-2-A00-NK	952701711
			PNP	S51-MR-2-A00-PK	952701651
		M12 Connector	NPN	S51-MR-5-A00-NK	952701911
			PNP	S51-MR-5-A00-PK	952701851
	Plastic, Axial	2m Cable	NPN	S51-PA-2-A00-NK	952701071
			PNP	S51-PA-2-A00-PK	952701001
		M12 Connector	NPN	S51-PA-5-A00-NK	952701331
			PNP	S51-PA-5-A00-PK	952701261
	Plastic, Radial	2m Cable	NPN	S51-PR-2-A00-NK	952701201
			PNP	S51-PR-2-A00-PK	952701131
		M12 Connector	NPN	S51-PR-5-A00-NK	952701461
			PNP	S51-PR-5-A00-PK	952701391

OPTIC FUNCTION	HOUSING/OPTIC	CONNECTION	OUTPUT	MODEL	ORDER No.	
Polarized retroreflective	Nickel Plated Brass, Axial	2m Cable	NPN	S51-MA-2-B01-NK	952701611	
			PNP	S51-MA-2-B01-PK	952701551	
		M12 Connector	NPN	S51-MA-5-B01-NK	952701811	
			PNP	S51-MA-5-B01-PK	952701761	
	Nickel Plated Brass, Radial	2m Cable	NPN	S51-MR-2-B01-NK	952701721	
			PNP	S51-MR-2-B01-PK	952701661	
		M12 Connector	NPN	S51-MR-5-B01-NK	952701921	
			PNP	S51-MR-5-B01-PK	952701861	
	Plastic, Axial	2m Cable	NPN	S51-PA-2-B01-NK	952701081	
			PNP	S51-PA-2-B01-PK	952701011	
		M12 Connector	NPN	S51-PA-5-B01-NK	952701341	
			PNP	S51-PA-5-B01-PK	952701271	
Plastic, Radial	2m Cable	NPN	S51-PR-2-B01-NK	952701211		
		PNP	S51-PR-2-B01-PK	952701141		
	M12 Connector	NPN	S51-PR-5-B01-NK	952701471		
		PNP	S51-PR-5-B01-PK	952701401		
Medium diffuse proximity	Nickel Plated Brass, Axial	2m Cable	NPN	S51-MA-2-C01-NK	952701621	
			PNP	S51-MA-2-C01-PK	952701561	
		M12 Connector	NPN	S51-MA-5-C01-NK	952701821	
			PNP	S51-MA-5-C01-PK	952701771	
	Nickel Plated Brass, Radial	2m Cable	NPN	S51-MR-2-C01-NK	952701731	
			PNP	S51-MR-2-C01-PK	952701671	
		M12 Connector	NPN	S51-MR-5-C01-NK	952701931	
			PNP	S51-MR-5-C01-PK	952701871	
	Plastic, Axial	2m Cable	NPN	S51-PA-2-C01-NK	952701091	
			PNP	S51-PA-2-C01-PK	952701021	
		M12 Connector	NPN	S51-PA-5-C01-NK	952701351	
			PNP	S51-PA-5-C01-PK	952701281	
	Plastic, Radial	2m Cable	NPN	S51-PR-2-C01-NK	952701221	
			PNP	S51-PR-2-C01-PK	952701151	
		M12 Connector	NPN	S51-PR-5-C01-NK	952701481	
			PNP	S51-PR-5-C01-PK	952701411	
	Short diffuse proximity	Nickel Plated Brass, Axial	2m Cable	NPN	S51-MA-2-C10-NK	952701631
				PNP	S51-MA-2-C10-PK	952701571
		M12 Connector	NPN	S51-MA-5-C10-NK	952701831	
			PNP	S51-MA-5-C10-PK	952701521	
Nickel Plated Brass, Radial		2m Cable	NPN	S51-MR-2-C10-NK	952701741	
			PNP	S51-MR-2-C10-PK	952701681	
		M12 Connector	NPN	S51-MR-5-C10-NK	952701941	
			PNP	S51-MR-5-C10-PK	952701881	
Plastic, Axial		2m Cable	NPN	S51-PA-2-C10-NK	952701101	
			PNP	S51-PA-2-C10-PK	952701031	
		M12 Connector	NPN	S51-PA-5-C10-NK	952701361	
			PNP	S51-PA-5-C10-PK	952701291	
Plastic, Radial		2m Cable	NPN	S51-PR-2-C10-NK	952701231	
			PNP	S51-PR-2-C10-PK	952701161	
		M12 Connector	NPN	S51-PR-5-C10-NK	952701491	
			PNP	S51-PR-5-C10-PK	952701421	
Narrow beam proximity		Nickel Plated Brass, Axial	M12 Connector	PNP	S51-MA-5-C20-PK	952701961
Through beam receiver		Nickel Plated Brass, Axial	2m Cable	NPN	S51-MA-2-F00-NK	952701641
			PNP	S51-MA-2-F00-PK	952701581	
		M12 Connector	NPN	S51-MA-5-F00-NK	952701841	
			PNP	S51-MA-5-F00-PK	952701781	
	Nickel Plated Brass, Radial	2m Cable	NPN	S51-MR-2-F00-NK	952701751	
			PNP	S51-MR-2-F00-PK	952701691	
		M12 Connector	NPN	S51-MR-5-F00-NK	952701951	
			PNP	S51-MR-5-F00-PK	952701891	
	Plastic, Axial	2m Cable	NPN	S51-PA-2-F00-NK	952701121	
			PNP	S51-PA-2-F00-PK	952701051	
		M12 Connector	NPN	S51-PA-5-F00-NK	952701381	
			PNP	S51-PA-5-F00-PK	952701311	
Plastic, Radial	2m Cable	NPN	S51-PR-2-F00-NK	952701251		
		PNP	S51-PR-2-F00-PK	952701181		
	M12 Connector	NPN	S51-PR-5-F00-NK	952701511		
		PNP	S51-PR-5-F00-PK	952701441		
Through beam emitter	Nickel Plated Brass, Axial	2m Cable	-	S51-MA-2-G00-XG	952701591	
		M12 Connector	-	S51-MA-5-G00-XG	952701791	
	Nickel Plated Brass, Radial	2m Cable	-	S51-MR-2-G00-XG	952701701	
		M12 Connector	-	S51-MR-5-G00-XG	952701901	
	Plastic, Axial	2m Cable	-	S51-PA-2-G00-XG	952701061	
		M12 Connector	-	S51-PA-5-G00-XG	952701321	
Plastic, Radial	2m Cable	-	S51-PR-2-G00-XG	952701191		
	M12 Connector	-	S51-PR-5-G00-XG	952701451		

TUBULAR SENSORS

S50/S51

ACCESSORIES

ST-5010

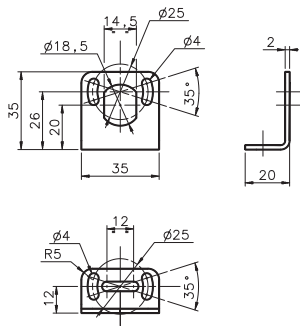

ST-5011

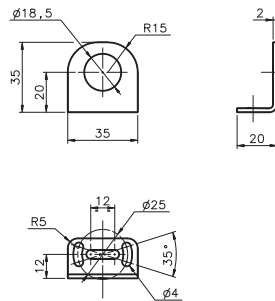

ST-5012

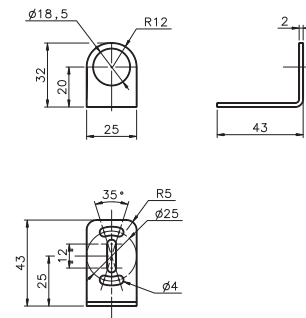

ST-5017

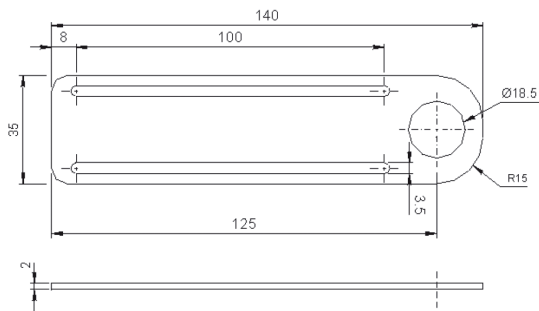

SWING-18

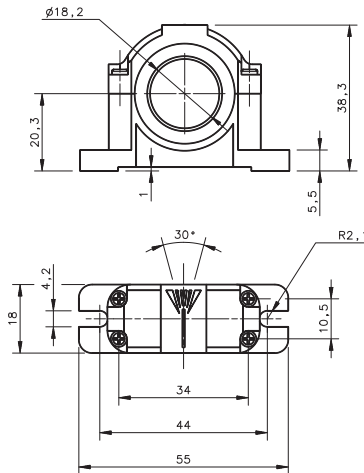

PLASTIC NUT

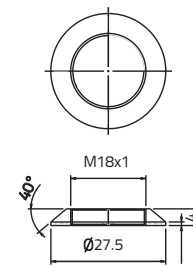

SP-40

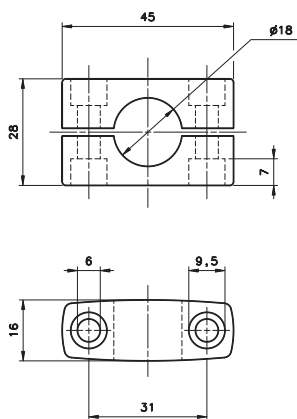

JOINT 18

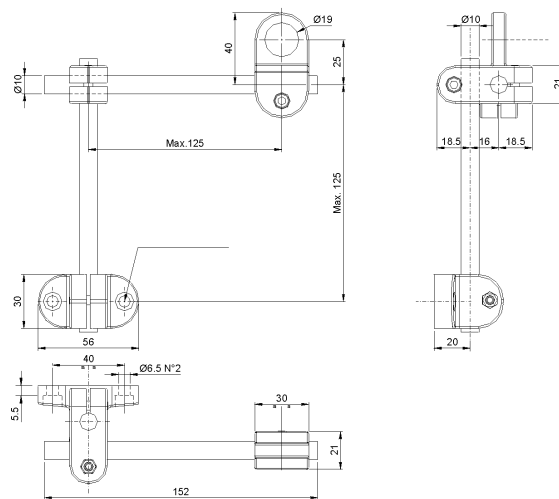

MICRO 18

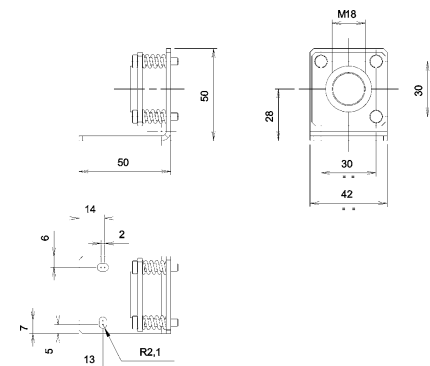

mm



MODEL	DESCRIPTION	ORDER No.
ST-5010	M18/14 mounting bracket	95ACC5230
ST-5011	M18 mounting bracket short	95ACC5240
ST-5012	M18 mounting bracket long	95ACC5250
ST-5017	M18 mounting bracket	95ACC5270
S50 EASY -IN	M18/14 EASY in™ adjustable mounting support	95ACC 5300
JOINT -18	M18 jointed support	95ACC 5220
MICRO -18	support with micrometric regulation for tubular M18 sensors	95ACC 1380
ST1218	M12/M18 mounting brackets	95ACC3340
ST1830	M18/M30 mounting brackets	95ACC3350
SP-40	mounting bracket tubular	95ACC1370
SWING-18	adjustable support for M18 tubular sensors	895000006
PLASTIC NUT	flared mounting nut	95ACC2630
MEK -PROOF	front protection (only for metal models)	G5000001

CABLES

TYPE	DESCRIPTION	LENGTH	MODEL	ORDER No.
Axial M12 Connector	4-pole, grey, P.V.C.	3 m	CS-A1-02-G-03	95A251380
		5 m	CS-A1-02-G-05	95A251270
		7 m	CS-A1-02-G-07	95A251280
		10 m	CS-A1-02-G-10	95A251390
	4-pole, P.U.R.	2 m	CS-A1-02-R-02	95A251540
		5 m	CS-A1-02-R-05	95A251560
Radial M12 Connector	4-pole, grey, P.V.C.	3 m	CS-A2-02-G-03	95A251360
		5 m	CS-A2-02-G-05	95A251240
		7 m	CS-A2-02-G-07	95A251245
		10 m	CS-A2-02-G-10	95A251260
	4-pole, P.U.R.	2 m	CS-A2-02-R-02	95A251550
		5 m	CS-A2-02-R-05	95A251570
Radial M12 Connector with LED (for PNP N.O. sensors)	4-pole, grey, P.V.C.	3 m	CS-A2-12-G-03	95A251400
		5 m	CS-A2-12-G-05	95A251350
		10 m	CS-A2-12-G-10	95A251370
Axial M12 Connector	4-pole, shielded, black, P.V.C.	3 m	CV-A1-22-B-03	95ACC1480
		5 m	CV-A1-22-B-05	95ACC1490
		10 m	CV-A1-22-B-10	95ACC1500
		15 m	CV-A1-22-B-15	95ACC2070
		25 m	CV-A1-22-B-25	95ACC2090
Radial M12 Connector	4-pole, shielded, black, P.V.C.	3 m	CV-A2-22-B-03	95ACC1540
		5 m	CV-A2-22-B-05	95ACC1550
		10 m	CV-A2-22-B-10	95ACC1560
Axial M12 Connector	4-pole, U.L., black, P.V.C.	3 m	CS-A1-02-U-03	95ASE1120
		5 m	CS-A1-02-U-05	95ASE1130
		10 m	CS-A1-02-U-10	95ASE1140
		15 m	CS-A1-02-U-15	95ASE1150
		25 m	CS-A1-02-U-25	95ASE1160
Radial M12 Connector	4-pole, black	Connector- not cabled	CS-A1-02-B-NC	G5085002
		Connector- not cabled	CS-A2-02-B-NC	G5085003

MINIATURE SENSORS

SMall

Complete line of amplified subminiature photoelectric sensors

- 15mm, 20mm, 30mm and 50mm fixed focus proximity
- 1,5m retroflective and 1m polarized retroflective
- 2m through beam models
- Amplified NPN or PNP output with NO-NC output



APPLICATIONS

- Processing and Packaging machinery
- Automotive
- Beverage & Bottling
- Vending machines

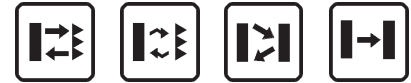

SM-all

Through beam		0...2 m
Retroreflective (on R2 reflector)		0,05...1,5 m
Polarized retroreflective		0,1...1 m
Fixed focus		3...15 mm
		3...20 mm
		3...30 mm
		3...50 mm
Power supply	Vdc	10...30 V
	Vac	
	Vac/dc	
Output	PNP	▪
	NPN	▪
	NPN/PNP	
	relay	
	other	
Connection	cable	▪
	connector	
	pig-tail	
Approximate dimensions (mm)		8x23x12
Housing material		Polycarbonate
Mechanical protection		IP67

TECHNICAL DATA

Power supply	10 ... 30 Vdc (limit values)
Ripple	10% max.
Consumption (output current excluded)	20 mA max.
Light emission	red LED 640 nm
Operating mode	LIGHT mode on N.O. output/DARK mode on N.C. output
Indicators	yellow OUTPUT LED excl. mod. G00 green POWER LED
Output	PNP or NPN; NO; NC
Output current	50 mA max.
Saturation voltage	1,25 V max. (NPN), 1,45 V max. (PNP)
Response time	700 µs 1,3 ms (mod. SM...F00/G00)
Switching frequency	700 Hz 385 Hz (mod. SM...F00/G00)
Connection	2 m cable Ø2,5 mm
Dielectric strength	500 Vac, 1 min between electronics and housing
Insulating resistance	>20 MΩ, 500 Vdc between electronics and housing
Electrical protection	class 2
Mechanical protection	IP67
Ambient light rejection	according to EN 60947-5-2
Vibrations	0,5 mm amplitude, 10 ... 55 Hz frequency, for every axis (EN60068-2-6)
Shock resistance	11 ms (30 G) 6 shock for every axis (EN60068-2-27)
Housing material	Polycarbonate
Lens material	PMMA, glass (mod. B00)
Operating temperature	-20 ... 55 °C
Storage temperature	-30 ... 75 °C
Weight	22 g

DIMENSIONS

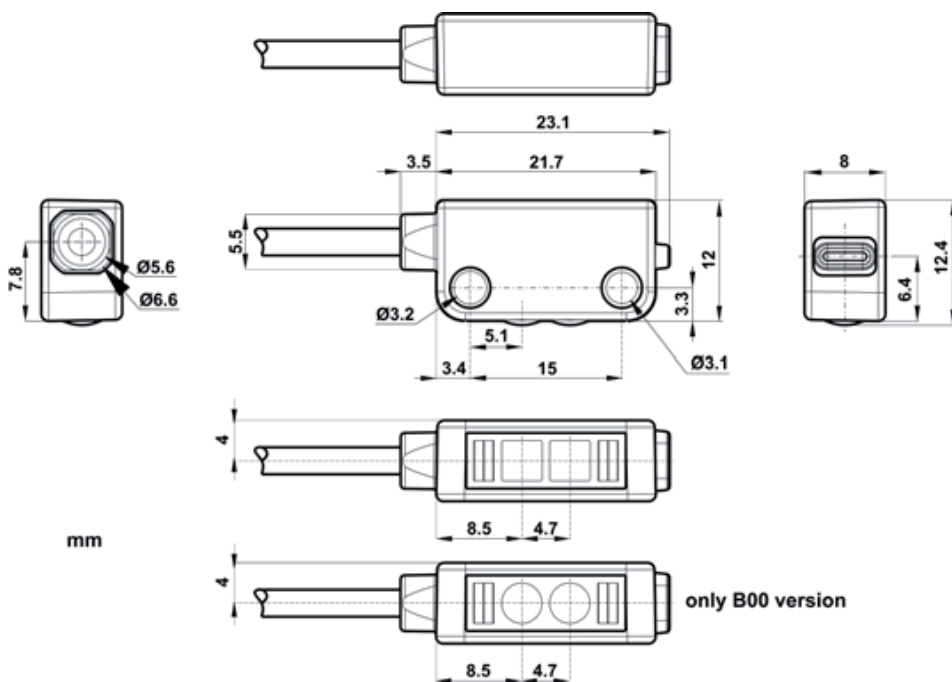

MINIATURE SENSORS

CONNECTIONS

CABLE

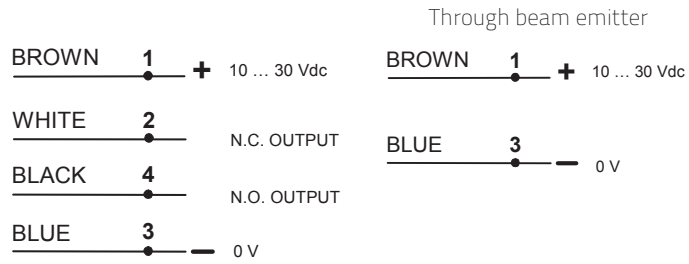

INDICATORS AND SETTINGS

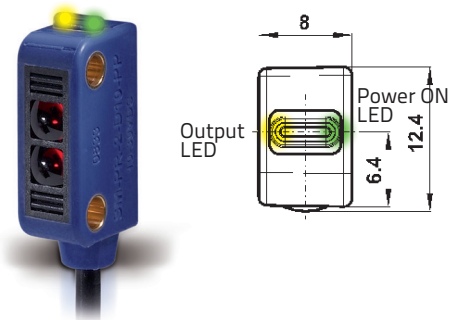

DETECTION DIAGRAMS

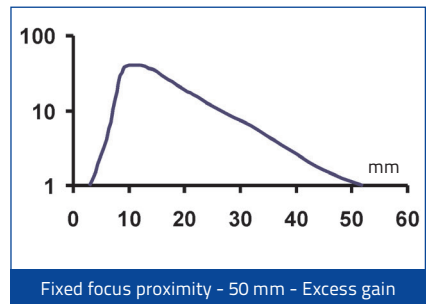
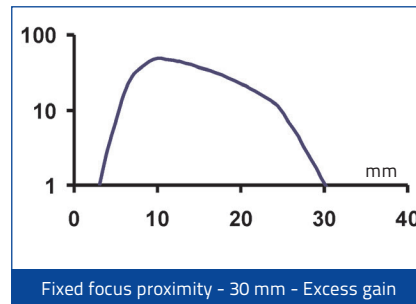
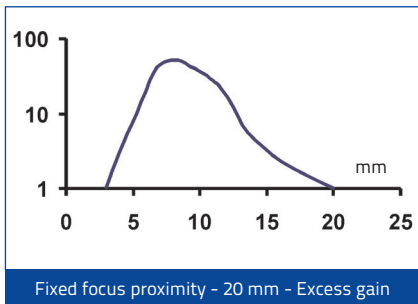
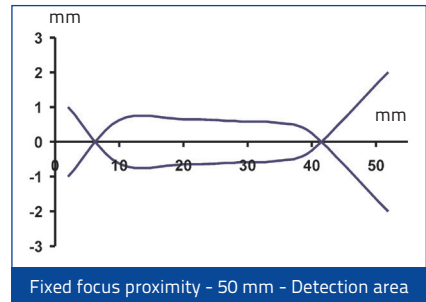
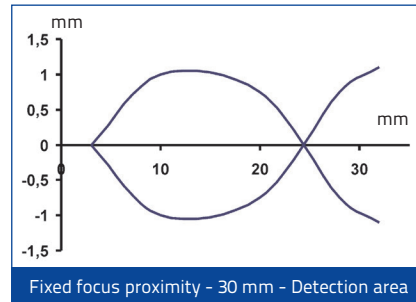
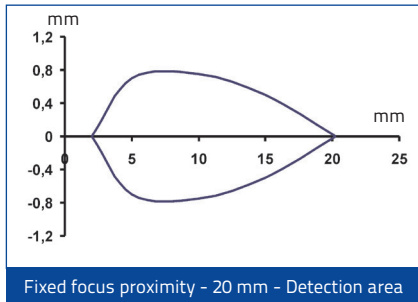
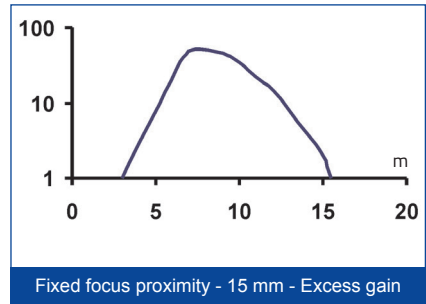
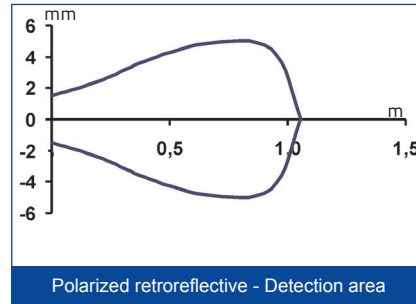
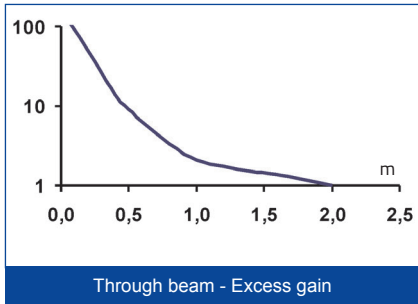
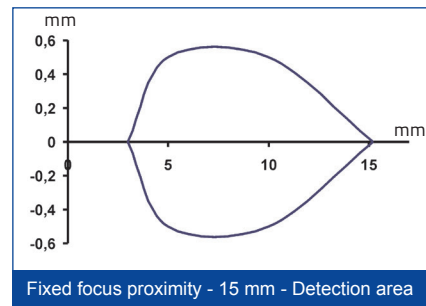
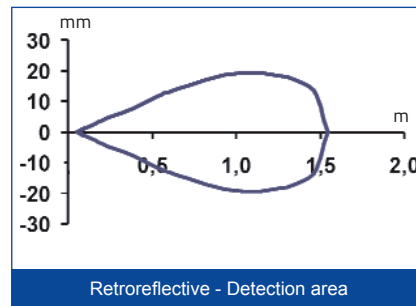
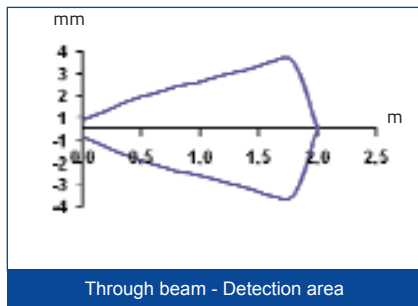



OPTIC FUNCTION	OPERATING DISTANCE	CONNECTION	OUTPUT	MODEL	ORDER No.	
Retroreflective	0,05...1,5 m	2m Cable	PNP	SM-PR-2-A00-PP	95B000060	
			NPN	SM-PR-2-A00-NN	95B000070	
Polarized retroreflective	0,1...1 m	2m Cable	PNP	SM-PR-2-B00-PP	95B000080	
			NPN	SM-PR-2-B00-NN	95B000090	
Fixed focus (short distance)	15 mm	2m Cable	PNP	SM-PR-2-D00-PP	95B000020	
			NPN	SM-PR-2-D00-NN	95B000030	
Fixed focus (normal distance)	20 mm		PNP	SM-PR-2-D10-PP	95B000140	
			NPN	SM-PR-2-D10-NN	95B000150	
Fixed focus (medium distance)	30 mm		PNP	SM-PR-2-D20-PP	95B000040	
			NPN	SM-PR-2-D20-NN	95B000050	
Fixed focus (long distance)	50 mm		PNP	SM-PR-2-D30-PP	95B000000	
			NPN	SM-PR-2-D30-NN	95B000010	
Through beam receiver	0...2 m		2m Cable	PNP	SM-PR-2-F00-PP	95B000120
				NPN	SM-PR-2-F00-NN	95B000130
		-		SM-PR-2-G00-XG	95B000160	

ACCESSORIES

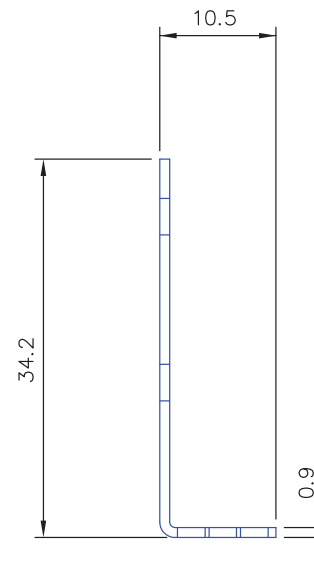
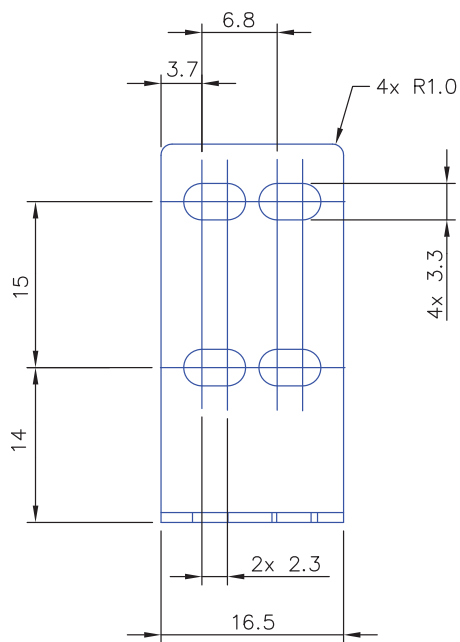
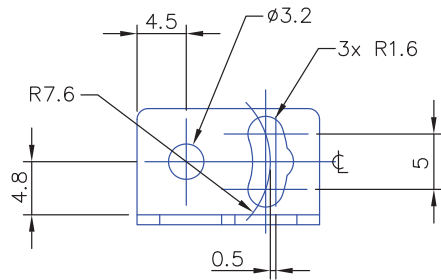

MODEL	DESCRIPTION	ORDER NO.
ST-5049	right angle bracket	95ACC6650

MINIATURE SENSORS

S3Z

Advanced line of miniature Asian style of photoelectric sensors

- 50–250 mm background suppression
- 0.7 m proximity, 150 mm with narrow beam
- 4 m polarized retroreflective
- 15 m through beam
- Standard 3-wire output configuration



APPLICATIONS

- Processing and Packaging machinery
- Electronics assembling
- Transportation lines, material handling
- Automatic warehouses
- Cosmetics and Pharmaceutical industry
- Small part detection with maximum accuracy



S3Z		
Through beam		0...15 m 0...30 m (class 1 LASER)
Polarized retroreflective		0.05...4 m 0.3...10 m (class 1 LASER)
Retroreflective for transparent (on R2 reflector)		0...2 m
Diffuse proximity		0...700 mm 50...150 mm (narrow beam)
Background suppression		50...250 mm 40...300 mm (class 1 LASER)
Power supply	Vdc	10...30 V
	Vac	
	Vac/dc	
Output	PNP	▪
	NPN	▪
	NPN/PNP	
	relay	
	other	
Connection	cable	▪
	connector	▪
	pig-tail	
Approximate dimensions (mm)		11x31x19
Housing material		PC/PBT
Mechanical protection		IP67

TECHNICAL DATA

Consumption (output current excluded)	30 mA max. (LED mod.) 35 mA max. (Laser mod.)
Light emission	red LED 650 nm (mod. S3Z...T51) red LED 665 nm (mod. S3Z...B01/C01) red LED 670 nm (mod. S3Z...M01) IR LED 850 nm (mod. S3Z...C11) IR LED 870 nm (mod. S3Z...F01/G00) red Laser 650 nm (mod. S3Z...B01/F01/G00/M01)
Setting	sensitivity trimmer, 6 turns screw (mod. S3Z...M01)
Operating mode	LIGHT/DARK trimmer (Laser mod.), LIGHT (mod. S3Z...-PL, -NL), DARK (mod. S3Z...-PD, -ND)
Indicators	yellow OUTPUT LED, green STABILITY LED (mod. S3Z...B01/C01/C11/F01), POWER ON LED (mod. S3Z...G00)
Output	PNP or NPN (short circuit protection)
Output current	100 mA max.
Saturation voltage	2 V max. (LED mod.) 1.5 V max. (Laser mod.)
Response time	1 ms max. (LED mod.) 250 μ s max. (Laser mod.)
Switching frequency	500 Hz max. (LED mod.) 2 kHz max. (Laser mod.)
Connection	2 m cable \varnothing 3,5 mm, M8 4-pole connector
Dielectric strength	500 Vac 1 min., between electronics and housing
Insulating resistance	>20 M Ω 500 Vdc, between electronics and housing
Mechanical protection	IP67
Ambient light rejection	according to EN 60947-5-2
Vibration	0.5 mm amplitude, 10 ... 55 Hz frequency, for every axis (EN60068-2-6)
Shock resistance	11 ms (30 G) 6 shock for every axis (EN60068-2-27)
Housing material	body PBT, indicators cover PC
Lens material	PMMA, PC (mod. S3Z...B01)
Operating temperature	-25 ... 55 °C (LED mod.), -10 ... 55 °C (Laser mod.)
Storage temperature	-40 ... 70 °C (LED mod.), -25 ... 70 °C (Laser mod.)
Weight	50 g max. cable vers., 10 g max. conn. vers.

DIMENSIONS

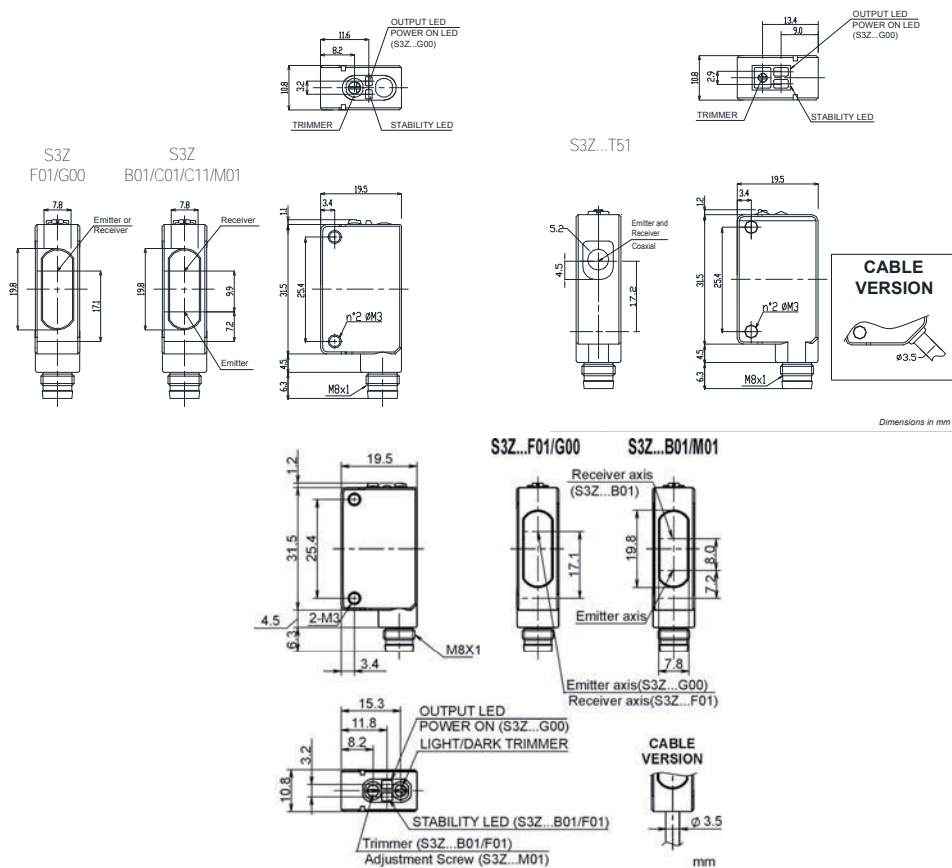

MINIATURE SENSORS

CONNECTIONS

CABLE

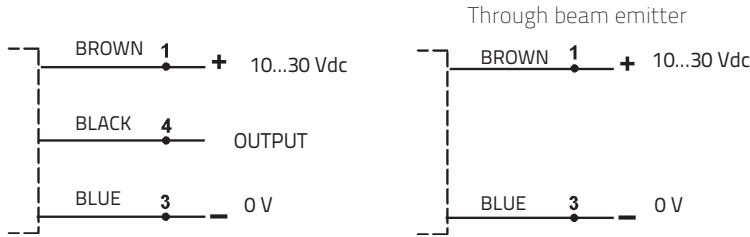

M8 CONNECTOR

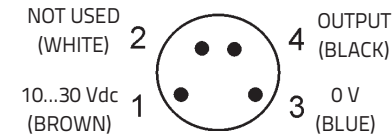

INDICATORS AND SETTINGS

S3Z...F01/G00/B01/C01/M01

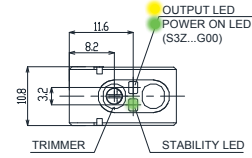

S3Z...T51

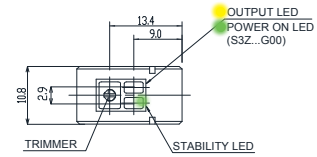

S3Z...F01/G00/B01/M01

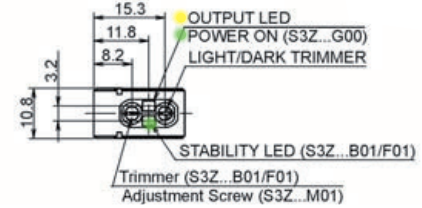
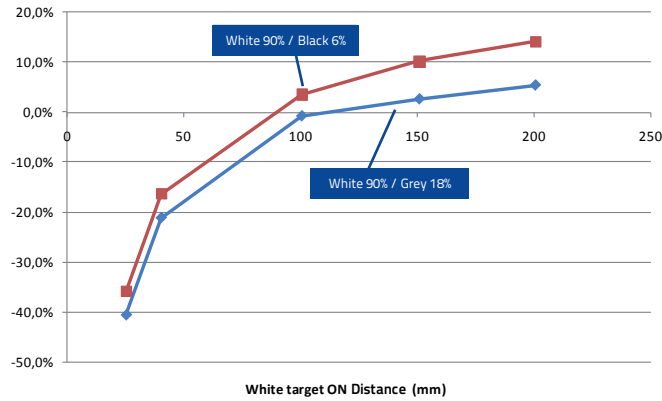
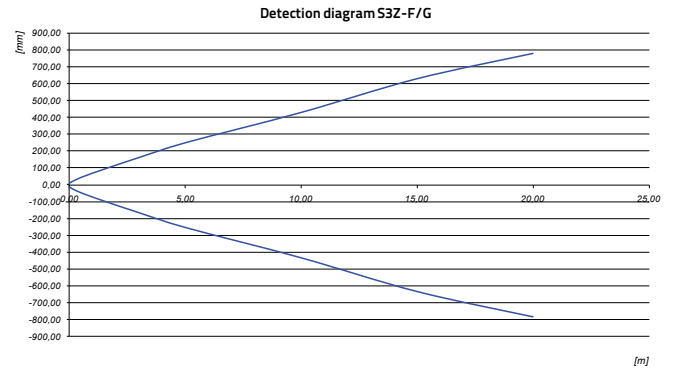

DIAGRAM LED MODELS

BACKGROUND SUPPRESSION - DISTANCE DIFFERENCE VS REFLECTANCE TARGET



THROUGH BEAM - DETECTION AREA



POLARIZED RETROREFLECTIVE - DETECTION AREA

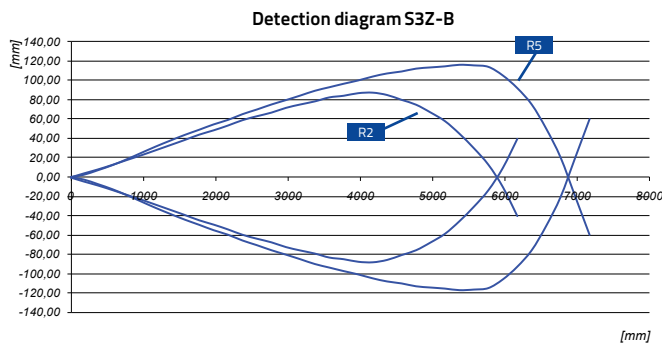

DIFFUSE PROXIMITY - DETECTION AREA

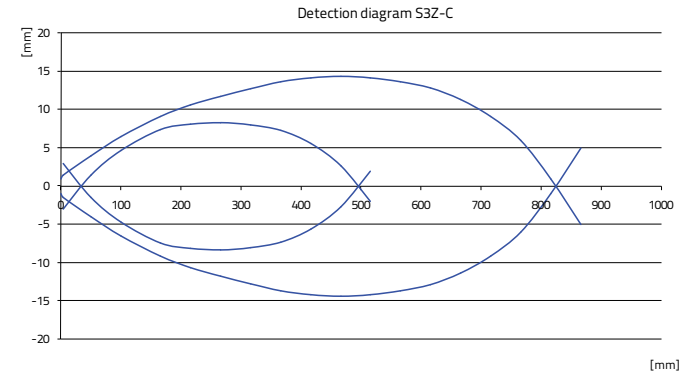

NARROW BEAM PROXIMITY - DETECTION AREA

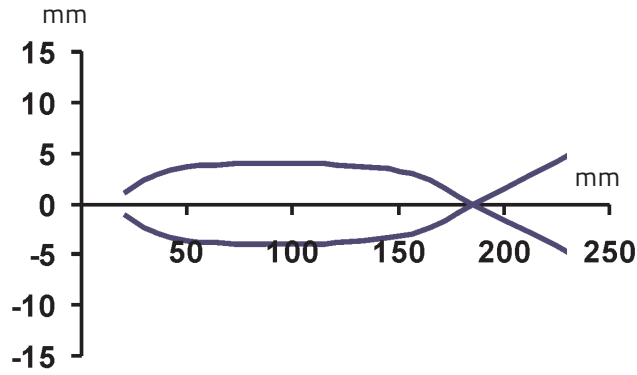

POLARIZED RETROREFLECTIVE FOR TRANSPARENT - DETECTION AREA

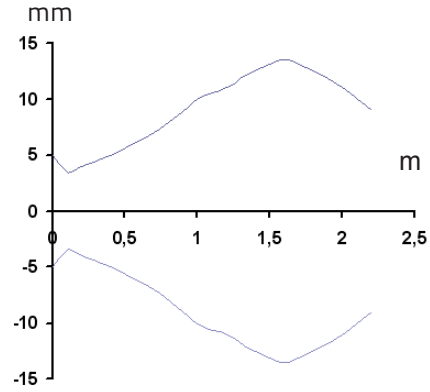

DIAGRAMS LASER MODELS

BACKGROUND SUPPRESSION - DETECTION AREA

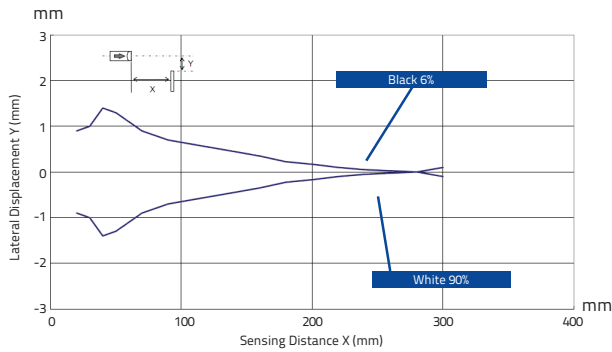

BACKGROUND SUPPRESSION - SPOT DIMENSION

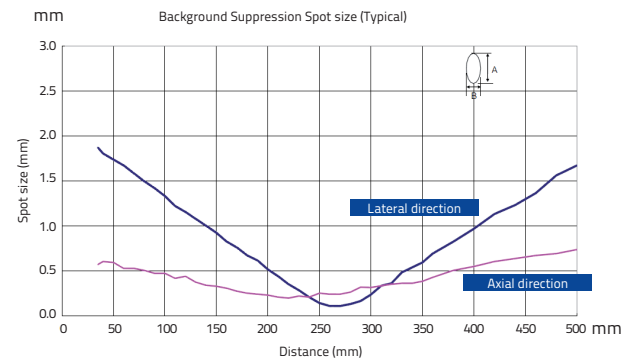

POLARIZED RETROREFLECTIVE - DETECTION AREA

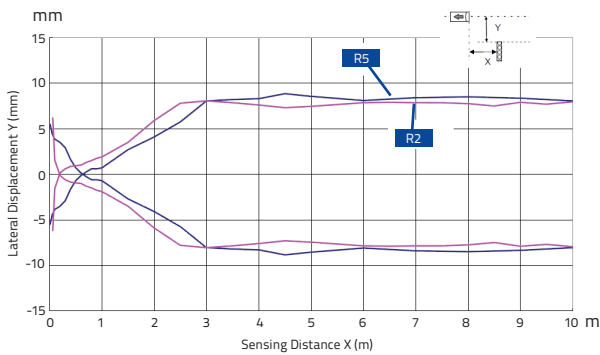

POLARIZED RETROREFLECTIVE - EXCESS GAIN

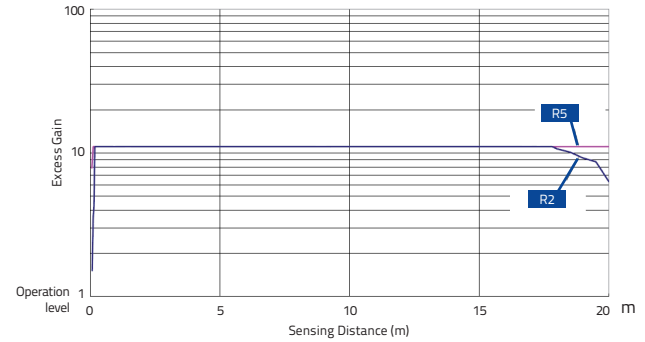

THROUGH BEAM - DETECTION AREA

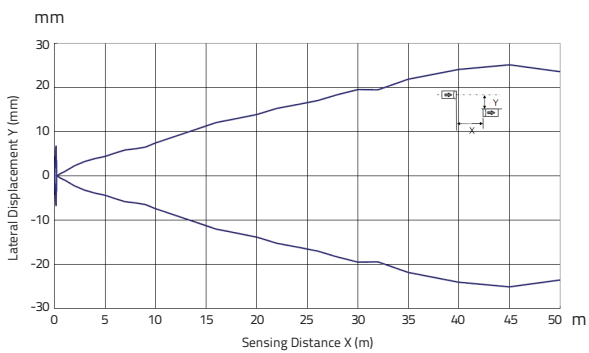

THROUGH BEAM - EXCESS GAIN

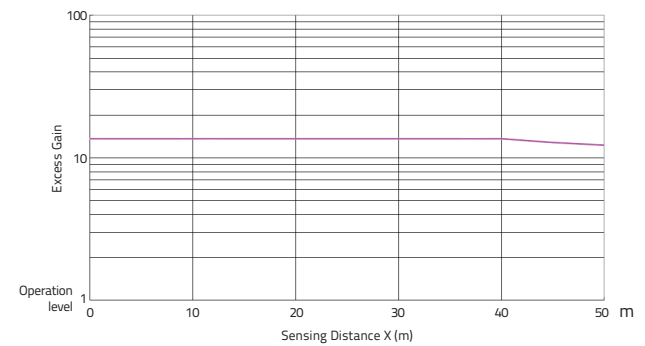

MINIATURE SENSORS

MODEL SELECTION AND ORDER INFORMATION

OPTIC FUNCTION	EMISSION	CONNECTION	OUTPUT	MODEL	ORDER No.
Narrow beam diffuse proximity	LED	2 m Cable	PNP - LIGHT	S3Z-PR-2-C01-PL	95B010040
		M8 Connector	PNP - LIGHT	S3Z-PR-5-C01-PL	95B010050
		2 m Cable	PNP - DARK	S3Z-PR-2-C01-PD	95B010060
		M8 Connector	PNP - DARK	S3Z-PR-5-C01-PD	95B010070
		2 m Cable	NPN - LIGHT	S3Z-PR-2-C01-NL	95B010200
		M8 Connector	NPN - LIGHT	S3Z-PR-5-C01-NL	95B010210
Long diffuse proximity	LED	2 m Cable	NPN - DARK	S3Z-PR-2-C01-ND	95B010220
		M8 Connector	NPN - DARK	S3Z-PR-5-C01-ND	95B010230
		2 m Cable	PNP - LIGHT	S3Z-PR-2-C11-PL	95B010001
		M8 Connector	PNP - LIGHT	S3Z-PR-5-C11-PL	95B010011
		2 m Cable	PNP - DARK	S3Z-PR-2-C11-PD	95B010021
		M8 Connector	PNP - DARK	S3Z-PR-5-C11-PD	95B010031
Polarized retroreflective	LED	2 m Cable	NPN - LIGHT	S3Z-PR-2-C11-NL	95B010161
		M8 Connector	NPN - LIGHT	S3Z-PR-5-C11-NL	95B010171
		2 m Cable	NPN - DARK	S3Z-PR-2-C11-ND	95B010181
		M8 Connector	NPN - DARK	S3Z-PR-5-C11-ND	95B010191
		2 m Cable	PNP - LIGHT	S3Z-PR-2-B01-PL	95B010081
		M8 Connector	PNP - LIGHT	S3Z-PR-5-B01-PL	95B010091
Polarized retroreflective	LED	2 m Cable	PNP - DARK	S3Z-PR-2-B01-PD	95B010101
		M8 Connector	PNP - DARK	S3Z-PR-5-B01-PD	95B010111
		2 m Cable	NPN - LIGHT	S3Z-PR-2-B01-NL	95B010241
		M8 Connector	NPN - LIGHT	S3Z-PR-5-B01-NL	95B010251
		2 m Cable	NPN - DARK	S3Z-PR-2-B01-ND	95B010261
		M8 Connector	NPN - DARK	S3Z-PR-5-B01-ND	95B010271
Polarized retroreflective	LASER	2 m Cable	PNP - DARK/LIGHT	S3Z-PH-2-B01-P	95B010440
		M8 Connector	PNP - DARK/LIGHT	S3Z-PH-5-B01-P	95B010460
		2 m Cable	NPN - DARK/LIGHT	S3Z-PH-2-B01-N	95B010450
		M8 Connector	NPN - DARK/LIGHT	S3Z-PH-5-B01-N	95B010470
		2 m Cable	PNP - LIGHT	S3Z-PR-2-FG01-PL	95B010121
		M8 Connector	PNP - LIGHT	S3Z-PR-5-FG01-PL	95B010131
Through beam	LED	2 m Cable	PNP - DARK	S3Z-PR-2-FG01-PD	95B010141
		M8 Connector	PNP - DARK	S3Z-PR-5-FG01-PD	95B010151
		2 m Cable	NPN - LIGHT	S3Z-PR-2-FG01-NL	95B010281
		M8 Connector	NPN - LIGHT	S3Z-PR-5-FG01-NL	95B010291
		2 m Cable	NPN - DARK	S3Z-PR-2-FG01-ND	95B010301
		M8 Connector	NPN - DARK	S3Z-PR-5-FG01-ND	95B010311
Through beam	LASER	2 m Cable	PNP - DARK/LIGHT	S3Z-PH-2-FG01-P	95B010520
		M8 Connector	PNP - DARK/LIGHT	S3Z-PH-5-FG01-P	95B010540
		2 m Cable	NPN - DARK/LIGHT	S3Z-PH-2-FG01-N	95B010530
		M8 Connector	NPN - DARK/LIGHT	S3Z-PH-5-FG01-N	95B010550
		2 m Cable	PNP - LIGHT	S3Z-PR-2-M01-PL	95B010331
		M8 Connector	PNP - LIGHT	S3Z-PR-5-M01-PL	95B010351
Background suppression	LED	2 m Cable	NPN - LIGHT	S3Z-PR-2-M01-NL	95B010321
		M8 Connector	NPN - LIGHT	S3Z-PR-5-M01-NL	95B010341
		2 m Cable	PNP - DARK/LIGHT	S3Z-PH-2-M01-P	95B010480
	LASER	M8 Connector	PNP - DARK/LIGHT	S3Z-PH-5-M01-P	95B010500
		2 m Cable	NPN - DARK/LIGHT	S3Z-PH-2-M01-N	95B010490
		M8 Connector	NPN - DARK/LIGHT	S3Z-PH-5-M01-N	95B010510
Polarized retroreflective for transparent	LED	2 m Cable	NPN - DARK	S3Z-PR-2-T51-ND	95B010390
		2 m Cable	PNP - DARK	S3Z-PR-2-T51-PD	95B010380
		M8 Connector	NPN - DARK	S3Z-PR-5-T51-ND	95B010370
		M8 Connector	PNP - DARK	S3Z-PR-5-T51-PD	95B010360

ACCESSORIES

ST-505

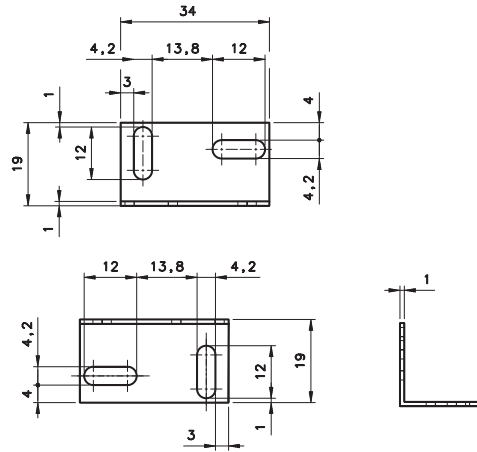

ST-5039

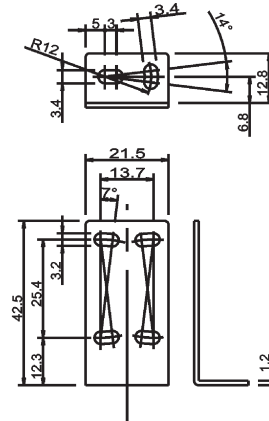

ST-5046

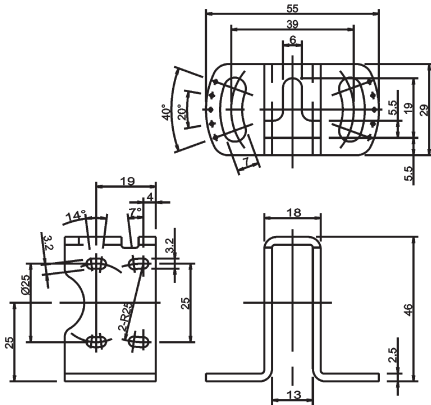

ST-5040

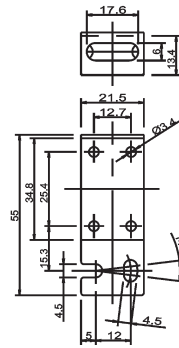

SLIT

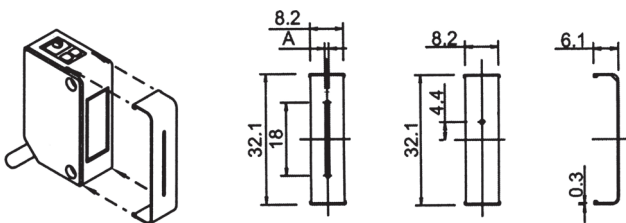

M18 ADAPTER NOSE

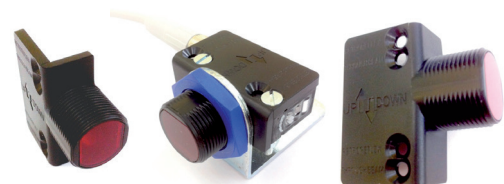

MINIATURE SENSORS

MODEL	DESCRIPTION	ORDER NO.
ST-505	lateral mounting	95ACC2800
ST-5039	L-shaped fixing bracket	95ACC2270
ST-5040	protection bracket with vertical fixing (only for cable versions)	95ACC2280
ST-5046	protection bracket with horizontal fixing	95ACC2370
S3Z-SLIT1	∅ 0,5 mm slit for through beam	95ACC2470
S3Z-SLIT2	∅ 1 mm slit for through beam	95ACC2480
S3Z-SLIT3	∅ 2 mm slit for through beam	95ACC2490
S3Z-SLIT4	0,5x18 mm slit for through beam	95ACC2500
S3Z-SLIT5	1x18 mm slit for through beam	95ACC2510
S3Z-SLIT6	2x18 mm slit for through beam	95ACC2520
ST-S3Z-M18	S3Z FIX BRK M18 THREADED NOSE	95ACC7850

CABLES

TYPE	DESCRIPTION	LENGTH	MODEL	ORDER No.
Axial M8 Connector	4-pole, grey, P.V.C.	3 m	CS-B1-02-G-03	95A251420
		5 m	CS-B1-02-G-05	95A251430
		7 m	CS-B1-02-G-07	95A251440
		10 m	CS-B1-02-G-10	95A251480
	4-pole, P.U.R.	2 m	CS-B1-02-R-02	95A251620
		5 m	CS-B1-02-R-05	95A251640
Radial M8 Connector	4-pole, grey, P.V.C.	3 m	CS-B2-02-G-03	95A251450
		5 m	CS-B2-02-G-05	95A251460
		7 m	CS-B2-02-G-07	95A251470
		10 m	CS-B2-02-G-10	95A251530
	4-pole, P.U.R.	2 m	CS-B2-02-R-02	95A251630
		5 m	CS-B2-02-R-05	95A251650



MINIATURE SENSORS

S40

High performance miniature European style photoelectric sensors

- High-performance models with Teach-in function
- Background suppression and LASER retroreflective models
- Polarized retroreflective for transparent objects
- 4-wire NO/NC output or Remote teach input



APPLICATIONS

- Processing and Packaging machinery
- Conveyor lines, material handling
- Automated warehousing



S40		
Polarized retroreflective		0,1...2,5 m
Retroreflective for transparent (on R2 reflector)		0,1...6 m (class 2 LASER)
Diffuse proximity		100...700 mm
Background suppression		5...300 mm
		40...150 mm (class 2 LASER)
		15...100 mm
		20...60 mm (class 2 LASER)
Power supply	Vdc	10...30 V
	Vac	
	Vac/dc	
Output	PNP	▪
	NPN	▪
	NPN/PNP	
	relay	
	other	
Connection	cable	▪
	connector	▪
	pig-tail	
Approximate dimensions (mm)		12x32x20
Housing material		ABS
Mechanical protection		IP67

TECHNICAL DATA

Power supply	10 ... 30 Vdc (reverse polarity protection)
Ripple	10% max.
Consumption (output current excluded)	35 mA max.
Light emission	red LED 660 nm, 640 nm (mod. S40...M03) red Laser 650 nm
Setting	teach-in push-button and remote by cable
Indicators	yellow OUTPUT LED green READY/ERROR LED
Output	NPN or PNP, 22 K Ω pull down/up resistance (short-circuit protection)
Output current	100 mA max.
Saturation voltage	2,4 V max.
Response time	0,5 ms 125 μ s (Laser mod. S40...B03/C03)
Switching frequency	1 kHz 4 kHz (Laser mod. S40...B03/C03)
Connection	M8 4-pole connector, 2 m cable 3,5 mm
Dielectric strength	500 Vac, 1 min between electronics and housing
Insulating resistance	>20 M Ω , 500 Vdc between electronics and housing
Electrical protection	class 2
Mechanical protection	IP67
Ambient light rejection	according to EN 60947-5-2
Vibrations	0,5 mm amplitude, 10 ... 55 Hz frequency, for every axis (EN60068-2-6)
Shock resistance	11 ms (30 G) 6 shock for every axis (EN60068-2-27)
Housing material	ABS UL 94V-0
Lens material	Methacrylic PMMA
Operating temperature	-20 ... +60 °C
Storage temperature	-20 ... +80 °C
Weight	40 g max. cable vers., 10 g max. conn. vers.

DIMENSIONS

M8 CONNECTOR VERSION

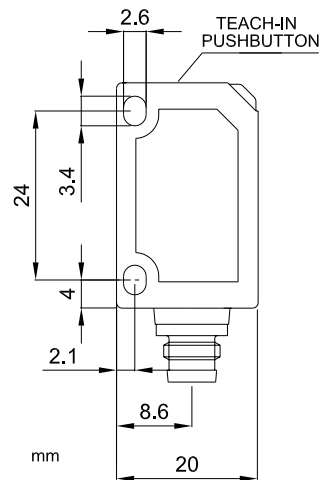
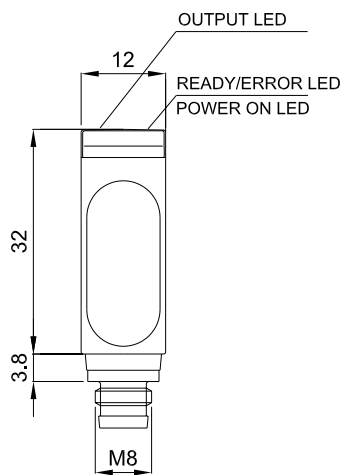

CABLE VERSION

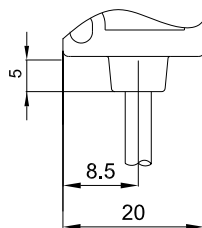

MINIATURE SENSORS

CONNECTIONS

M8 CONNECTOR

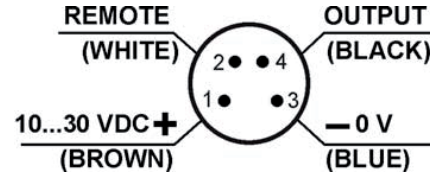

CABLE

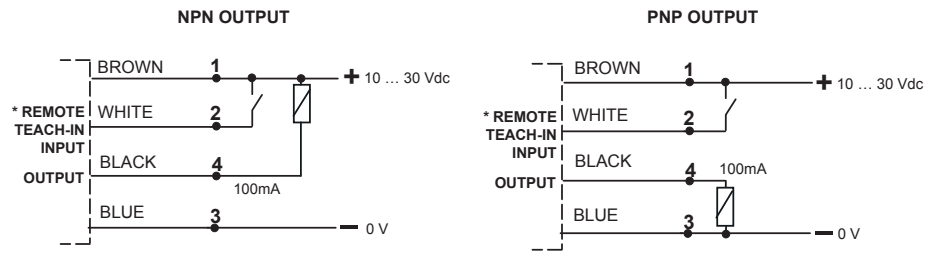

* Connect REMOTE wire to 0V if not used

INDICATORS AND SETTINGS

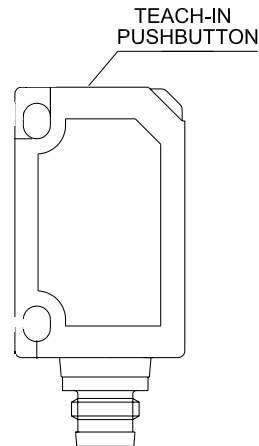
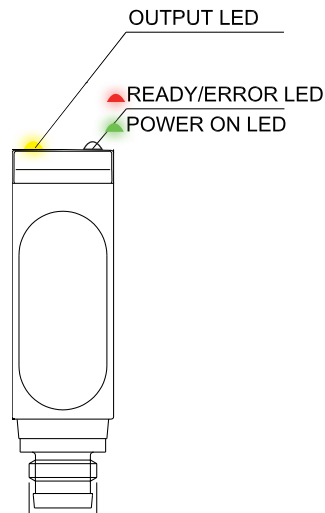

DETECTION DIAGRAMS

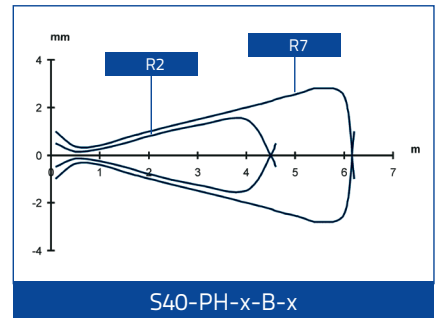
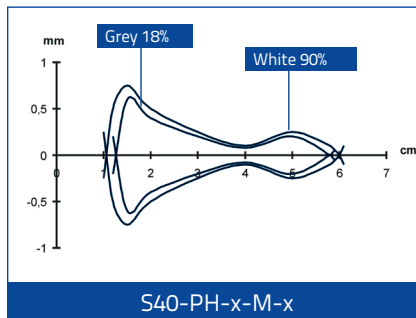
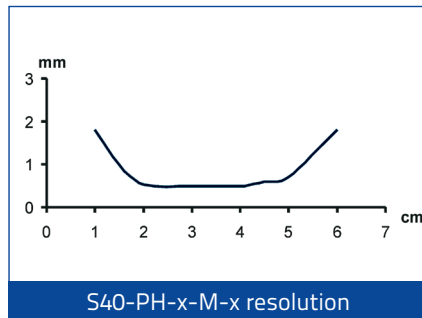
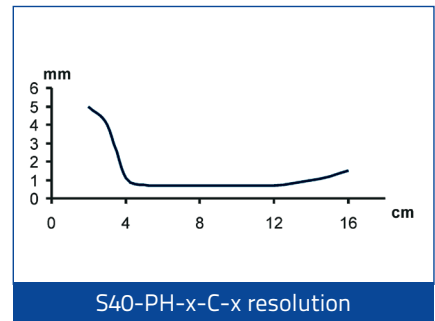
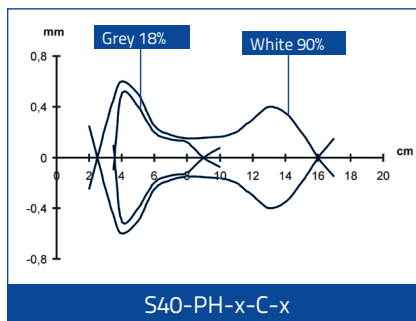
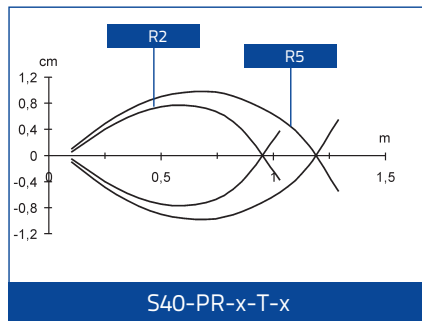
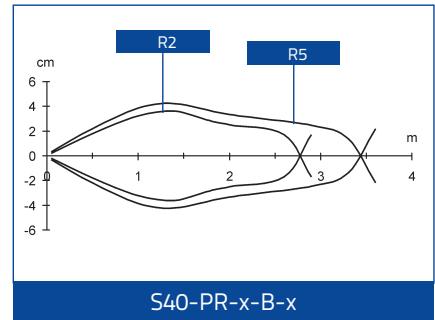
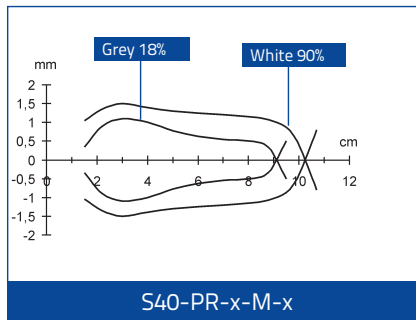
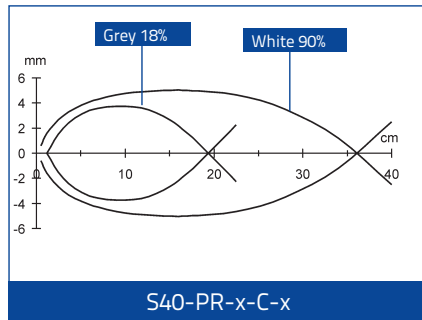

The detection diagrams indicate the typical operating distance with excess gain 1.

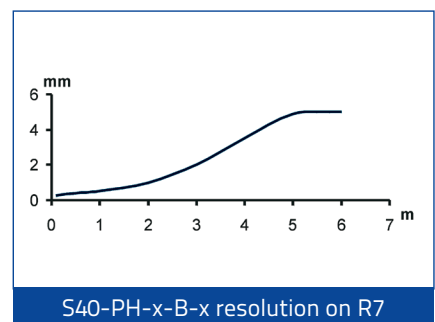

MINIATURE SENSORS

MODEL SELECTION AND ORDER INFORMATION

OPTIC FUNCTION	EMISSION	CONNECTION	OUTPUT	MODEL	ORDER No.
Polarized retroreflective	LASER	M8 connector	NPN	S40-PH-5-B03-NH	950401240
			PNP	S40-PH-5-B03-PH	950401250
	LED	2m Cable	NPN	S40-PR-2-B03-NH	950401360
			PNP	S40-PR-2-B03-PH	950401300
		M8 connector	NPN	S40-PR-5-B03-NH	950401480
			PNP	S40-PR-5-B03-PH	950401420
Diffuse proximity	LASER	M8 connector	NPN	S40-PH-5-C03-NH	950401260
			PNP	S40-PH-5-C03-PH	950401270
	LED	2m Cable	NPN	S40-PR-2-C03-NH	950401370
			PNP	S40-PR-2-C03-PH	950401310
		M8 connector	NPN	S40-PR-5-C03-NH	950401490
			PNP	S40-PR-5-C03-PH	950401430
Background suppression	LASER	2m Cable	PNP	S40-PH-2-M03-PH	950401540
		M8 connector	NPN	S40-PH-5-M03-NH	950401280
			PNP	S40-PH-5-M03-PH	950401290
	LED	2m Cable	NPN	S40-PR-2-M03-NH	950401380
		M8 connector	PNP	S40-PR-2-M03-PH	950401320
			NPN	S40-PR-5-M03-NH	950401500
PNP	S40-PR-5-M03-PH	950401440			
Retroreflective for transparent	LED	2m Cable	NPN	S40-PR-2-T03-NH	950401410
			PNP	S40-PR-2-T03-PH	950401350
		M8 connector	NPN	S40-PR-5-T03-NH	950401530
			PNP	S40-PR-5-T03-PH	950401470

ACCESSORIES

ST-505

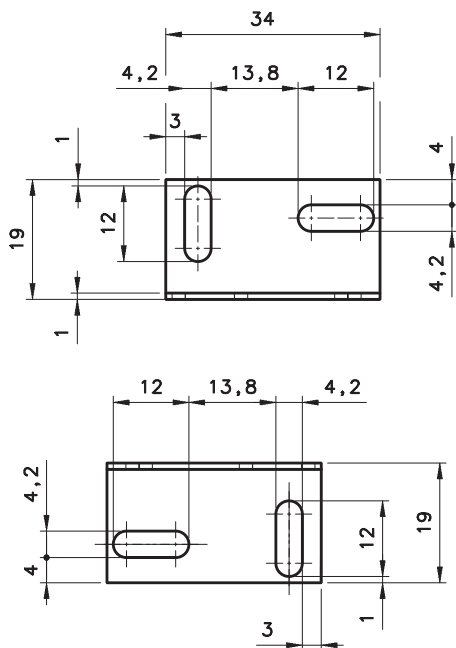

ST-5039

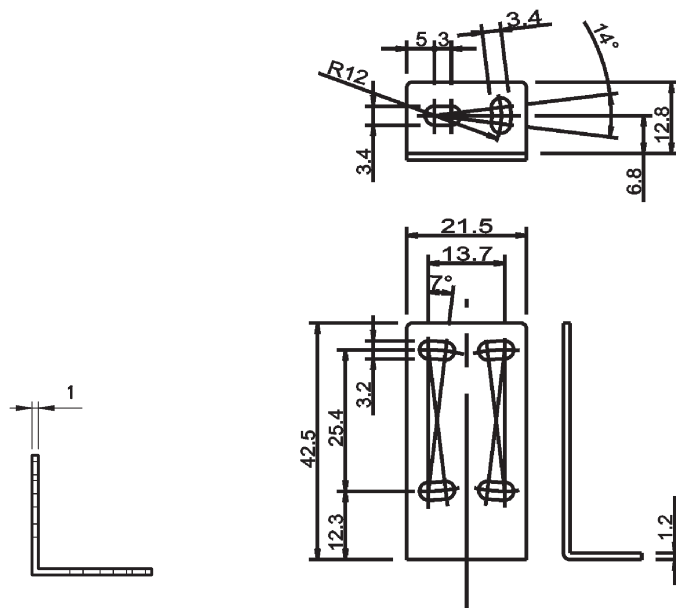

MODEL	DESCRIPTION	ORDER NO.
ST-505	lateral mounting	95ACC2800
ST-5039	L-shaped fixing bracket	95ACC2270



CABLES

TYPE	DESCRIPTION	LENGTH	MODEL	ORDER No.
Axial M8 Connector	4-pole, grey, P.V.C.	3 m	CS-B1-02-G-03	95A251420
		5 m	CS-B1-02-G-05	95A251430
		7 m	CS-B1-02-G-07	95A251440
		10 m	CS-B1-02-G-10	95A251480
	4-pole, P.U.R.	2 m	CS-B1-02-R-02	95A251620
		5 m	CS-B1-02-R-05	95A251640
Radial M8 Connector	4-pole, grey, P.V.C.	3 m	CS-B2-02-G-03	95A251450
		5 m	CS-B2-02-G-05	95A251460
		7 m	CS-B2-02-G-07	95A251470
		10 m	CS-B2-02-G-10	95A251530
	4-pole, P.U.R.	2 m	CS-B2-02-R-02	95A251630
		5 m	CS-B2-02-R-05	95A251650

MINIATURE SENSORS

S41

Basic line of miniature European style photoelectric sensors

- Cost-effective universal models with adjustment trimmer
- Polarized retroreflective for transparent objects
- 4-wire connection NO/NC output or Remote teach



APPLICATIONS

- Processing and Packaging machinery
- Conveyor lines, material handling
- Automated warehousing



S41		
Through beam		0,1...6 m
Polarized retroreflective (on R2 reflector)		0,1...2,5 m
Retroreflective for transparent (on R2 reflector)		100...700 mm
Diffuse proximity		2...350 mm
Fixed focus		110 mm
Power supply	Vdc	10...30 V
	Vac	
	Vac/dc	
Output	PNP	▪
	NPN	▪
	NPN/PNP	
	relay	
Connection	other	
	cable	▪
	connector	▪
	pig-tail	
Approximate dimensions (mm)		12x32x20
Housing material		ABS
Mechanical protection		IP67

TECHNICAL DATA

Power supply	10 ... 30 Vdc (reverse polarity protection)
Ripple	10% max.
Consumption (output current excluded)	35 mA max.
Light emission	red LED 660 nm (mod. S41...B/D/P/T) IR LED 880 nm (mod. S41...C/G/H)
Setting	sensitivity trimmer (mod. S41...B/C/T)
Operating mode	LIGHT mode (mod. S41...C/D); DARK mode (mod. S41...B/F/P/T)
Indicators	yellow OUTPUT LED green STABILITY LED (mod. S41...B/D/C/F/P), POWER LED (mod. S41...G/H)
Output	NPN or PNP, NO; NC
Output current	100 mA max.
Saturation voltage	2 V max.
Response time	1 ms
Switching frequency	500 Hz max.
Connection	M8 4-pole connector, 2 m cable \varnothing 3,5 mm
Dielectric strength	500 Vac, 1 min between electronics and housing
Insulating resistance	>20 M Ω , 500 Vdc between electronics and housing
Electrical protection	class 2
Mechanical protection	IP66 (mod. S41...B/C/T), IP67 (mod. S41...D/F/G/P/H)
Ambient light rejection	according to EN 60947-5-2
Vibrations	0,5 mm amplitude, 10 ... 55 Hz frequency, for every axis (EN60068-2-6)
Shock resistance	11 ms (30 G) 6 shock for every axis (EN60068-2-27)
Housing material	ABS UL 94V-0
Lens material	PMMA plastic
Operating temperature	-25 ... +55 °C
Storage temperature	-25 ... +70 °C
Weight	40 g max. cable vers., 10 g max. conn. vers.

DIMENSIONS

CABLE VERSION

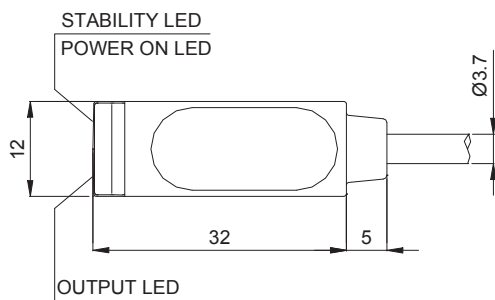
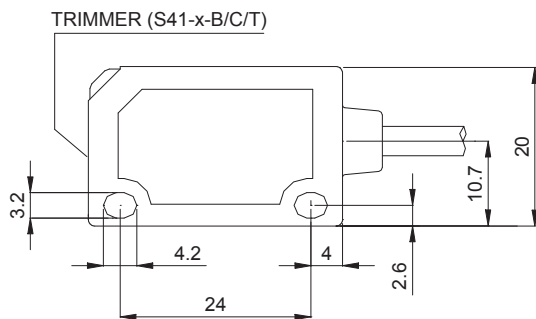

M8 CONNECTOR VERSION

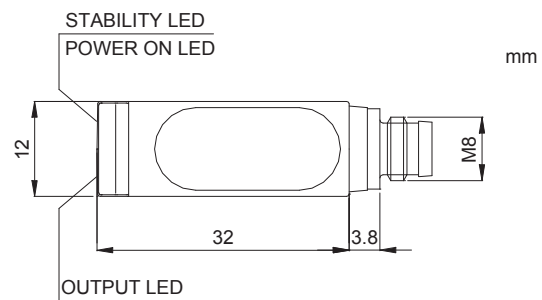
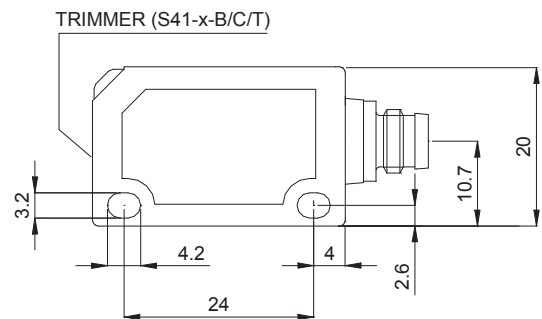

mm

MINIATURE SENSORS

CONNECTIONS

CABLE

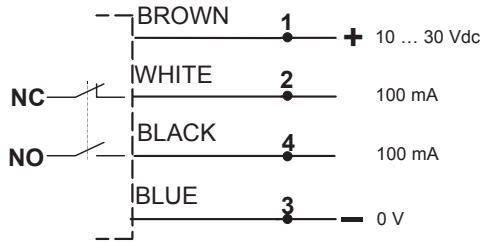

Through beam emitter

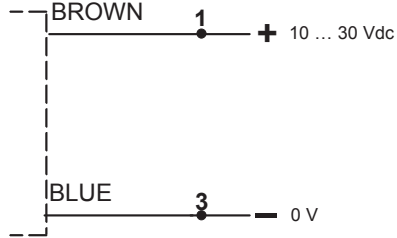

M8 CONNECTOR

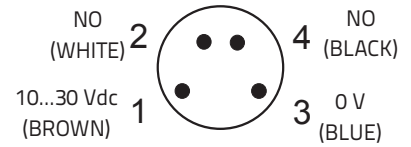

INDICATORS AND SETTINGS

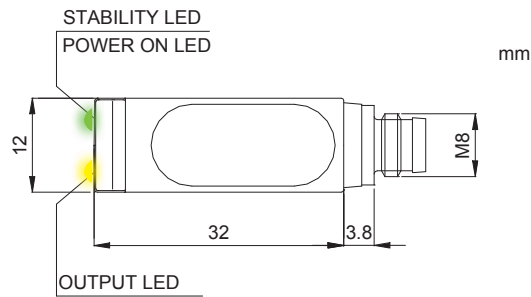
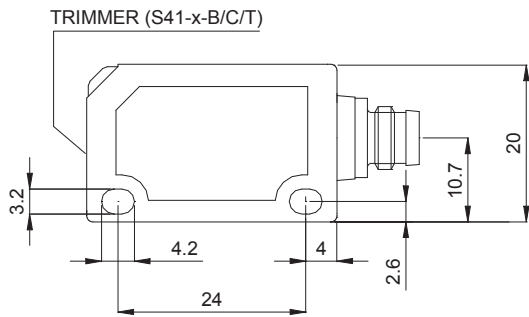

DETECTION DIAGRAMS

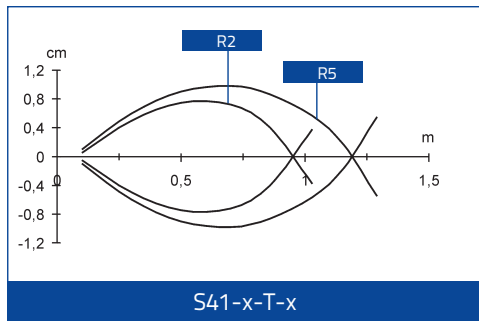
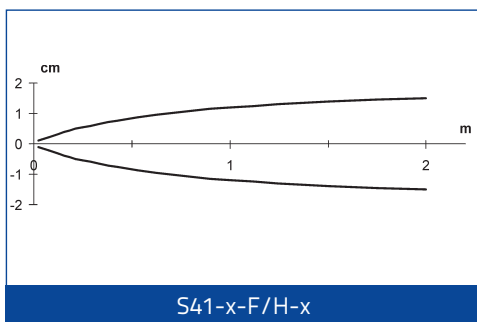
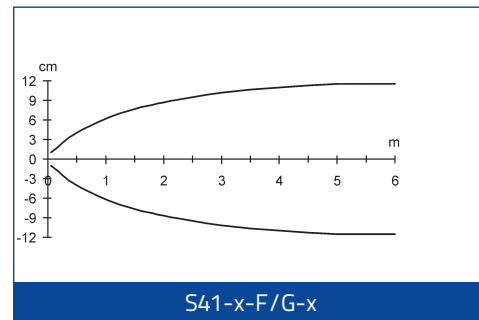
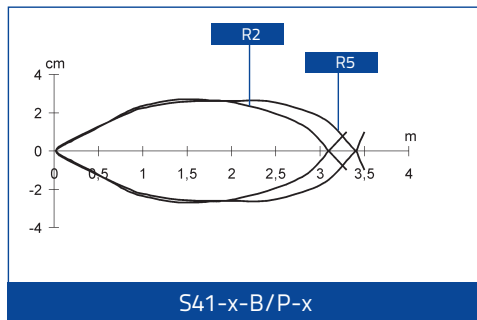
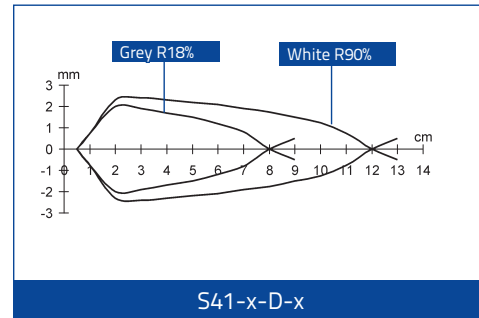
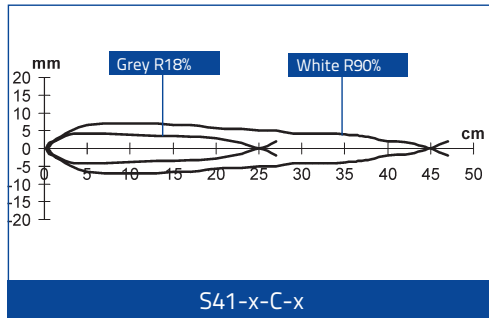

The detection diagrams indicate the typical operating distance with excess gain 1.

MINIATURE SENSORS

MODEL SELECTION AND ORDER INFORMATION

OPTIC FUNCTION	ADJUSTMENT TRIMMER	CONNECTION	OUTPUT	MODEL	ORDER No.
Polarized retroreflective	Present	2m Cable	NPN	S41-2-B-N	950701150
			PNP	S41-2-B-P	950701000
		MB Connector	NPN	S41-5-B-N	950701210
			PNP	S41-5-B-P	950701050
Polarized retroreflective	Absent	2m Cable	NPN	S41-2-P-N	950701190
			PNP	S41-2-P-P	950701100
		Connector	NPN	S41-5-P-N	950701250
			PNP	S41-5-P-P	950701110
Diffuse proximity	Present	2m Cable	NPN	S41-2-C-N	950701160
			PNP	S41-2-C-P	950701010
		MB Connector	NPN	S41-5-C-N	950701120
			PNP	S41-5-C-P	950701060
Fixed focus	Absent	2m Cable	NPN	S41-2-D-N	950701170
			PNP	S41-2-D-P	950701020
		MB Connector	NPN	S41-5-D-N	950701230
			PNP	S41-5-D-P	950701070
Through beam receiver	Absent	2m Cable	NPN	S41-2-F-N	950701180
			PNP	S41-2-F-P	950701030
		MB Connector	NPN	S41-5-F-N	950701240
			PNP	S41-5-F-P	950701080
Through beam emitter	Absent	2m Cable	-	S41-2-G	950701040
		MB Connector	-	S41-5-G	950701090
Through beam emitter with narrow beam	Absent	-	-	S41-2-H	950701045
		MB Connector	-	S41-5-H	950701095
Retroreflective for transparent	Present	2m Cable	NPN	S41-2-T-N	950701200
			PNP	S41-2-T-P	950701130
		MB Connector	NPN	S41-5-T-N	950701260
			PNP	S41-5-T-P	950701140

ACCESSORIES

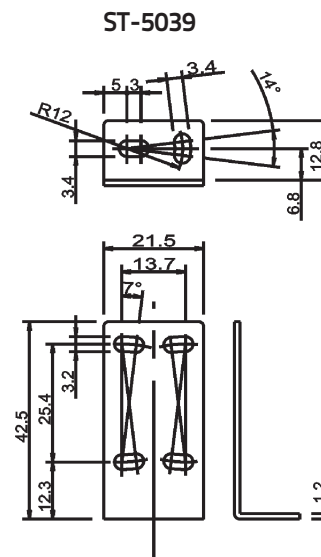
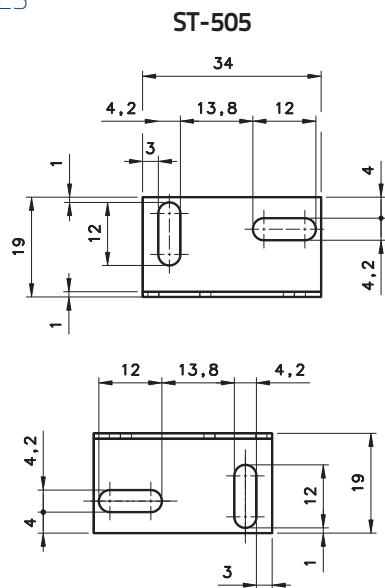

MODEL	DESCRIPTION	ORDER NO.
ST-505	lateral mounting	95ACC2800
ST-5039	L-shaped fixing bracket	95ACC2270



CABLES

TYPE	DESCRIPTION	LENGTH	MODEL	ORDER No.
Axial M8 Connector	4-pole, grey, P.V.C.	3 m	CS-B1-02-G-03	95A251420
		5 m	CS-B1-02-G-05	95A251430
		7 m	CS-B1-02-G-07	95A251440
		10 m	CS-B1-02-G-10	95A251480
	4-pole, P.U.R.	2 m	CS-B1-02-R-02	95A251620
		5 m	CS-B1-02-R-05	95A251640
Radial M8 Connector	4-pole, grey, P.V.C.	3 m	CS-B2-02-G-03	95A251450
		5 m	CS-B2-02-G-05	95A251460
		7 m	CS-B2-02-G-07	95A251470
		10 m	CS-B2-02-G-10	95A251530
	4-pole, P.U.R.	2 m	CS-B2-02-R-02	95A251630
		5 m	CS-B2-02-R-05	95A251650



MINIATURE SENSORS

S45

High Performance european style miniature sensor all-in-one family

- Red LED and Laser emissions
- Precise risk free laser class 1 emission
- Diffused LED proximity 800mm
- Background Suppression 400mm
- Retroreflective Class 1 Laser 15m/Red LED 7m
- Through beam Class 1 Laser 20m/Red LED 15m
- IP69K housing
- 2m Cable or metal M8 4 pole version
- PNP or NPN output with remote teach in input
- High speed RGB and white emission contrast sensor
- High precision distance sensor up to 200 mm



APPLICATIONS

- Processing and Packaging machinery
- Cosmetic and Pharmaceutical industry
- Electronics assembling
- Conveyor lines, material handling
- Automotive industry
- Print and paper industry
- Small part detection with maximum accuracy



S45		
Through beam		20m. (Laser Class1) 15m. (Red Led)
Polarized Retroreflective		15m. (Laser Class1) 7m. (Red Led)
Autocollimated Retroreflective for Transparent objects		2m. (Red Led)
Autocollimated Retroreflective		2m. (Red Led)
Diffused proximty		250mm. (Laser Class1) 800mm. (Red Led)
Background suppressor		120mm. (Laser Class 1) 200mm. (Red Led) 400mm. (Red Led)
Distance sensor		80mm. (Red Led) 200mm. (Red Led)
Contrast Sensor		12mm. (White)
		12mm. (RGB)
Pwer Supply	Vdc	10...30 V
	Vac	
	Vac/Vdc	
Output	PNP	▪
	NPN	▪
	NPN/PNP	
	relay	
	other	Push Pull (Wxx, Yxx), Analog 0...10 V (Yxx)
Connection	cable	▪
	connector	▪
	pig-tail	
Approximate dimensions (mm)		34mm. x 20mm. X 12mm.
Housing material		ABS(Housing), PMMA (Optics)
Mechanical protection		IP67 & IP69K

TECHNICAL DATA

Power supply	10...30 Vdc
Ripple	10% max.
Consumption (Load current excluded)	≤ 30 mA
Light emission	Red LED 632 nm, Red Laser 650 nm
Setting	Push Button TEACH-IN
Indicators	LED Green Operating Voltage LED Yellow Output Status
Output	NPN, PNP, Push Pull
Output current	100 mA
Saturation voltage	2 V max
Response time	500 μs 333 μs (CO3 Laser) 250 μs (F/G Laser) 50 μs (W03, W33) 20 μs (W13, W43) ≤ 1000Hz
Switching frequency	≤ 1500Hz (CO3 Laser) ≤ 2000 Hz (F/G Laser) ≤ 10 kHz (W03, W33) ≤ 25 kHz (W13, W43)
Connection	Plastic M8 4-pole connector, Metal M8 4-pole connector 2 m cable
Dielectric strength	500 Vac, 1min between electronic and housing
Insulating resistance	>20M OHM, 500 Vdc between electronic and housing
Electrical protection	class 2
Mechanical protection	IP67 & IP69K
Ambient light rejection	according to EN 60947-5-2
Vibrations	0,5mm amplitude, 10...55Hz frequency, for every axis (EN60068-2-6)
Shock resistance	11 ms (30G) 6 shock for every axis (EN60068-2-27)
Housing material	ABS
Lens material	PMMA
Operating temperature	-20...+60 °C
Storage temperature	-20...+80 °C
Weight	10g. with connector, 40g. with cable

DIMENSIONS

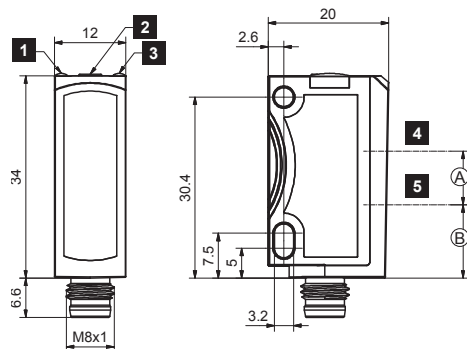

	S45-PR-2(5)-M03 S45-PR-5-Y03	S45-PR-2(5)-M13 S45-PR-5-Y13	S45-PR-2(5)-C03 S45-PR-B03	S45-PH-5-M03	S45-PH-5-C03 S45-PH-B03	S45-PR-G00	S45-PH-G00	S45-PR(PH)-F03
A	9	11.75	10.8	8.8	8.8	11.5	13.5	
B	12.3	11	11.5	12.5	13.5			22.3

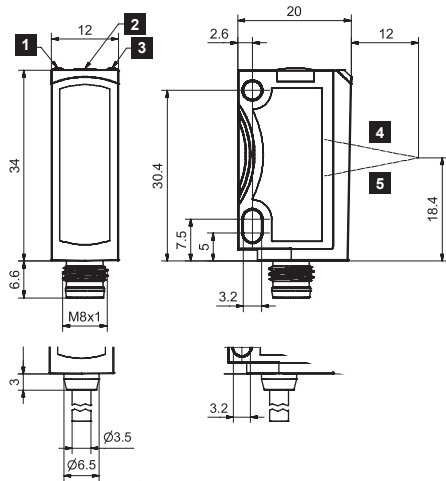

S45-PR-X-WXX-OH

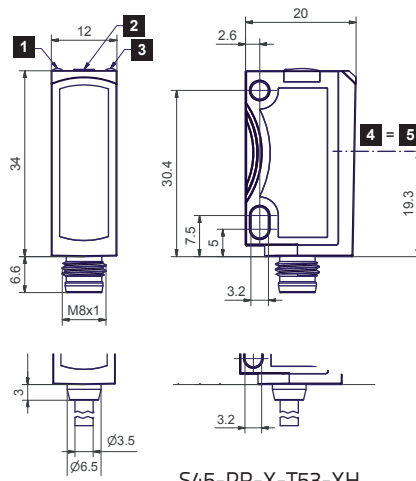

S45-PR-X-T53-XH
S45-PR-X-B53-XH

1	Yellow LED 1)
2	Button
3	Green LED 2)
4	Receiver axis
5	Emitter axis

- 1) switching output indicator
- 2) operating voltage indicator

MINIATURE SENSORS

CONNECTIONS

CABLE

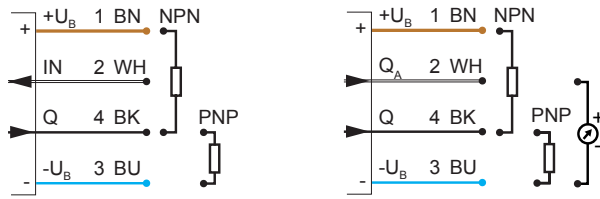

WXX, YXX

M8 CONNECTOR

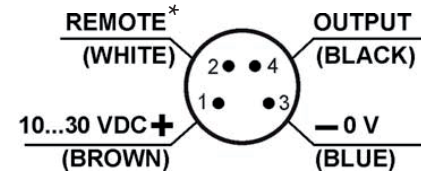

* Analog out YXX

INDICATORS AND SETTINGS

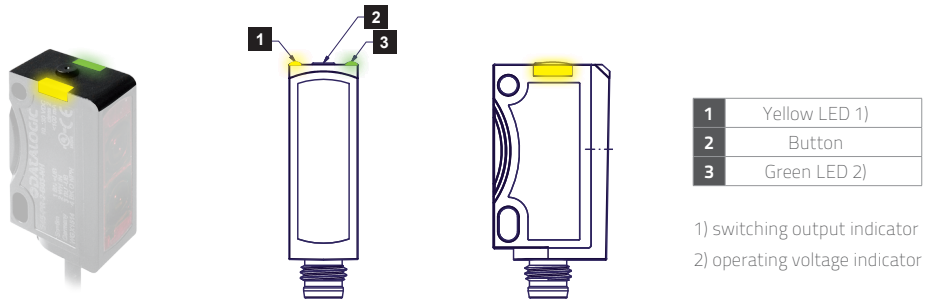

DETECTION DIAGRAMS

BACKGROUND SUPPRESSOR

DETECTION SPOT SIZE

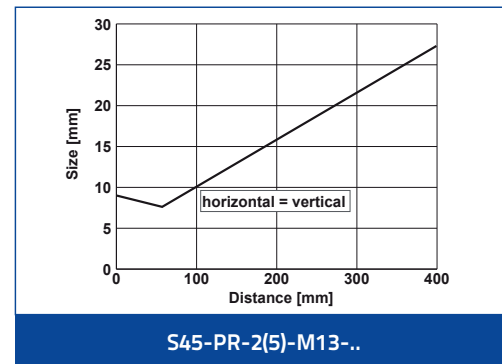
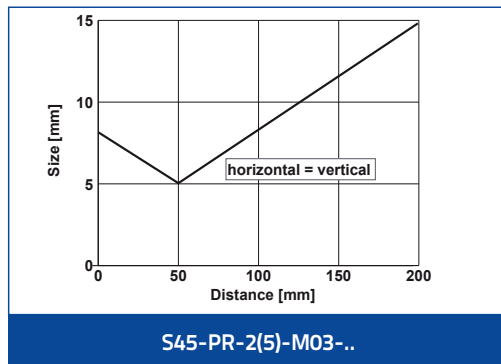

B/W SHIFT

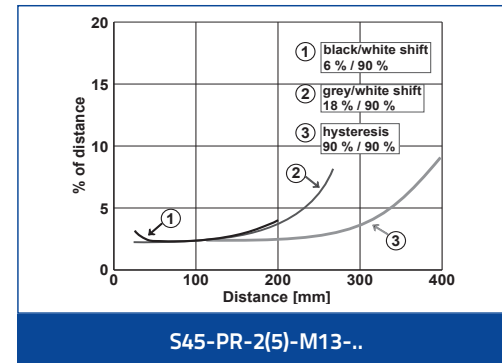
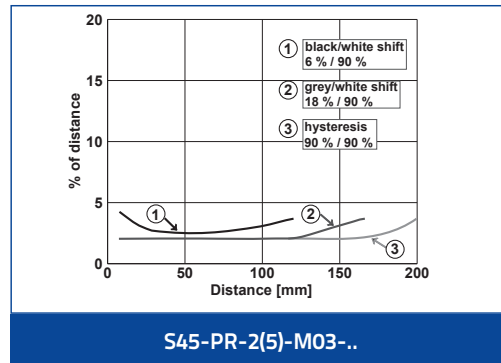

ENERGETIC DIFFUSED

DETECTION SPOT SIZE

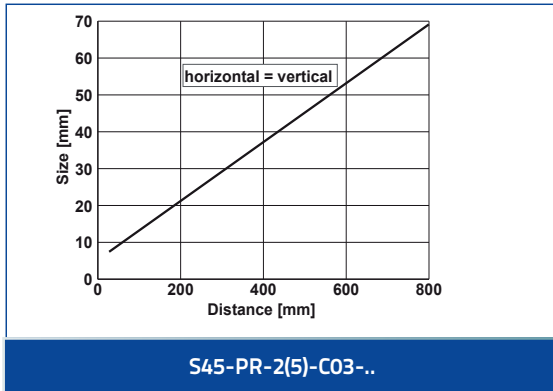

EXCESS GAIN

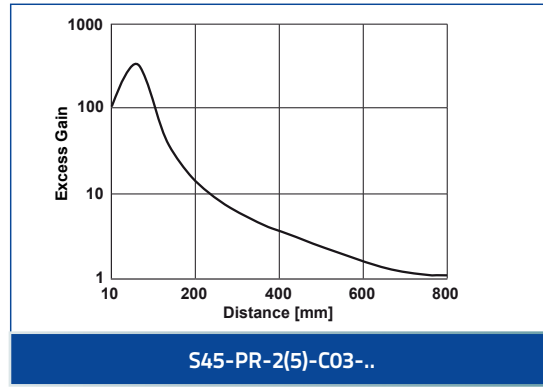

RETROREFLECTIVE POLARIZED

DETECTION SPOT SIZE

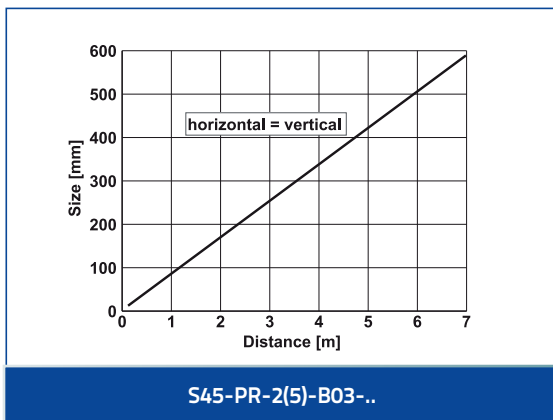

EXCESS GAIN

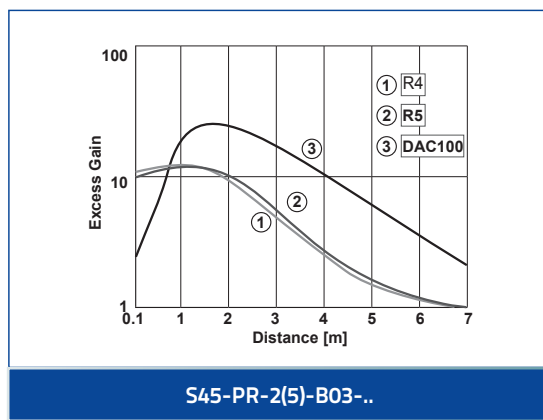

COAXIAL RETROREFLECTIVE POLARIZED

DETECTION SPOT SIZE

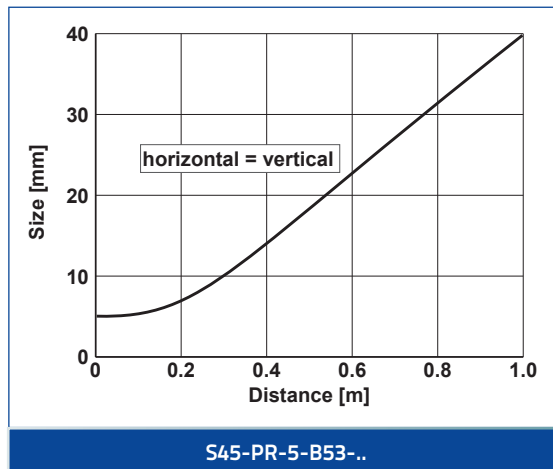

RETROREFLECTIVE FOR TRANSPARENT

DETECTION SPOT SIZE

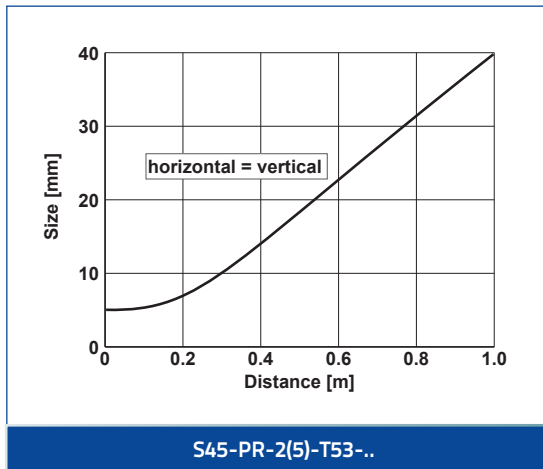

MINIATURE SENSORS

THROUGH BEAM

DETECTION SPOT SIZE

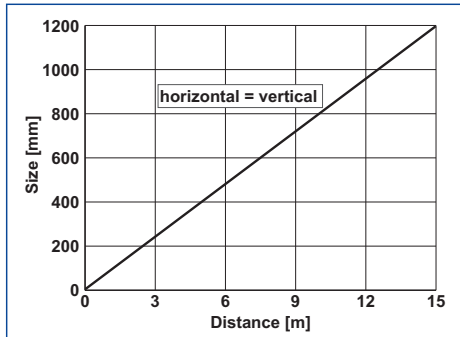

S45-PR-2(5)-F03-../S45-PR-2(5)-G00-XE

EXCESS GAIN

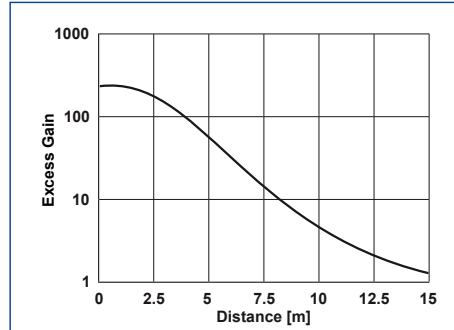

S45-PR-2(5)-F03-../S45-PR-2(5)-G00-XE

LASER BACKGROUND SUPPRESSOR

DETECTION SPOT SIZE

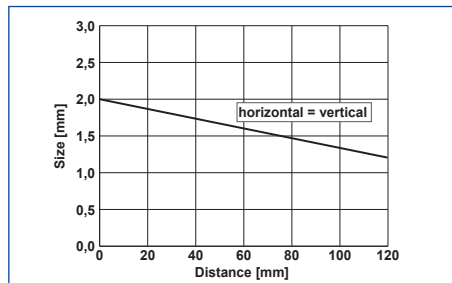

S45-PH-5-M03-..

B/W SHIFT

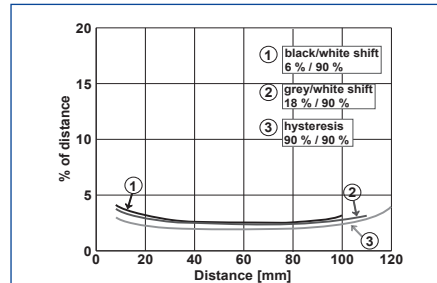

S45-PH-5-M03-..

LASER ENERGETIC DIFFUSED

DETECTION SPOT SIZE

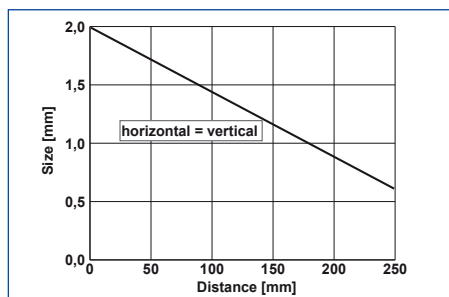

S45-PH-5-C03-..

EXCESS GAIN

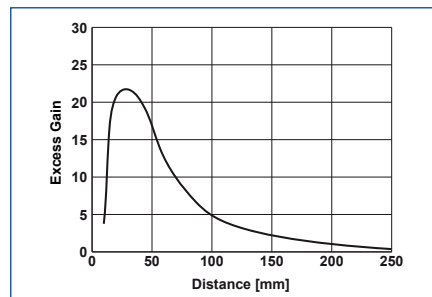

S45-PH-5-C03-..

LASER RETROREFLECTIVE POLARIZED

DETECTION SPOT SIZE

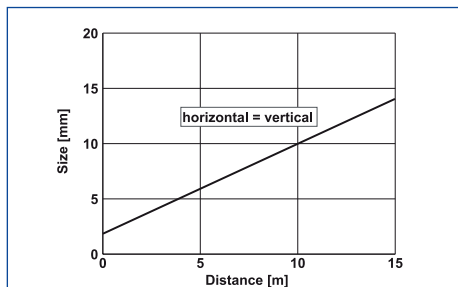

S45-PH-5-B03-..

EXCESS GAIN

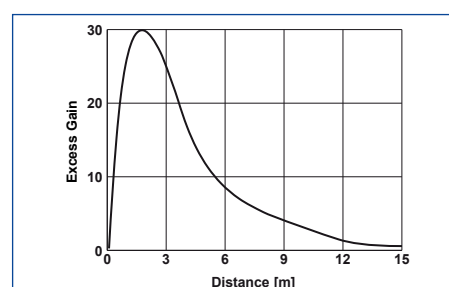

S45-PH-5-B03-..

LASER THROUGH BEAM

DETECTION SPOT SIZE

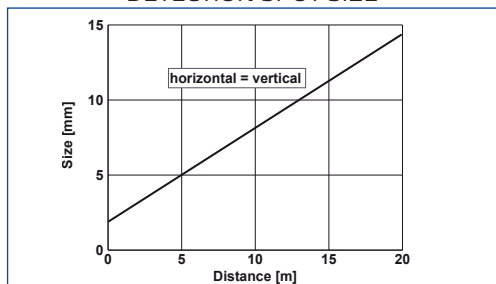

S45-PH-5-F03-../S45-PH-5-G00-XE

EXCESS GAIN

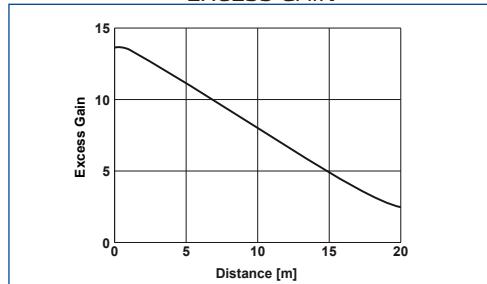

S45-PH-5-F03-../S45-PH-5-G00-XE

CONTRAST SENSOR

READING DIAGRAM

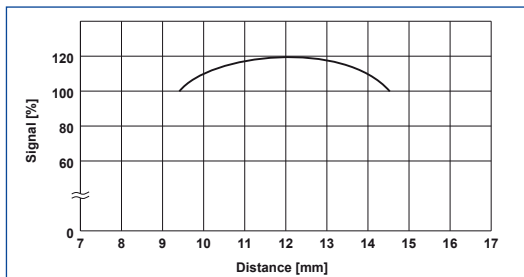

S45-PR-5-W13/-W03-..

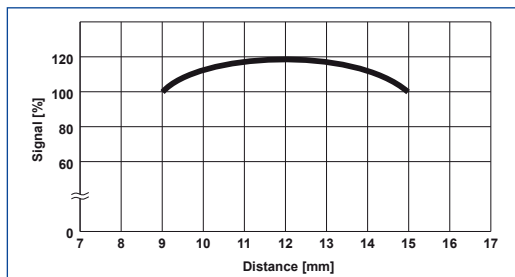

S45-PR-5-W43/-W33-..

DISTANCE SENSOR

DETECTION SPOT SIZE

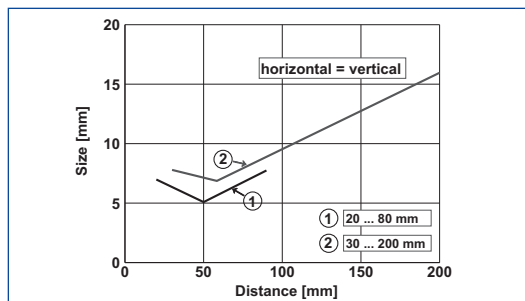

S45-PR-5-Y03/-Y13-..

SCANNING PROPERTIES

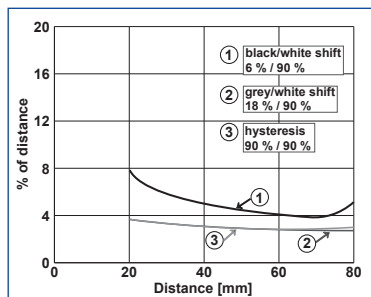

S45-PR-5-Y03-.. (characteristic Q)

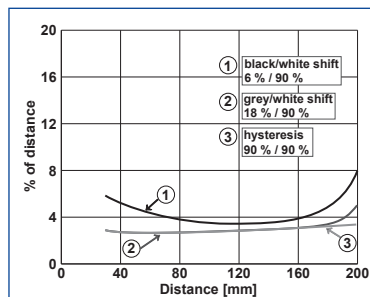

S45-PR-5-Y13-.. (characteristic Q)

MINIATURE SENSORS

MODEL SELECTION AND ORDER INFORMATION

OPTIC FUNCTION	EMISSION	CONNECTION	OUTPUT	MODEL	ORDER NO.
Diffused proximity	LED	2m Cable	PNP	S45-PR-2-C03-PH	950411220
			NPN	S45-PR-2-C03-NH	950411210
		M8	PNP	S45-PR-5-C03-PH	950411240
			NPN	S45-PR-5-C03-NH	950411230
	LASER	M8	PNP	S45-PH-5-C03-PH	950411260
			NPN	S45-PH-5-C03-NH	950411250
Polarized Retroreflective	LED	2m Cable	PNP	S45-PR-2-B03-PH	950411100
			NPN	S45-PR-2-B03-NH	950411090
		M8	PNP	S45-PR-5-B03-PH	950411120
			NPN	S45-PR-5-B03-NH	950411110
	LASER	M8	PNP	S45-PH-5-B03-PH	950411140
			NPN	S45-PH-5-B03-NH	950411130
Polarized retroreflective autocollimated for transparent	LED	2m Cable	PNP	S45-PR-2-T53-PH	950411160
			NPN	S45-PR-2-T53-NH	950411150
		M8	PNP	S45-PR-5-T53-PH	950411180
			NPN	S45-PR-5-T53-NH	950411170
Polarized retroreflective autocollimated	LED	M8	PNP	S45-PR-5-B53-PH	950411200
			NPN	S45-PR-5-B53-NH	950411190
Through beam	LED	2m Cable	-	S45-PR-2-G00-XE	950411000
			PNP	S45-PR-2-F03-PH	950411020
			NPN	S45-PR-2-F03-NH	950411010
		M8	-	S45-PR-5-G00-XE	950411030
			PNP	S45-PR-5-F03-PH	950411050
			NPN	S45-PR-5-F03-NH	950411040
	LASER	M8	-	S45-PH-5-G00-XE	950411060
			PNP	S45-PH-5-F03-PH	950411080
			NPN	S45-PH-5-F03-NH	950411070
			PNP	S45-PR-2-M03-PH	950411280
Background suppressor 200mm	LED	2m Cable	NPN	S45-PR-2-M03-NH	950411270
			PNP	S45-PR-5-M03-PH	950411300
		M8	NPN	S45-PR-5-M03-NH	950411290
			PNP	S45-PR-2-M13-PH	950411320
Background suppressor 400mm	LED	2m Cable	NPN	S45-PR-2-M13-NH	950411310
			PNP	S45-PR-5-M13-PH	950411340
		M8	NPN	S45-PR-5-M13-NH	950411330
			PNP	S45-PH-5-M03-PH	950411360
Background suppressor laser	LASER	M8	NPN	S45-PH-5-M03-NH	950411350
			PNP	S45-PR-5-Y03-PV	950411380
Distance sensor	LED	M8	NPN	S45-PR-5-Y03-NV	950411370
Distance sensor	LED	M8	PNP	S45-PR-5-Y13-PV	950411400
			NPN	S45-PR-5-Y13-NV	950411390
Contrast Sensor 10kHz	WHITE	M8	PUSH-PULL	S45-PR-5-W03-OH	950411420
	RGB		PUSH-PULL	S45-PR-5-W13-OH	950411410
Contrast Sensor 25kHz	WHITE	M8	PUSH-PULL	S45-PR-5-W33-OH	950411440
	RGB		PUSH-PULL	S45-PR-5-W43-OH	950411430

ACCESSORIES

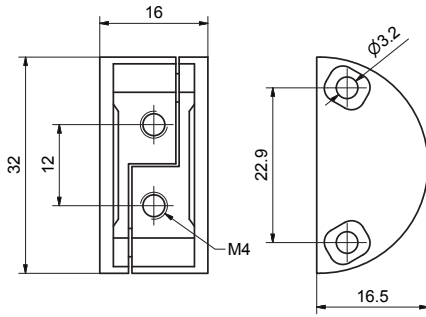

ST-S45-DVT

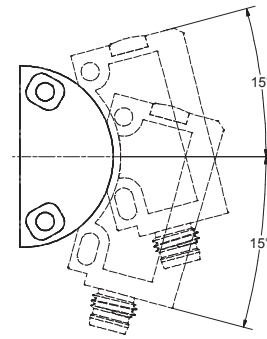

ST-S45-DVT

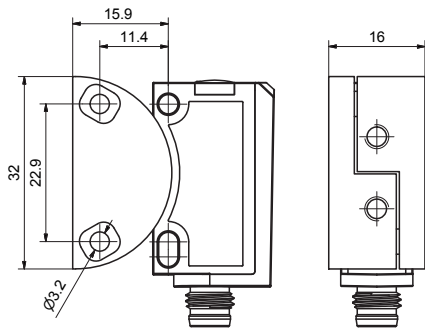

ST-S45-DVT

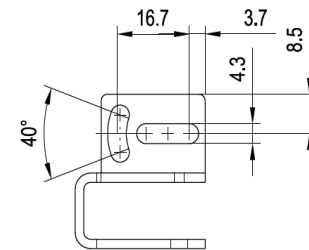
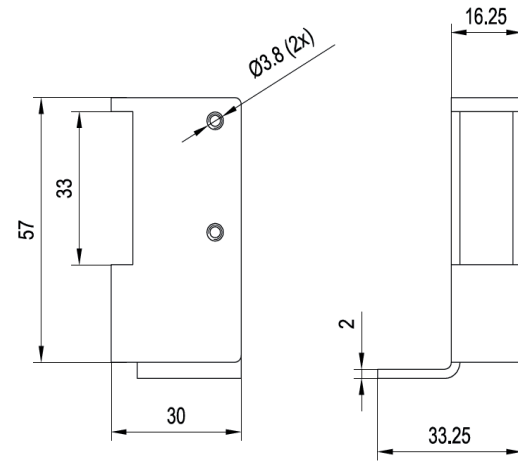

ST-MINI-PRO

MODEL	DESCRIPTION	ORDER NO.
ST-S45-DVT	S45 DOVE TAIL BRACKET	95ACC7970
ST-MINI-PRO	MINI PROTECTIVE BRACKET	95ACC7980

CABLES

TYPE	DESCRIPTION	LENGTH	MODEL	ORDER No.
Axial M8 Connector	4-pole, grey, P.V.C.	3 m	CS-B1-02-G-03	95A251420
		5 m	CS-B1-02-G-05	95A251430
		7 m	CS-B1-02-G-07	95A251440
		10 m	CS-B1-02-G-10	95A251480
	Radial M8 Connector	4-pole, P.U.R.	2 m	CS-B1-02-R-02
5 m			CS-B1-02-R-05	95A251640
4-pole, grey, P.V.C.		3 m	CS-B2-02-G-03	95A251450
		5 m	CS-B2-02-G-05	95A251460
		7 m	CS-B2-02-G-07	95A251470
4-pole, P.U.R.	10 m	CS-B2-02-G-10	95A251530	
	2 m	CS-B2-02-R-02	95A251630	
	5 m	CS-B2-02-R-05	95A251650	

MINIATURE SENSORS

S100

The universal miniature photoelectric sensor

- Two threaded front mounting holes
- Two slotted rear mounting holes
- Anti-tampering sensor (no adjustment)
- Standard optic functions
- M8 connector and cable models
- PNP or NPN models with LIGHT/DARK selection by wire
- Plastic housing, IP67 mechanical protection



APPLICATIONS

- Processing and packaging machines
- Conveyors
- Automatic warehousing
- Intralogistic lines



S100		
Through beam		12 m
Retroreflective		7 m
Polarized Retroreflective (long range)		5,5 m
Polarized Retroreflective (short range)		3 m
Diffused proximity (short range)		300 mm
Diffused proximity (long range)		500 mm
Fixed focus		70 mm
Background suppression		30...100 mm
Power supply	Vdc	10...30 Vdc
Output	PNP	▪
	NPN	▪
Connection	cable	2 m cable, 4 wires
	connector	M8 conn., 4-pole
Approximate dimensions (mm)		32x20x12
Housing material		Plastic
Mechanical protection		IP67

TECHNICAL DATA

Power supply	10 ... 30 Vdc
Ripple	10% max.
Consumption (output current excluded)	20 mA max.
Light emission	red LED 632 nm (mod. S100...B/C/D/M) IR LED 860 nm (mod. S100...A/G)
Setting	remote teach-in (mod. S100...M)
Operating mode	LIGHT/DARK selectable by wire (mod. S100...A/B/C/D/F)
Indicators	yellow OUTPUT LED (excl. mod. G) green POWER LED (mod. S100...G)
Output	PNP or NPN
Output current	100 mA
Saturation voltage	2 V max.
Response time	2 ms (mod. S100...FG) 1 ms (mod. S100...A/B/C/D/M)
Switching frequency	250 Hz (mod. S100...FG) 500 Hz (mod. S100...A/B/C/D/M)
Connection	2 m cable 3,5 mm, M8 4-pole connector
Dielectric strength	500 Vac, 1 min between electronics and housing
Insulating resistance	>20 MΩ, 500 Vdc between electronics and housing
Mechanical protection	IP67
Ambient light rejection	according to EN 60947-5-2
Vibrations	0,5 mm amplitude, 10 ... 55 Hz frequency, for every axis (EN60068-2-6)
Shock resistance	11 ms (30 G) 6 shock for every axis (EN60068-2-27)
Housing material	ABS body, PMMA indicators cover
Lens material	PC lens, PMMA window
Operating temperature	-25... 55 °C
Storage temperature	-40 ... 70 °C
Weight	50 g max. cable vers., 10 g max. connector vers.

DIMENSIONS

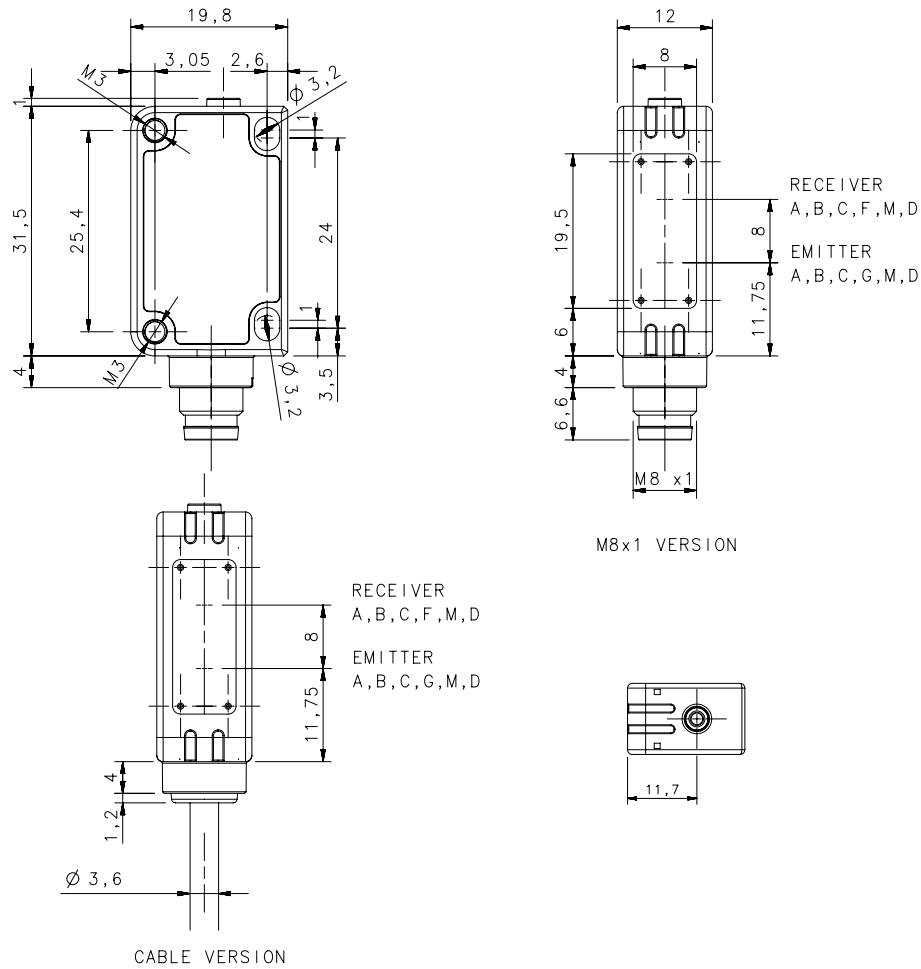

MINIATURE SENSORS

CONNECTIONS

M8 CONNECTOR

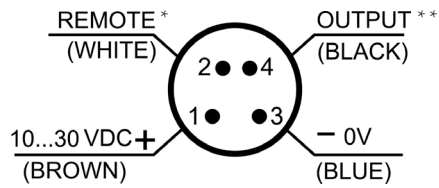

CABLE

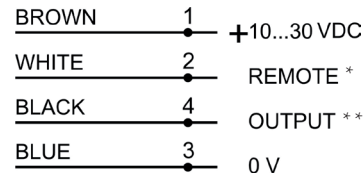

*REMOTE: Light/Dark selection (S100-...-A-B-C-D-F), External Teach-in (S100-...-M)
 **OUTPUT: PNP or NPN depends on the model

INDICATORS AND SETTINGS

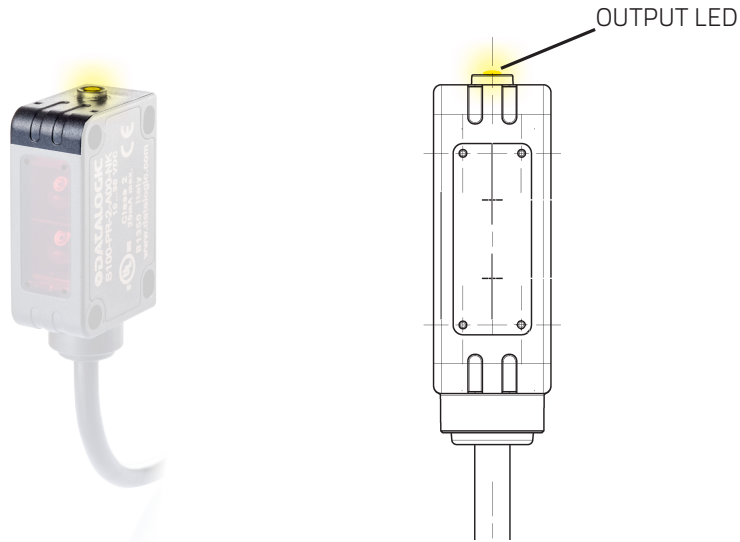

DETECTION DIAGRAMS

THROUGH BEAM

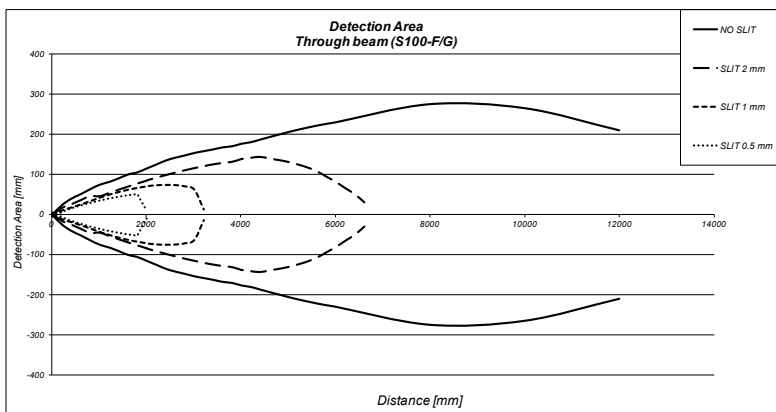

	max. operating distance
NO SLIT	12 m
2 mm SLIT	6,7 m
1 mm SLIT	3,2 m
0,5 mm SLIT	2 m

DIFFUSE PROXIMITY

	SHORT RANGE (S100-...-C0)	LONG RANGE (S100-...-C1)
Recommended operating distance (on White 90% target)	10...240 mm	2...400 mm
Maximum operating distance (White 90% target)	1...300 mm	0...500 mm
Maximum operating distance (Grey 18% target)	20...150 mm	10...280 mm
Maximum operating distance (Black 6% target)	30...80 mm	20...160 mm
Difference White-Grey	50%	50%
Difference White-Black	75%	75%
Hysteresis	20%	20%

DIFFUSE (SHORT RANGE: S100-C00)

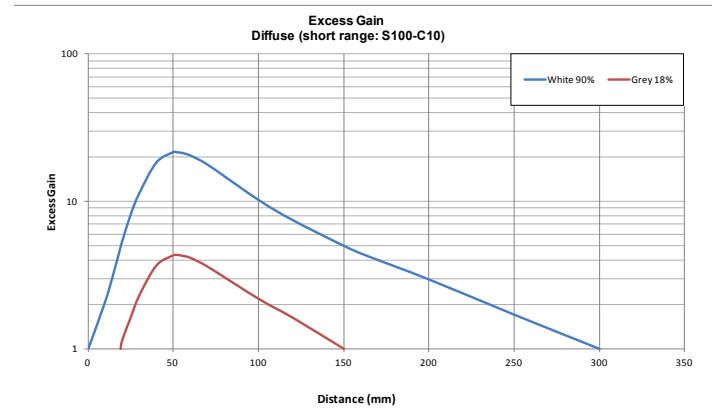
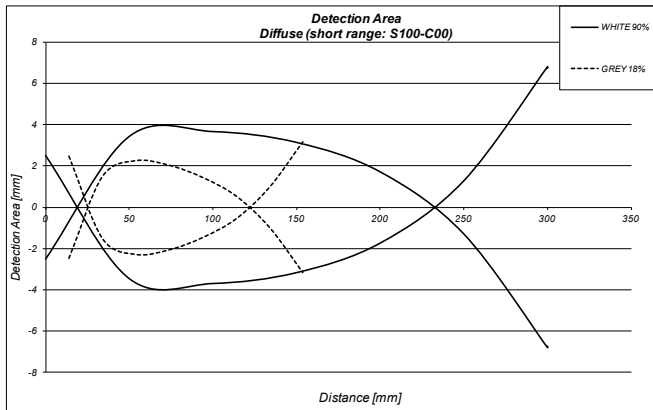

DIFFUSE (LONG RANGE: S100-C10)

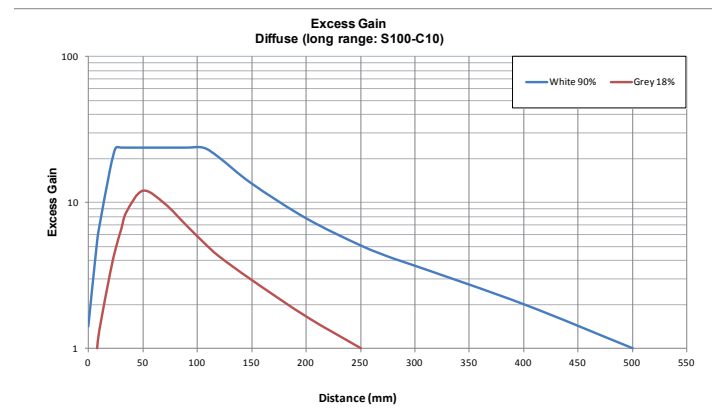
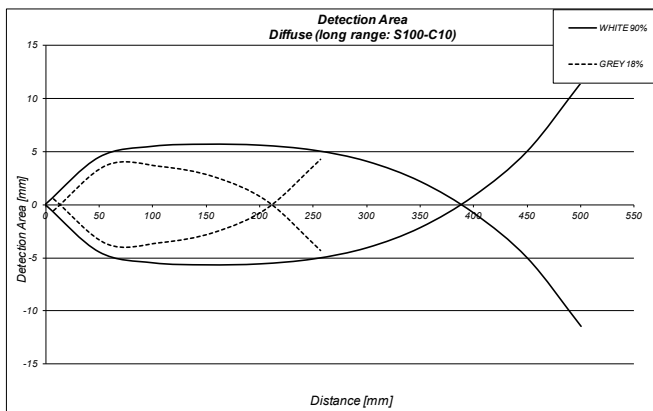

MINIATURE SENSORS

POLARIZED RETROREFLECTIVE

REFLECTOR	TYPE	SHORT RANGE (S100-...-B00)	LONG RANGE (S100-...-B10)
R1	circular (23 mm)	0,2..0,8 m	0,02..2 m
R2	circular (48 mm)	0,03..2 m	0,01..4,5 m
R3	rectangular (18x54 mm)	0,03..1,5 m	0,01..3 m
R4	rectangular (47x47 mm)	0,03..2,5 m	0,01..4,5 m
R5	circular (75 mm)	0,01..3 m	0,01..5,5 m
R6	rectangular (36x55 mm)	0,03..1,8 m	0,01..4 m
RT3970	self-adhesive tape (60x40 mm)	0,2..0,8 m	0,05..1,8 m



	max. operating distance			
	SHORT RANGE (S100-...-B00)		LONG RANGE (S100-...-B10)	
	with R5 reflector	with R2 reflector	with R5 reflector	with R2 reflector
NO SLIT	0,02 ... 3 m	0,02 ... 2 m	0,1...5,5 m	0,01...4,5 m
2 mm SLIT	0,05 ... 1,5 m	0,05 ... 0,8 m	0,2...4 m	0,03...3 m
1 mm SLIT	-	-	0,3...2,5 m	0,05...1,5 m
0,5 mm SLIT	-	-	0,5...1,2 m	0,07...0,7 m

POLARIZED RETROREFLECTIVE (SHORT RANGE: S100-B00)

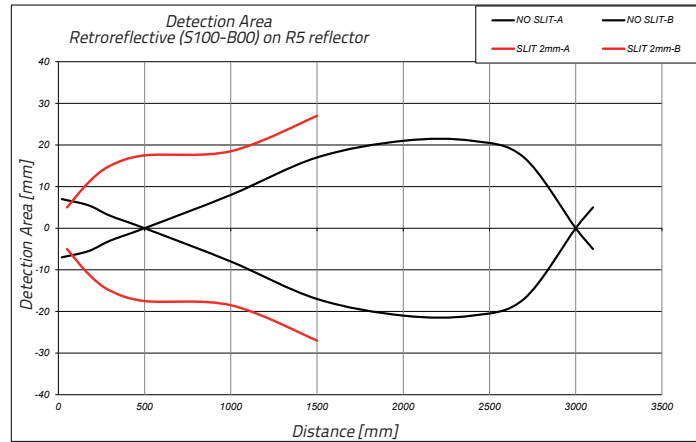
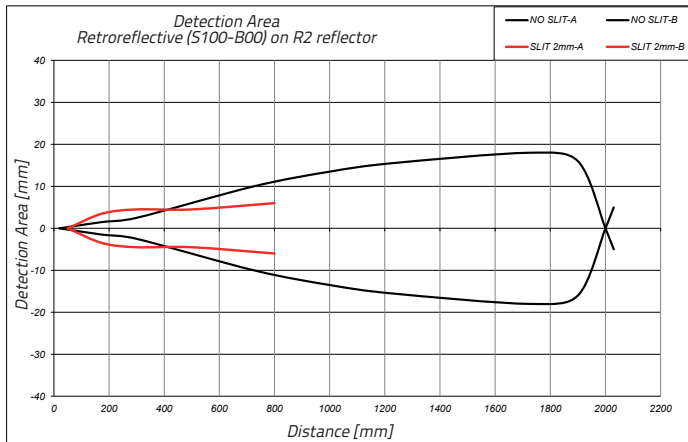

POLARIZED RETROREFLECTIVE (LONG RANGE: S100-B10)

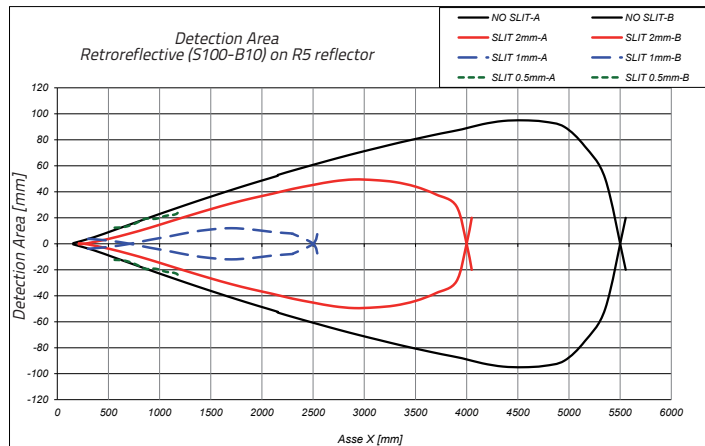
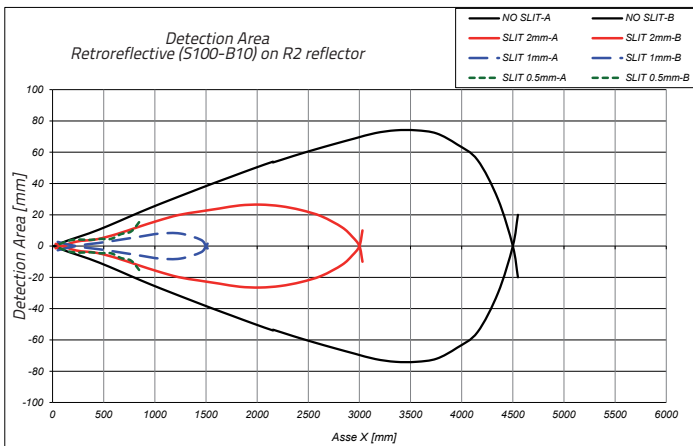

RETROREFLECTIVE (infrared)

REFLECTOR	TYPE	(S100-...-A00)
R1	circular (23 mm)	0.03..3 m
R2	circular (48 mm)	0.01..6 m
R3	rectangular (18x54 mm)	0.01..3.5 m
R4	rectangular (47x47 mm)	0.01..5 m
R5	circular (75 mm)	0.01..7 m
R6	rectangular (36x55 mm)	0.01..6 m
RT3970	self-adhesive tape (60x40 mm)	0.05..2 m



	max. operating distance	
	with R5 reflector	with R2 reflector
NO SLIT	7 m	6 m
2 mm SLIT	4,7 m	3,4 m
1 mm SLIT	2,7 m	2,3 m
0,5 mm SLIT	1,5 m	1 m

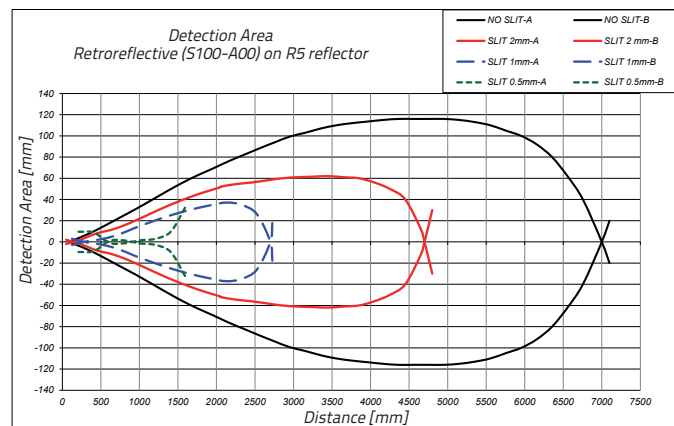
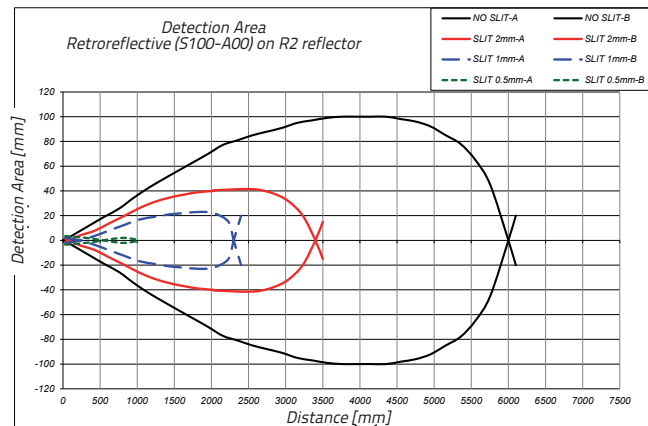

FIXED FOCUS

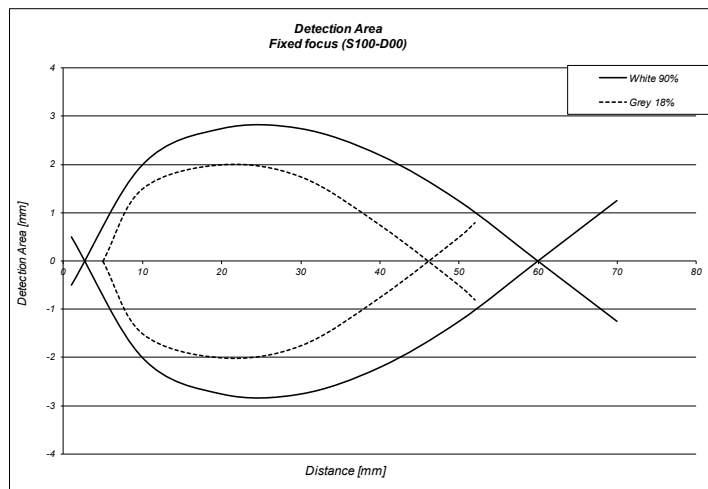

Focus point	70 mm
Maximum operating distance (White 90%)	70 mm
Maximum operating distance (Grey 18%)	55 mm
Difference White/Black	25%

MINIATURE SENSORS

BACKGROUND SUPPRESSION

Operating distances (background suppression)	30...100 mm
Maximum operating distance (White 90%)	0...150 mm
Maximum operating distance (Grey 18%)	4...110 mm
Maximum operating distance (Black 6%)	5...80 mm
Difference White 90%/White 90%	< 5%
Difference White 90%/Grey 18%	< 15%
Difference White 90%/Black 6%	< 25%

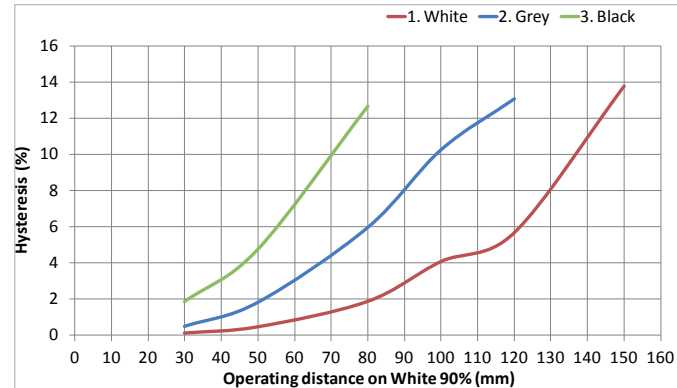
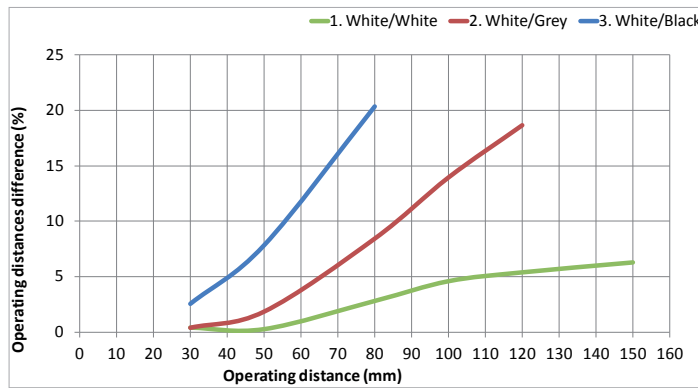

MODEL SELECTION AND ORDER INFORMATION

OPTIC FUNCTION	EMISSION	OPERATING DISTANCE	CONNECTION	OUTPUT	MODEL	ORDER No.
Through beam	IR	12 m	2 m cable	NPN	S100-PR-2-FG00-NK	950811100
			M8 connector	PNP	S100-PR-2-FG00-PK	950811110
Retroreflective	IR	7 m	2 m cable	NPN	S100-PR-5-FG00-NK	950811240
			M8 connector	PNP	S100-PR-5-FG00-PK	950811250
Polarized Retroreflective (short)	RED	2 m	2 m cable	NPN	S100-PR-2-A00-NK	950811000
			M8 connector	PNP	S100-PR-2-A00-PK	950811010
Polarized Retroreflective (long)	RED	5 m	2 m cable	NPN	S100-PR-2-A00-NK	950811140
			M8 connector	PNP	S100-PR-5-A00-PK	950811150
Polarized Retroreflective (long)	RED	5 m	2 m cable	NPN	S100-PR-2-B00-NK	950811020
			M8 connector	PNP	S100-PR-2-B00-PK	950811030
Diffuse proximity (short)	RED	300 mm	2 m cable	NPN	S100-PR-5-B00-NK	950811160
			M8 connector	PNP	S100-PR-5-B00-PK	950811170
Diffuse proximity (long)	RED	500 mm	2 m cable	NPN	S100-PR-2-B10-NK	950811280
			M8 connector	PNP	S100-PR-2-B10-PK	950811290
Fixed focus	RED	70 mm	2 m cable	NPN	S100-PR-5-B10-NK	950811300
			M8 connector	PNP	S100-PR-5-B10-PK	950811310
Background suppression	RED	30...100 mm	2 m cable	NPN	S100-PR-2-C00-NK	950811040
			M8 connector	PNP	S100-PR-2-C00-PK	950811050
Background suppression	RED	30...100 mm	2 m cable	NPN	S100-PR-5-C00-NK	950811180
			M8 connector	PNP	S100-PR-5-C00-PK	950811190
Background suppression	RED	30...100 mm	2 m cable	NPN	S100-PR-2-C10-NK	950811060
			M8 connector	PNP	S100-PR-2-C10-PK	950811070
Background suppression	RED	30...100 mm	2 m cable	NPN	S100-PR-5-C10-NK	950811200
			M8 connector	PNP	S100-PR-5-C10-PK	950811210
Background suppression	RED	30...100 mm	2 m cable	NPN	S100-PR-2-D00-NK	950811080
			M8 connector	PNP	S100-PR-2-D00-PK	950811090
Background suppression	RED	30...100 mm	2 m cable	NPN	S100-PR-5-D00-NK	950811220
			M8 connector	PNP	S100-PR-5-D00-PK	950811230
Background suppression	RED	30...100 mm	2 m cable	NPN	S100-PR-5-M00-NH	950811120
			M8 connector	PNP	S100-PR-2-M00-PH	950811130
Background suppression	RED	30...100 mm	2 m cable	NPN	S100-PR-5-M00-NH	950811260
			M8 connector	PNP	S100-PR-5-M00-PH	950811270

ACCESSORIES

ST-5039

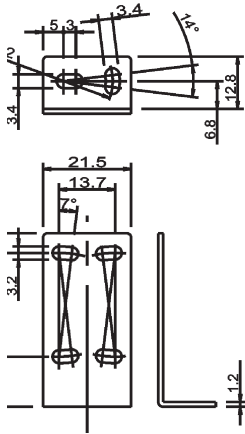

ST-505

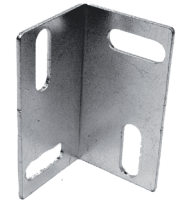
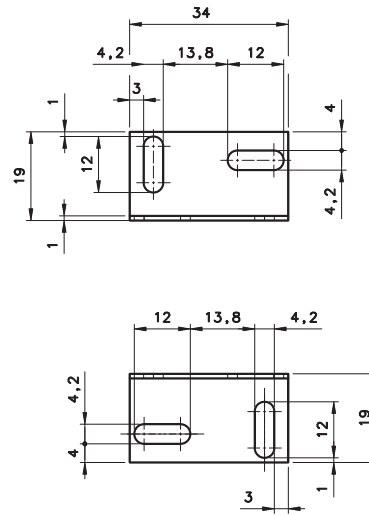

M18 ADAPTER NOSE



SLIT

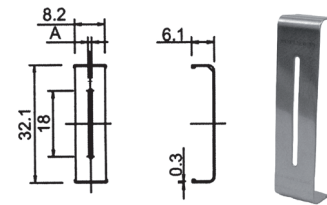

TYPE	MODEL	DESCRIPTION	Order No.
Mounting bracket	ST-505	lateral mounting	95ACC2800
	ST-5039	L-shaped bracket	95ACC2270
Slit	S100-SLIT-05	0,5x19 mm SLIT	95ACC3450
	S100-SLIT-1	1x19 mm SLIT	95ACC3460
	S100-SLIT-2	2x19 mm SLIT	95ACC3470
M18 adapter	ST-S3Z-M18	M18 THREADED ADAPTER NOSE	95ACC7850

CABLES

TYPE	DESCRIPTION	LENGTH	MODEL	ORDER No.
Axial M8 Connector	4-pole, grey, P.V.C.	3 m	CS-B1-02-G-03	95A251420
		5 m	CS-B1-02-G-05	95A251430
		7 m	CS-B1-02-G-07	95A251440
		10 m	CS-B1-02-G-10	95A251480
	4-pole, P.U.R.	2 m	CS-B1-02-R-02	95A251620
		5 m	CS-B1-02-R-05	95A251640
Radial M8 Connector	4-pole, grey, P.V.C.	3 m	CS-B2-02-G-03	95A251450
		5 m	CS-B2-02-G-05	95A251460
		7 m	CS-B2-02-G-07	95A251470
		10 m	CS-B2-02-G-10	95A251530
	4-pole, P.U.R.	2 m	CS-B2-02-R-02	95A251630
		5 m	CS-B2-02-R-05	95A251650

COMPACT SENSORS

S8

Compact size and high performance for the most challenging detection applications

- Compact dimensions (14x42x25 mm)
- Background suppression for transparent and shiny objects
- Contrast sensors up to 10 kHz switching frequency
- Extremely focused spot, under 1 mm (LASER model)
- Very high resolution LASER models
- INOX AISI 316L model

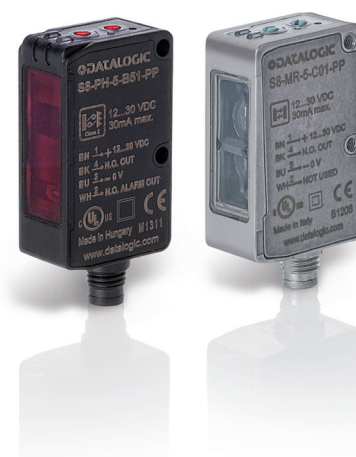

APPLICATIONS

- Processing and Packaging machinery
- Beverage/Food/ Cosmetics/ Pharmaceutical industries
- Electronics assembling



(*) Stainless steel models.
ATEX II 3DG

S8		
Through beam		0...25 m
Polarized retroreflective		0,1...5 m
Retroreflective for transparent (coaxial)		0...10 m (class 2 LASER)
Diffuse proximity		0...0,8 m (T51), 0...2 m (T53, T50)
Background suppression		0...500 mm
Background suppression for clear detection		50...300 mm
Contrast sensor		20...200 mm (class 2 LASER)
Luminescence sensor		100...300 mm (LED)
		50...150 mm (class 2 LASER)
Power supply	Vdc	10 mm
	Vac	10...30 mm
	Vac/dc	10...30 V
Output	PNP	▪
	NPN	▪
	NPN/PNP	
	relay	
	other	
Connection	cable	▪
	connector	▪
	pig-tail	▪
Approximate dimensions (mm)		14x42x25
Housing material		ABS, Stainless Steel AISI 316L
Mechanical protection		IP69K (Stainless Steel vers.), IP67

TECHNICAL DATA

Power supply	12 ... 30 Vdc (short-circuit protection)
Ripple	2 Vpp max.
Consumption (output current excluded)	30 mA; 35 mA (mod. S8...M01); 20 mA (mod. S8...F), 15 mA (mod. S8...G) max.
Light emission	red LED 660 nm (mod. S8...B/C/M/G/T) RGB LEDs: blue 465 nm, green 520 nm, red 630nm with automatic selection (mod. S8...W) UV LED 375 nm (mod. S8...U) red Laser 645..665 nm (mod. S8...B/M)
Setting	8-turn distance adjustment trimmer (mod. S8...M53/M) LIGHT / DARK mono-turn trimmer (mod. S8...B/C/F/T51) teach-in push button (mod. S8...M53/W03/W13/T53/U) remote input (mod. S8...W/U/T50/T53)
Operating mode	mono-turn trimmer (mod. S8...B/C/F/M/T/U/W13) automatic (mod. S8...W/T50) remote input (mod. S8...M53)
Indicators	yellow OUTPUT LED (excl. mod. S8...G), OUTPUT/ALARM LED (mod. S8...M53/M/C) green POWER LED
Output	PNP or NPN N.O.
Output current	100 mA (overload protection)
Saturation voltage	2 V max.
Response time	1 ms (mod. S8...M53/M) 500 µs (mod. S8...B/F/C) 250 µs (mod. S8...T) 100 µs (Laser vers. mod. S8...M) 50 µs (mod. S8...W00/W03 e Laser mod. S8...B) 20 µs (mod. S8...W13) 250 µs...1 ms (mod. S8...U)
Switching frequency	500 Hz (mod. S8...M53/M) 1 kHz (mod. S8...B/F/C) 2 kHz (mod. S8...T) 5 kHz (Laser vers. mod. S8...M) 10 kHz (mod. S8...W00/W03 e Laser mod. S8...B) 25 kHz (mod. S8...W13) 500 Hz...2 kHz (mod. S8...U)
Connection	M8 4-pole connector, 150 mm length Ø 4 mm cable with M12 4-pole connector (pig-tail vers.)
Dielectric strength	1500 VAC 1 min between electronic parts and housing
Insulating resistance	>20 MΩ 500 VDC between electronic parts and housing
Mechanical protection	IP67, IP69K (mod. S8-M)
Ambient light rejection	according to EN 60947-5-2
Vibrations	0.5 mm amplitude, 10 ... 55 Hz frequency, for every axis (EN60068-2-6)
Shock resistance	11 ms (30 G) 6 shocks per every axis (EN60068-2-27)
Housing material	ABS, Stainless Steel AISI346L
Lens material	window in PMMA; lens in PC
Operating temperature	-10 ... 55 °C
Storage temperature	-20 ... 70 °C
Weight	12 g max. conn. vers., 50 g pig-tail vers., 70 g max. (mod. S8-M)

CONNECTIONS

M12 PIGTAIL

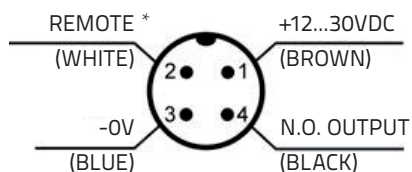

M8 CONNECTOR

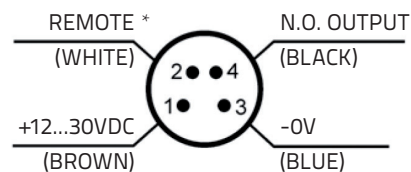

* REMOTE INPUT (mod. S8...W, U, T50, T53), LIGHT / DARK INPUT (mod. S8...M53), DELAY (mod. S8...M Laser), TEST INPUT (mod. S8...G), ALARM OUTPUT (mod. S8...B, T51), NOT USED (mod. S8...C, M, F)

COMPACT SENSORS

DIMENSIONS

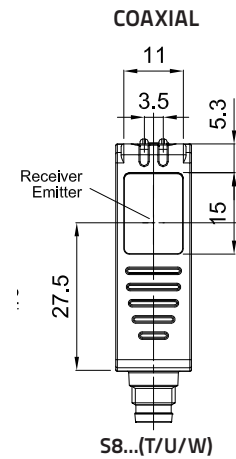
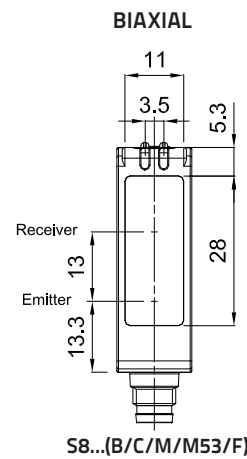
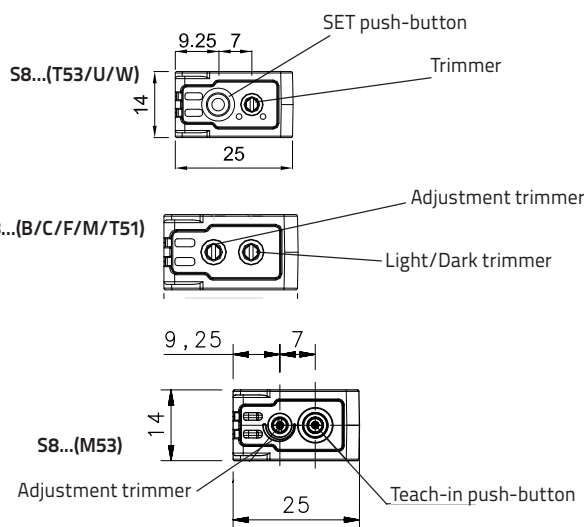
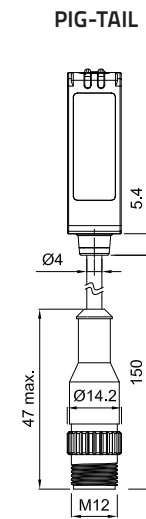
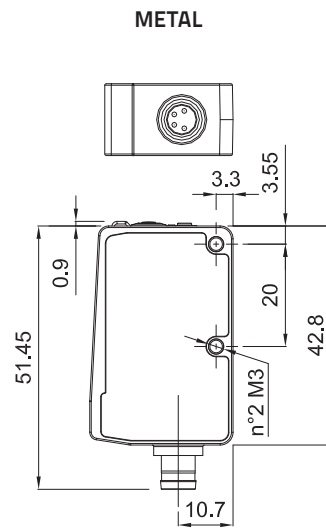
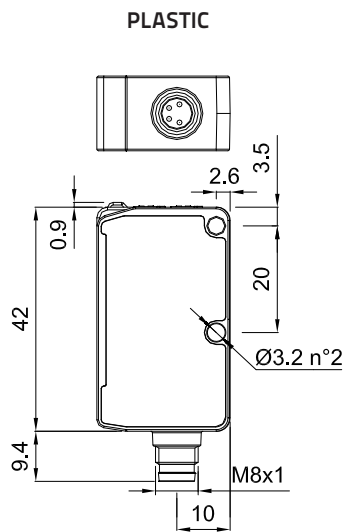

INDICATOR AND SETTING

S8...M / B / C / T01

S8...W / T53

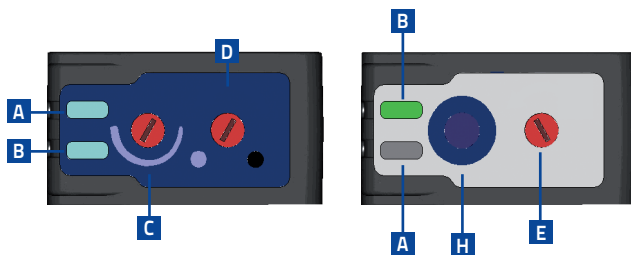

- A Output status LED
- B Ready LED or Power ON LED
- C Sensitivity adjustment trimmer
- D Dark/light trimmer

- E Delay trimmer
- F M8 connector
- G M12 pig-tail connector
- H SET push-button

READING DIAGRAMS

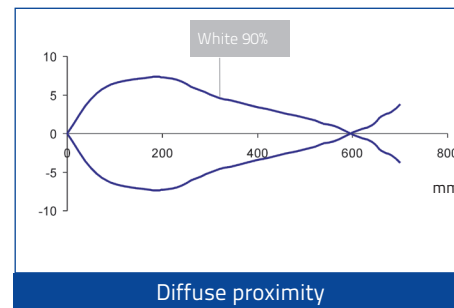
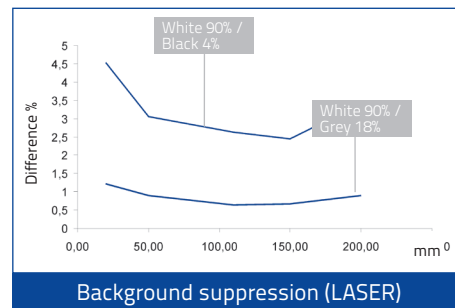
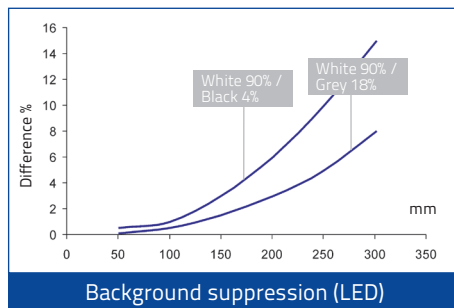
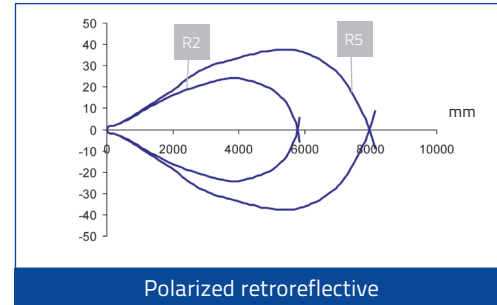
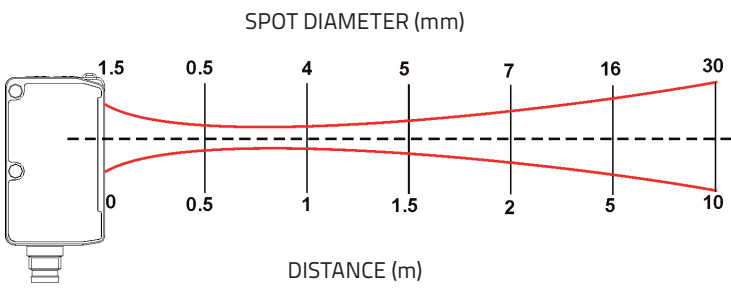
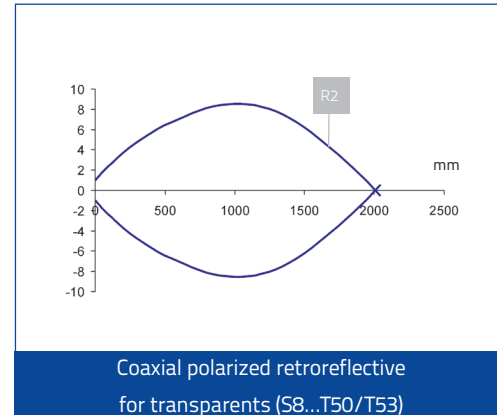
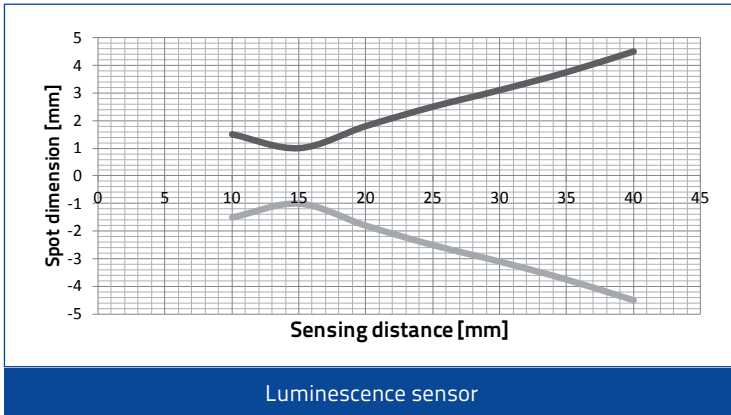
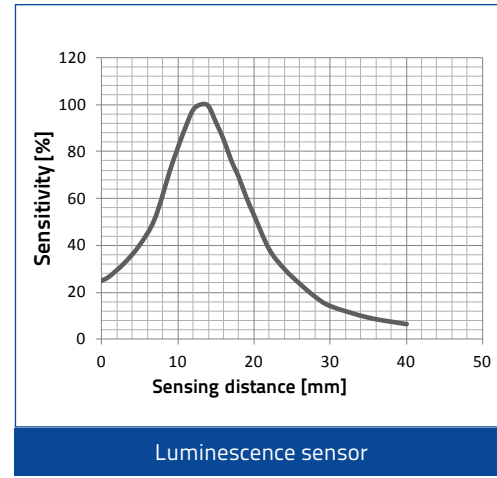
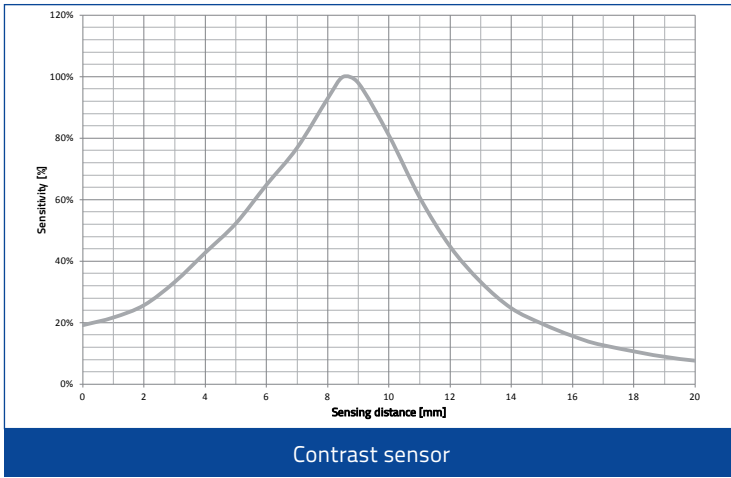

COMPACT SENSORS

MODEL SELECTION AND ORDER INFORMATION

CLEAR DETECTION					
HOUSING	LIGHT EMISSION	CONNECTION	OUTPUT	MODEL	ORDER NO.
METAL Stainless Steel (INOX AISI346L)	LASER	M8 connector	PNP	S8-MH-5-M53-PP	950801450
	LED			S8-MR-5-M53-PP	950801600
PLASTIC ABS	LASER			S8-PH-5-M53-PP	950801380
	LED			S8-PR-5-M53-PP	950801590

RETROREFLECTIVE FOR TRASPARENT					
HOUSING	LIGHT EMISSION	CONNECTION	OUTPUT	MODEL	ORDER NO.
METAL Stainless Steel (INOX AISI346L)	LED	M8 connector	NPN	S8-MR-5-T50-NH	950801330
			PNP	S8-MR-5-T50-PH	950801320
		M8 connector with auto-adjustment function	NPN	S8-MR-5-T53-NN	950801310
			PNP	S8-MR-5-T53-PP	950801300
PLASTIC ABS		pig-tail	NPN	S8-PR-3-T51-NN	950801130
			PNP	S8-PR-3-T51-PP	950801120
		M8 connector	NPN	S8-PR-5-T51-NN	950801050
			PNP	S8-PR-5-T51-PP	950801040
M8 connector with auto-adjustment function	NPN	S8-PR-5-T53-NN	950801290		
	PNP	S8-PR-5-T53-PP	950801280		

POLARIZED RETROREFLECTIVE					
HOUSING	LIGHT EMISSION	CONNECTION	OUTPUT	MODEL	ORDER NO.
METAL Stainless Steel (INOX AISI346L)	LASER	M8 connector	NPN	S8-MH-5-B51-NN	950801490
			PNP	S8-MH-5-B51-PP	950801480
	LED		NPN	S8-MR-5-B01-NN	950801420
			PNP	S8-MR-5-B01-PP	950801410
PLASTIC ABS	LASER	pig-tail	NPN	S8-PH-3-B51-NN	950801090
			PNP	S8-PH-3-B51-PP	950801080
		M8 connector	NPN	S8-PH-5-B51-NN	950801010
			PNP	S8-PH-5-B51-PP	950801000
	LED	pig-tail	NPN	S8-PR-3-B01-NN	950801190
			PNP	S8-PR-3-B01-PP	950801180
		M8 connector	NPN	S8-PR-5-B01-NN	950801170
			PNP	S8-PR-5-B01-PP	950801160

BACKGROUND SUPPRESSION					
HOUSING	LIGHT EMISSION	CONNECTION	OUTPUT	MODEL	ORDER NO.
METAL Stainless Steel (INOX AISI346L)	LASER	M8 connector	NPN	S8-MH-5-M01-NN	950801470
			PNP	S8-MH-5-M01-PP	950801460
	LED		NPN	S8-MR-5-M01-NN	950801400
			PNP	S8-MR-5-M01-PP	950801390
PLASTIC ABS	LASER	pig-tail	NPN	S8-PH-3-M01-NN	950801110
			PNP	S8-PH-3-M01-PP	950801100
		M8 connector	NPN	S8-PH-5-M01-NN	950801030
			PNP	S8-PH-5-M01-PP	950801020
	LED	pig-tail	NPN	S8-PR-3-M01-NN	950801230
			PNP	S8-PR-3-M01-PP	950801220
		M8 connector	NPN	S8-PR-5-M01-NN	950801210
			PNP	S8-PR-5-M01-PP	950801200



THROUGH BEAM					
HOUSING	LIGHT EMISSION	CONNECTION	OUTPUT	MODEL	ORDER NO.
METAL Stainless Steel (INOX AISI316L)	LED	M8 connector	NPN	S8-MR-5-F01-NN	950801570
			PNP	S8-MR-5-F01-PP	950801560
			emitter	S8-MR-5-G00-XG	950801580
PLASTIC ABS		pig-tail	NPN	S8-PR-3-F01-NN	950801530
			PNP	S8-PR-3-F01-PP	950801520
			emitter	S8-PR-3-G00-XG	950801550
M8 connector		NPN	S8-PR-5-F01-NN	950801510	
		PNP	S8-PR-5-F01-PP	950801500	
		emitter	S8-PR-5-G00-XG	950801540	

DIFFUSE					
HOUSING	LIGHT EMISSION	CONNECTION	OUTPUT	MODEL	ORDER NO.
METAL Stainless Steel (INOX AISI316L)	LED	M8 connector	NPN	S8-MR-5-C01-NN	950801440
			PNP	S8-MR-5-C01-PP	950801430
			emitter	S8-MR-5-G00-XG	950801450
PLASTIC ABS		pig-tail	NPN	S8-PR-3-C01-NN	950801270
			PNP	S8-PR-3-C01-PP	950801250
			emitter	S8-PR-3-G00-XG	950801280
M8 connector	NPN	S8-PR-5-C01-NN	950801260		
	PNP	S8-PR-5-C01-PP	950801240		
	emitter	S8-PR-5-G00-XG	950801290		

CONTRAST					
SWITCHING FREQUENCY	HOUSING	CONNECTION	OUTPUT	MODEL	ORDER NO.
10 kHz	METAL Stainless Steel	M8 connector without trimmer	PNP	S8-MR-5-W00-PH	950801360
			NPN	S8-MR-5-W00-NH	950801370
			emitter	S8-MR-5-G00-XG	950801380
		M8 connector	PNP	S8-MR-5-W03-PP	950801340
			NPN	S8-MR-5-W03-NN	950801350
			emitter	S8-MR-5-G00-XG	950801390
	PLASTIC ABS	M12 pig-tail (150 mm)	PNP	S8-PR-3-W03-PP	950801140
			NPN	S8-PR-3-W03-NN	950801150
			emitter	S8-PR-3-G00-XG	950801160
25 kHz	METAL Stainless Steel	M8 connector	PNP	S8-PR-5-W03-PP	950801060
			NPN	S8-PR-5-W03-NN	950801070
			emitter	S8-PR-5-G00-XG	950801080
		M8 connector	PNP	S8-MR-5-W13-PP	950801670
			NPN	S8-MR-5-W13-NN	950801680
			emitter	S8-MR-5-G00-XG	950801690
	PLASTIC ABS	M12 pig-tail (150 mm)	PNP	S8-PR-5-W13-PP	950801650
			NPN	S8-PR-5-W13-NN	950801660
			emitter	S8-PR-5-G00-XG	950801700
M8 connector	PNP	S8-PR-3-W13-PP	950801690		
	NPN	S8-PR-3-W13-NN	950801700		
	emitter	S8-PR-3-G00-XG	950801710		

LUMINESCENCE					
HOUSING	SETTINGS	CONNECTION	OUTPUT	MODEL	ORDER NO.
METAL Stainless Steel	Teach-in push-button; L/D trimmer selector; Remote input	M8 connector	PNP	S8-MR-5-U03-PP	950801630
			NPN	S8-MR-5-U03-NN	950801640
			emitter	S8-MR-5-G00-XG	950801650
PLASTIC ABS		pig-tail	PNP	S8-PR-5-U03-PP	950801610
			NPN	S8-PR-5-U03-NN	950801620
			emitter	S8-PR-5-G00-XG	950801660
M8 connector	PNP	S8-PR-3-U03-PP	950801710		
	NPN	S8-PR-3-U03-NN	950801720		
	emitter	S8-PR-3-G00-XG	950801730		

COMPACT SENSORS

ACCESSORIES

ST-S8-S3Z

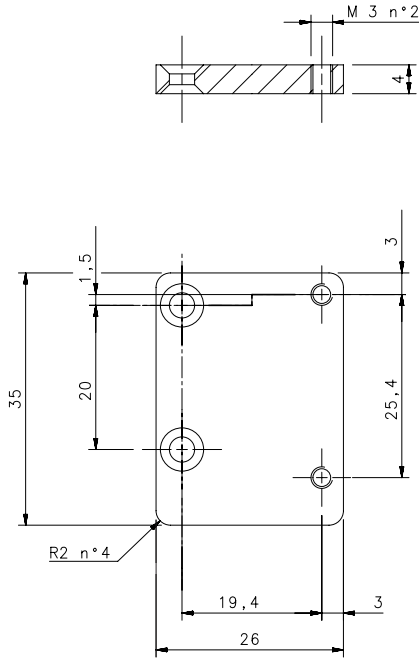

ST-S8-TL-LD46

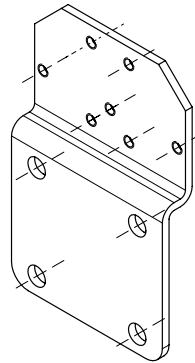
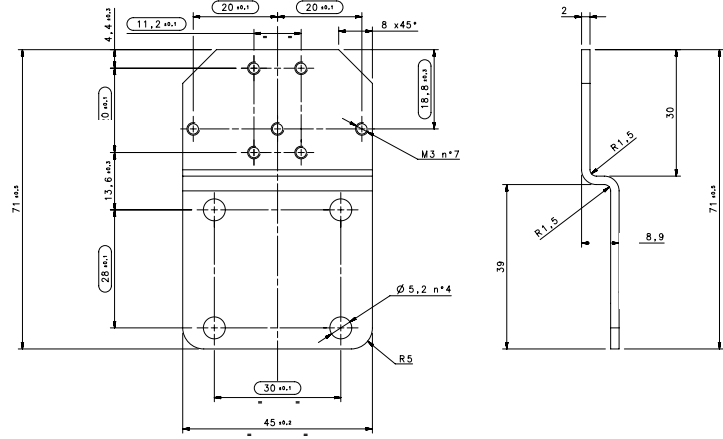

ST-S8-FRM

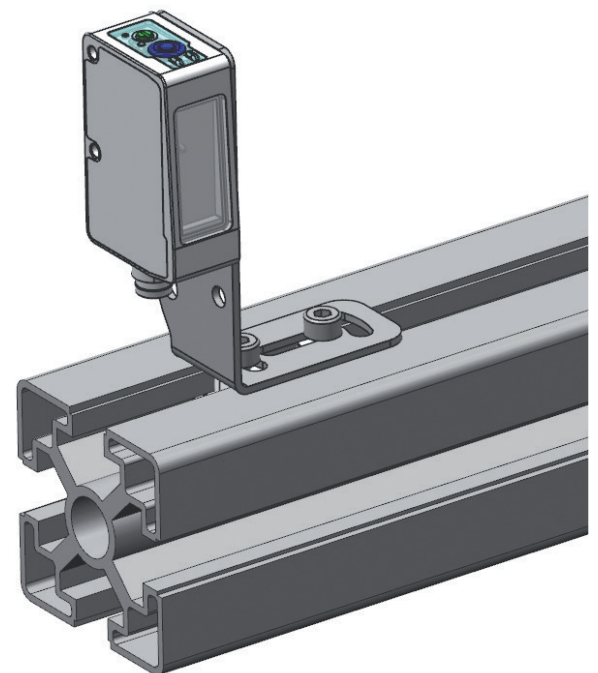
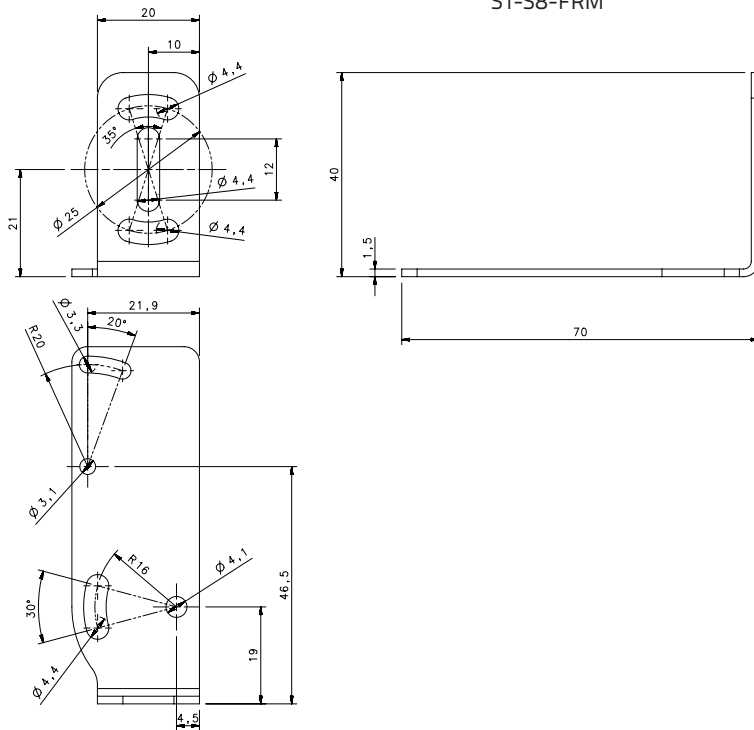

ST-5072

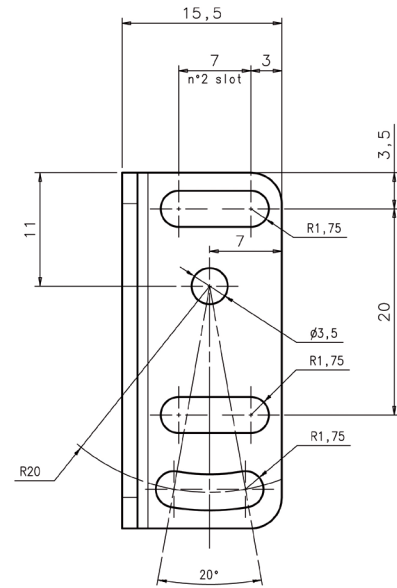
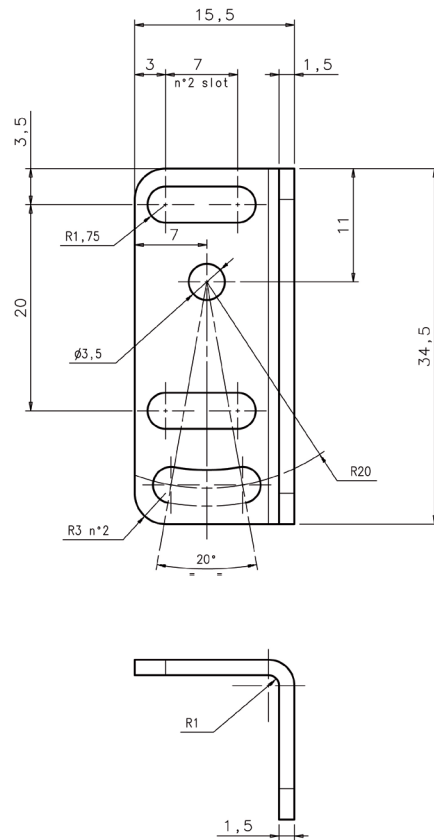
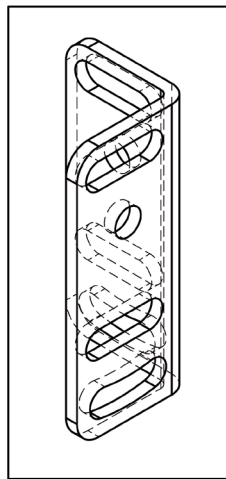

MODEL	FUNCTION	ORDER No.
ST-S8-FRM	mounting bracket for standard frame	95ACC7860
ST-5072	mounting bracket	95ACC1470
R4K	IP69K plastic reflector 51 x 61 mm	95A151220
ST-S8-TL-LD46	TL-LD46 adapting bracket	95ACC3430
ST-S8-S3Z	S8-miniature sensors adapting bracket	95ACC3440

CABLES

TYPE	DESCRIPTION	LENGTH	MODEL	ORDER No.
Axial M8 Connector	4-pole, grey, P.V.C.	3 m	CS-B1-02-G-03	95A251420
		5 m	CS-B1-02-G-05	95A251430
		7 m	CS-B1-02-G-07	95A251440
		10 m	CS-B1-02-G-10	95A251480
	4-pole, P.U.R.	2 m	CS-B1-02-R-02	95A251620
		5 m	CS-B1-02-R-05	95A251640
Radial M8 Connector	4-pole, grey, P.V.C.	3 m	CS-B2-02-G-03	95A251450
		5 m	CS-B2-02-G-05	95A251460
		7 m	CS-B2-02-G-07	95A251470
		10 m	CS-B2-02-G-10	95A251530
	4-pole, P.U.R.	2 m	CS-B2-02-R-02	95A251630
		5 m	CS-B2-02-R-05	95A251650

COMPACT SENSORS

S6

Multivoltage 50x50 mm compact sensors series

- 50x50 mm compact dimensions
- Free voltage Vac/Vdc models with relay output
- 10-30 Vdc model with transistor output
- Standard cable or M12 4-pole connection



APPLICATIONS

- Automatic machines
- Packaging lines
- Transportation lines
- Automatic warehouses



S6		
Through beam		0...20 m
Retroreflective (on R2 reflector)		0,1...6 m
Polarized retroreflective (on R2 reflector)		0,1...5 m
Diffuse proximity		10...900 mm
		10...2000 mm
Background suppression		30...100 mm
		30...250 mm
		100...500 mm
Power supply	Vdc	10...30 V
	Vac	
	Vac/dc	15...264 Vac/Vdc
Output	PNP	▪
	NPN	▪
	NPN/PNP	▪
	relay	▪
	other	
Connection	cable	▪
	connector	▪
	pig-tail	
Approximate dimensions (mm)		18x50x50
Housing material		ABS
Mechanical protection		IP65

TECHNICAL DATA

Power supply	10 ... 30 Vdc limit values (mod. S6/S6T/S6R-5) 15 ... 264 Vac/Vdc (48 ... 60 Hz) limit values (mod. S6-1)
Ripple	2 Vpp max.
Consumption (output current excluded)	30 mA max. (mod. S6/S6T/S6R-5) 40 mA max. (mod. S6-1)
Light emission	IR LED 880 nm red LED 660 nm (mod. S6/S6R/S6T...B/M10)
Setting	sensitivity trimmer (excl. mod. S6...G, S6R-5-M) adjustment screw (mod. S6/S6T/S6R-5-M)
Operating mode	LIGHT/DARK selection by cable or connector (mod. S6/S6T/S6R-5) LIGHT/DARK selection by N.O./N.C. output (mod. S6R-5-M) LIGHT/DARK selection by trimmer (mod. S6-1)
Indicators	red OUTPUT LED (excl. mod. S6...G), POWER LED (mod. S6...G) green STABILITY LED (mod. S6-5-M25)
Output	NPN/PNP (mod. S6) PNP (mod. S6T) NPN or PNP; NC; NO (mod. S6R) Relay 1 NO and NC contact 250 Vac, 30 Vdc min. applicable load 5 Vdc, 10 mA (mod. S6-1)
Output current	100 mA max., 3 A max. (mod. S6-1)
Saturation voltage	1,5 V max. (NPN/PNP output) 1 ms max.
Response time	2 ms max. (mod. S6/S6R/S6T...F/G) 30 ms max. (mod. S6-1) 500 Hz
Switching frequency	250 Hz max. (mod. S6/S6R/S6T...F/G) 16 Hz (mod. S6-1)
Connection	2 m cable Ø 6 mm (mod. S6-1), 2 m cable Ø 5 mm (mod. S6-5), M12 4-pole connector (mod. S6T-S6R)
Dielectric strength	500 Vac, 1 min between electronics and housing
Insulating resistance	>20 MΩ, 500 Vdc between electronics and housing
Electrical protection	class 2, class 1 (mod. S6-1)
Mechanical protection	IP65
Ambient light rejection	according to EN 60947-5-2
Vibrations	0,5 mm amplitude, 10 ... 55 Hz frequency, for every axis (EN60068-2-6)
Shock resistance	11 ms (30 G) 6 shock for every axis (EN60068-2-27)
Housing material	ABS UL 94V-0
Lens material	PMMA plastic
Operating temperature	-25 ... 55 °C
Storage temperature	-25 ... 70 °C
Weight	160 g max. cable vers., 40 g max. conn. vers.

DIMENSIONS

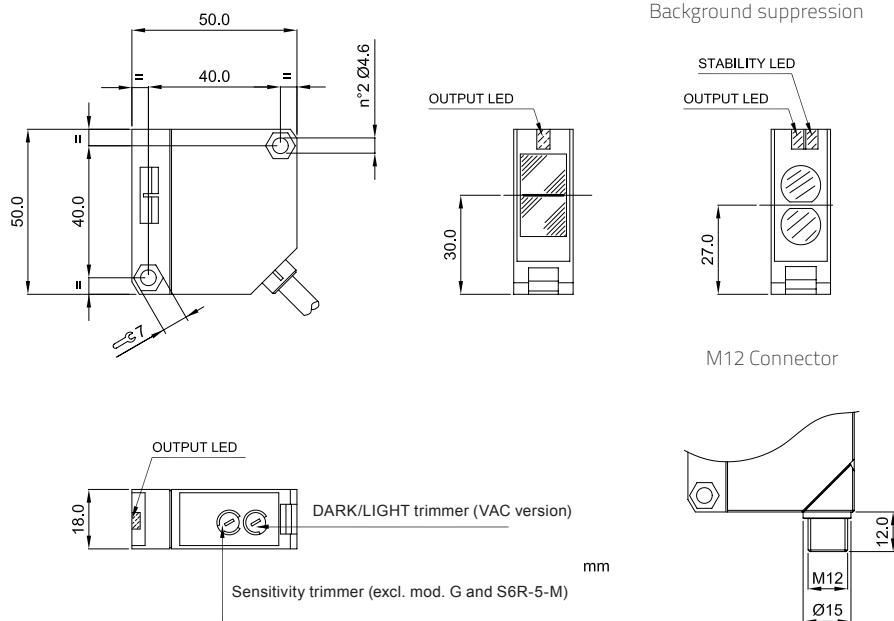

COMPACT SENSORS

CONNECTIONS

VDC MODELS

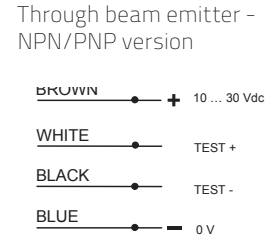
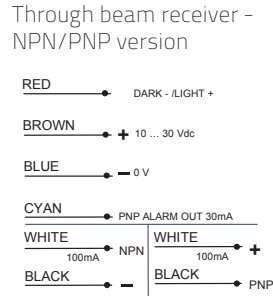
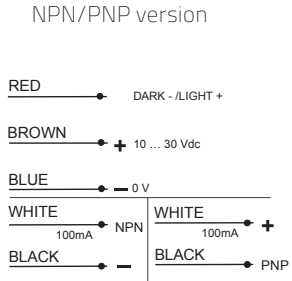

NPN or PNP and NC/NO version

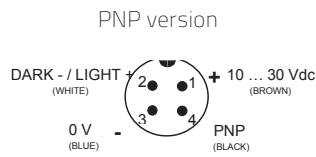
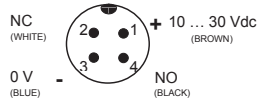

Through beam emitter - PNP version

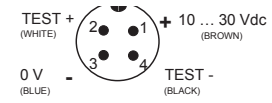

VAC MODELS

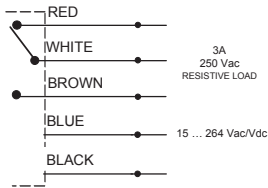

Through beam emitter



INDICATORS AND SETTINGS



Background suppression

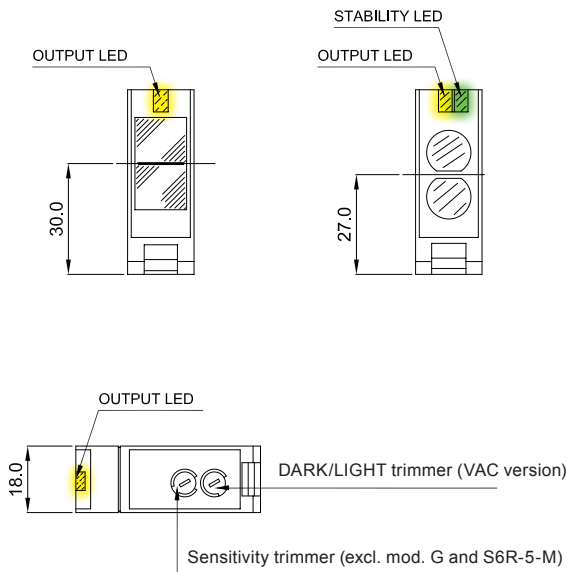

DETECTION DIAGRAMS

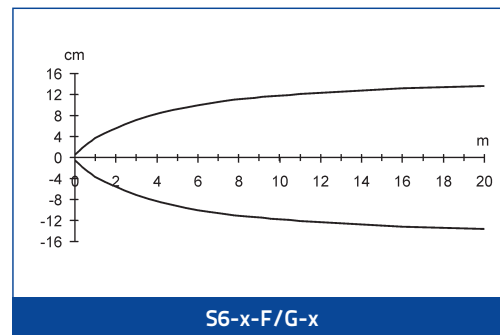
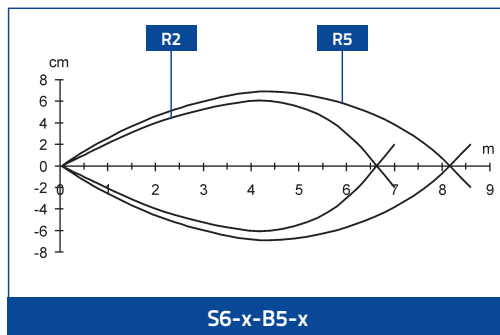
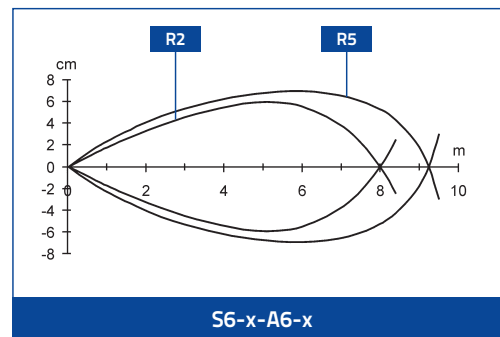
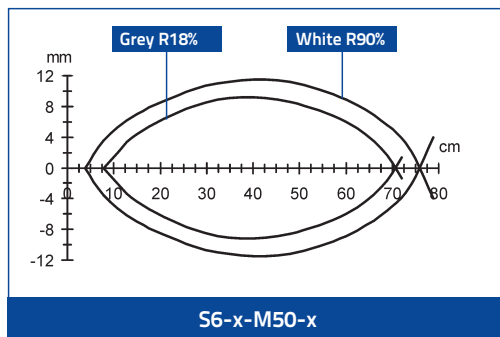
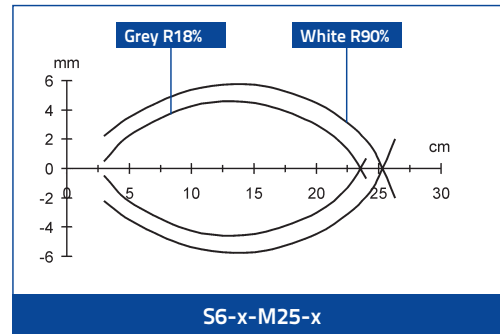
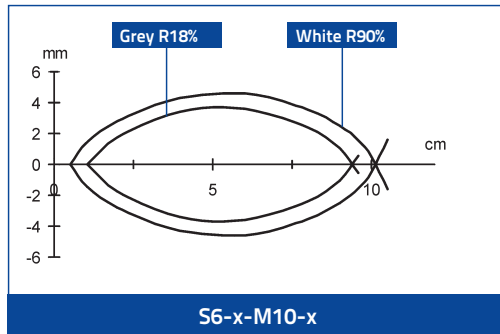
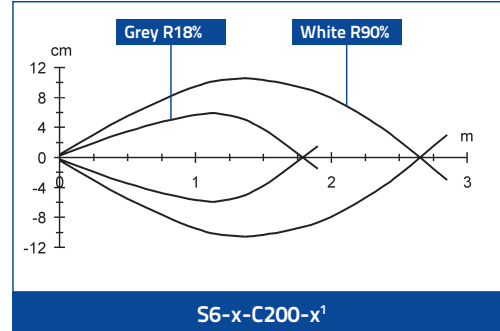
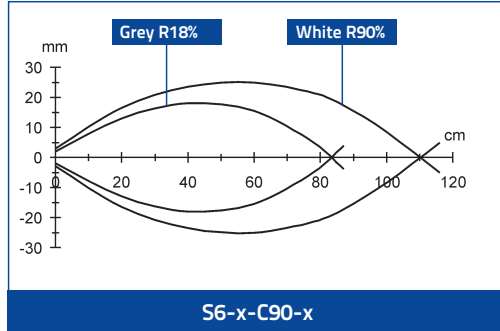

The detection diagrams indicate the typical operating distance with excess gain 1.

COMPACT SENSORS

MODEL SELECTION AND ORDER INFORMATION

OPTIC FUNCTION	OPERATING	POWER SUPPLY	OUTPUT	MODEL	ORDER No.
Short diffuse proximity	10...900 mm	15...264 V A.C.	relay SPDT 250V/3A	S6-1-C90	5937530090
			NPN / PNP	S6-5-C90	5937530000
		10...30 V D.C.	PNP N.O./N.C.	S6R-5-C90-P	950201190
			PNP	S6T-5-C90-P	961031020
Long diffuse proximity	10...2000 mm	15...264 V A.C.	relay SPDT 250V/3A	S6-1-C200	950151140
			NPN / PNP	S6-5-C200	950201150
		10...30 V D.C.	PNP N.O./N.C.	S6R-5-C200-P	950201200
			NPN N.O./N.C.	S6R-5-C200-N	956101050
Retroreflective	0,1...6 m (on R2 reflector)	15...264 V A.C.	relay SPDT 250V/3A	S6-1-A6	5937330090
			NPN / PNP	S6-5-A6	5937330000
		10...30 V D.C.	PNP	S6T-5-A6-P	961031000
			PNP N.O./N.C.	S6R-5-A6-P	950201170
Polarized retroreflective	0,1...5 m (on R2 reflector)	15...264 V A.C.	relay SPDT 250V/3A	S6-1-B5	5937420090
			NPN / PNP	S6-5-B5	5937420000
		10...30 V D.C.	PNP N.O./N.C.	S6R-5-B5-P	950201180
			PNP	S6T-5-B5-P	961031010
Background suppression	30...100 mm	10...30 V D.C.	PNP N.O./N.C.	S6R-5-M10-P	950201230
	30...250 mm		NPN / PNP	S6-5-M25	5937830000
			PNP N.O./N.C.	S6R-5-M25-P	950201220
			NPN N.O./N.C.	S6R-5-M25-N	956101080
	100...500 mm		PNP	S6T-5-M25-P	961041000
			PNP N.O./N.C.	S6R-5-M50-P	950201250
Through beam (Receiver)	0...20 m	15...264 V A.C.	relay SPDT 250V/3A	S6-1-F20	5937200090
			NPN / PNP	S6-5-F20	5937200010
		10...30 V D.C.	PNP N.O./N.C.	S6R-5-F20-P	950201160
			PNP	S6T-5-F20-P	961211010
Through beam (Emitter)	-	15...264 V A.C.	-	S6-1-G20	5937130090
		10...30 V D.C.	-	S6-5-G20	5937130000
			-	S6T-5-G20	961211000

ACCESSORIES

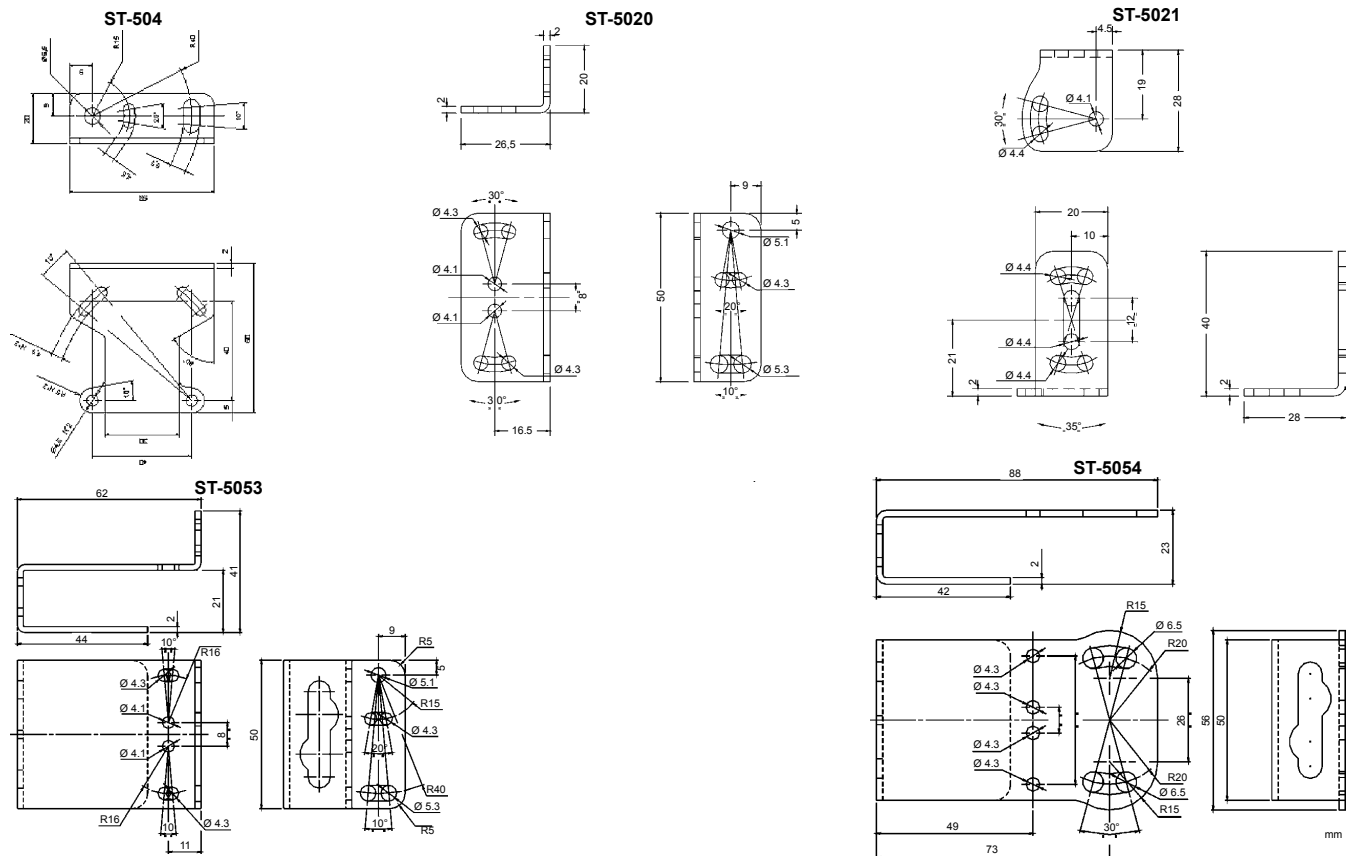

ST-5018

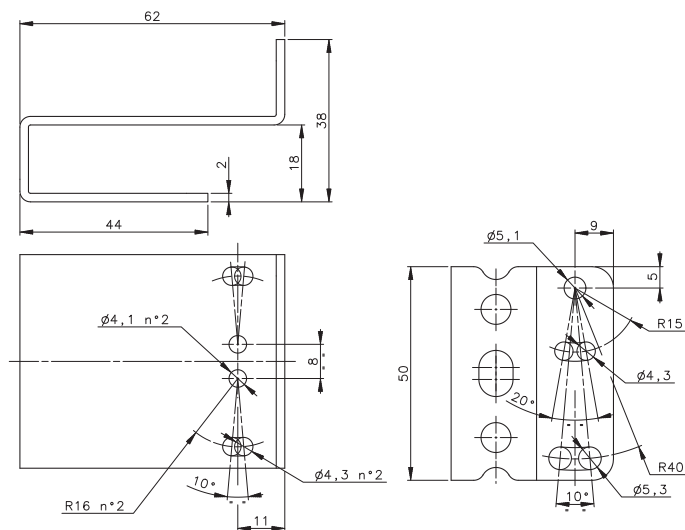

ST-5019

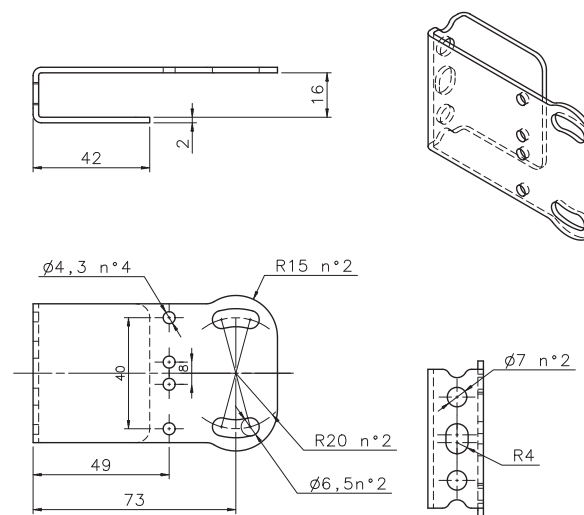

MODEL	DESCRIPTION	ORDER No.
ST-5018	protective bracket	95ACC5310
ST-5019	protective bracket	95ACC5320
ST-5020	mounting bracket	95ACC5330
ST-5021	mounting bracket	95ACC5340
ST-504	mounting bracket	95ACC2820
ST-5053	protective bracket	95ACC2410
ST-5054	protective bracket	95ACC2420
JOINT-S62	protective bracket with jointed support	95ACC2430

CABLES

TYPE	DESCRIPTION	LENGTH	MODEL	ORDER No.
Axial M12 Connector	4-pole, grey, P.V.C.	3 m	CS-A1-02-G-03	95A251380
		5 m	CS-A1-02-G-05	95A251270
		7 m	CS-A1-02-G-07	95A251280
		10 m	CS-A1-02-G-10	95A251390
Radial M12 Connector	4-pole, grey, P.V.C.	2 m	CS-A1-02-R-02	95A251540
		5 m	CS-A1-02-R-05	95A251560
		3 m	CS-A2-02-G-03	95A251360
		5 m	CS-A2-02-G-05	95A251240
Radial M12 Connector	4-pole, grey, P.V.C.	7 m	CS-A2-02-G-07	95A251245
		10 m	CS-A2-02-G-10	95A251260
		2 m	CS-A2-02-R-02	95A251550
		5 m	CS-A2-02-R-05	95A251570
Radial M12 Connector with LED (for PNP N.O. sensors)	4-pole, grey, P.V.C.	3 m	CS-A2-12-G-03	95A251400
		5 m	CS-A2-12-G-05	95A251350
		10 m	CS-A2-12-G-10	95A251370
Axial M12 Connector	4-pole, shielded, black, P.V.C.	3 m	CV-A1-22-B-03	95ACC1480
		5 m	CV-A1-22-B-05	95ACC1490
		10 m	CV-A1-22-B-10	95ACC1500
		15 m	CV-A1-22-B-15	95ACC2070
		25 m	CV-A1-22-B-25	95ACC2090
Radial M12 Connector	4-pole, shielded, black, P.V.C.	3 m	CV-A2-22-B-03	95ACC1540
		5 m	CV-A2-22-B-05	95ACC1550
		10 m	CV-A2-22-B-10	95ACC1560
		3 m	CS-A1-02-U-03	95ASE1120
Axial M12 Connector	4-pole, U.L., black, P.V.C.	5 m	CS-A1-02-U-05	95ASE1130
		10 m	CS-A1-02-U-10	95ASE1140
		15 m	CS-A1-02-U-15	95ASE1150
		25 m	CS-A1-02-U-25	95ASE1160
		Connector- not cabled	CS-A1-02-B-NC	G5085002
Radial M12 Connector	4-pole, black	Connector- not cabled	CS-A2-02-B-NC	G5085003

COMPACT SENSORS

S60

Extended range of standard "One for All" photoelectric compact sensors

- Complete range of optic functions, basic, advanced and laser class 1
- Models with coaxial optics for polarized retroreflective, contrast and luminescence sensors
- Trimmer or EASY touch™ setting with
- Remote, Keylock and Delay functions
- Standard cable or M12 connection with standard NPN or PNP configuration



APPLICATIONS

- Automatic machines
- Packaging lines
- Transportation lines
- Automatic warehouses
- Pharma and bottling

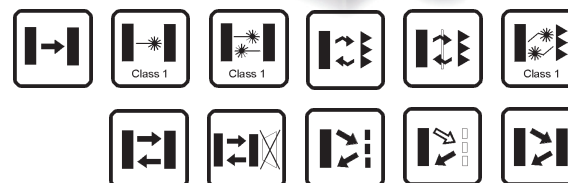

S60		
Through beam		0...20 m 0...60 m (class 1 LASER)
Polarized retroreflective (on R5 reflector)		0.1...8 m 0.1...20 m (class 1 LASER)
Polarized retroreflective coaxial (on R5 reflector)		0...4 m
Polarized retroreflective coaxial transparent (on R5 reflector)		0...2 m
Diffuse proximity		0...100 cm 0...200 cm (long range) 0...60 cm (class 1 LASER)
Background suppression		7...20 cm
Contrast Sensor		5...10 cm (class 1 LASER)
Luminescence Sensor		19 mm ±2 mm (white emission)
Power supply	Vdc	10...30 V 18...30 V
	Vac	
	Vac/dc	
Output	PNP	▪
	NPN	▪
	NPN/PNP	
	relay	
	other	
Connection	cable	▪
	connector	▪
	pig-tail	
Approximate dimensions (mm)		50x50x15 mm
Housing material		ABS
Mechanical protection		IP67

TECHNICAL DATA

Power supply	10 ... 30 Vdc
Ripple	≤ 2 Vpp max.
Consumption (output current excluded)	≤ 40 mA max.
Light emission	red LED 660 nm (mod. S60...B01/B51/T51/C01) IR LED 880 nm (mod. S60...C11/G00) white LED 400-700 nm (mod. S60...W08) UV LED 370 nm (mod. S60...U08) red Laser 650 nm (mod. S60...G00/B01/C01/M08)
Setting	sensitivity trimmer (mod. B01/B51/C01/C11/F01/T51)
Operating mode	LIGHT mode on N.O. output / DARK mode on N.C. output (mod.S60...C01/C11/M08/U08) DARK mode on N.O. output / LIGHT mode on N.C. output (mod.S60...B01/B51/F01/T51) LIGHT mode on N.O. output / remote input (mod.M08/W08/U08)
Indicators	yellow OUTPUT LED (S60 all models excluded G00) green STABILITY LED (mod. S60...F01/B01/B51/T51/C01/C11) POWER LED (mod. S60 LASER...F01/B01/C01) green/red READY/ERROR LED (mod. S60...M08/W08/U08)
Output	PNP or NPN; NO; NC (mod. S60)
Output current	100 mA max.
Saturation voltage	2 V max.
Response time	0,5 ms (mod. S60...A00/B01/T01/C10/C21/C01/D00/E01/U08) 2 ms (mod. S60...F01/G00) 1 ms (mod. S50...M08, A00/B01/C01/C10/G00) 4 ms (mod. S60) 100 μs (mod. S60...W08) 333 μs (Laser mod. S60)
Switching frequency	1 kHz (mod. S60...A00/B01/T01/C10/C21/C01/D00/E01/U08) 250 Hz (mod. S50...F01/G00) 500 Hz (mod. S60...M08, A00/B01/C01/C10/G00) 5 kHz (mod. S60...W08) 1,5 kHz (Laser mod. S60)
Connection	2 m Ø 4 mm cable / M12 4-pole connector
Dielectric strength	500 VAC, 1 min between electronic parts and housing
Insulating resistance	>20 MΩ, 500 VDC between electronic parts and housing
Electrical protection	Class 2
Mechanical protection	IP67
Ambient light rejection	according to EN 60947-5-2
Vibrations	0.5 mm amplitude, 10 ... 55 Hz frequency, for every axis (EN60068-2-6)
Shock resistance	11 ms (30 G) 6 shock for every axis (EN60068-2-27)
Housing material	ABS
Lens material	window in PMMA, lenses in glass and polycarbonate
Operating temperature	-10 ... 50 °C (Laser Models) -25 ... 55 °C (LED Models)
Storage temperature	-25 ... 70 °C
Weight	90 g. max. cable vers. / 40 g. max. connector vers.

COMPACT SENSORS

DIMENSIONS

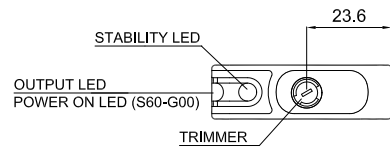
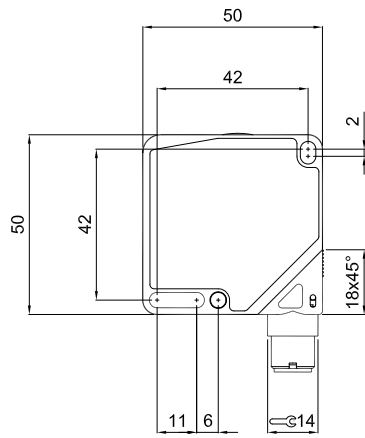

mm

S60...B01/C01/C11/F01/G00
S60-PL...B01/C01/F01/G00

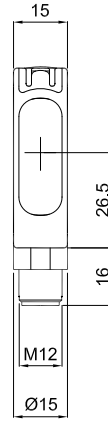

CABLE VERSION

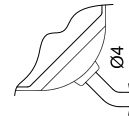

S60...B51/T51

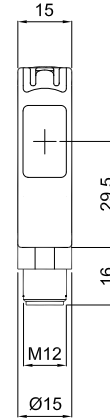

S60...W08/U08

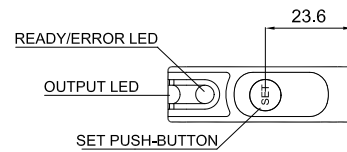
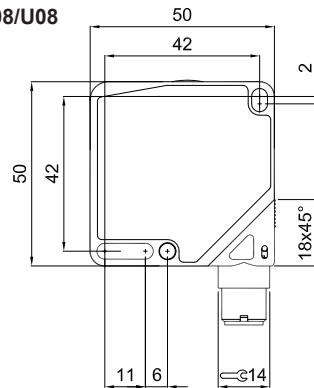

mm

CABLE VERSION

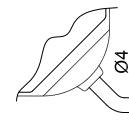

S60...M08
S60-PL...M08

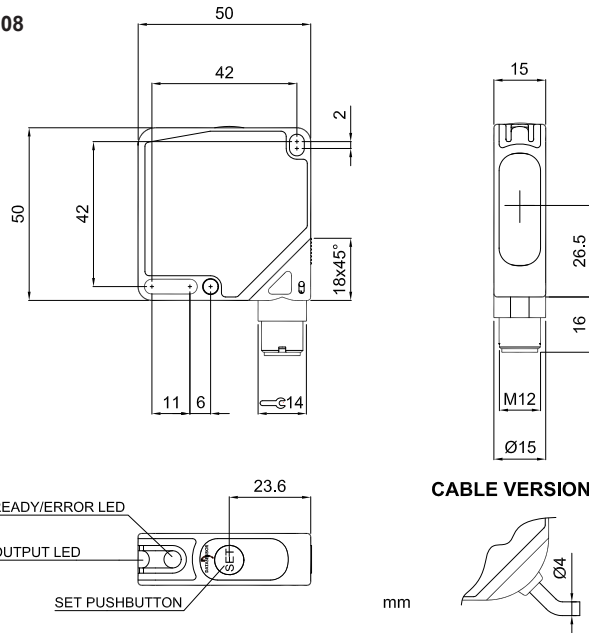

CONNECTIONS



S60-PA-2

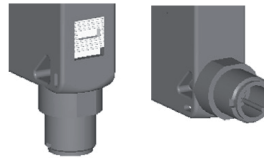
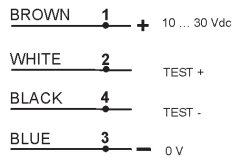

S60-PA-5

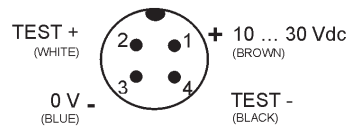

S60...G00
S60-PL...G00

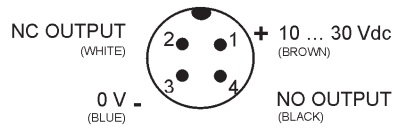
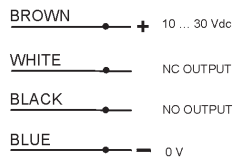

S60...B01,B51,C01,C11,T51,F01
S60-PL...B01,C01,F01

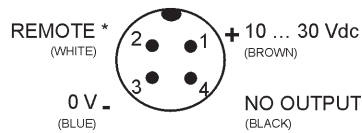
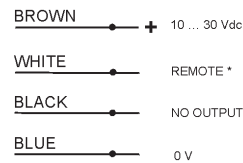

S60...W08,U08,M08
S60-PL...M08

COMPACT SENSORS

INDICATORS AND SETTINGS

INFRARED EMISSION G00 - LASER RED EMISSION G00/F01



RECEIVER



A Output status and stability LEDs (receiver); power on LED (emitter)

B Adjustment trimmer (receiver)

EMITTER



C M12 connector output

D Cable output

Single-turn trimmer for sensitivity adjustment. Rotate clockwise direction to increase the operating distance. Decrease sensitivity to increase resolution. Only for Receiver model

B01/B51/T51/C01/C11



A Output status yellow LED and green Stability LED

B Adjustment trimmer

C M12 connector output

D Cable output

Single-turn trimmer for sensitivity adjustment. Rotate clockwise to increase the operating distance.

RED LASER MODEL B01/C01



A Output status yellow LED and green Power LED

B Teach-in push-button

C M12 connector output

D Cable output

Single-turn trimmer for sensitivity adjustment. Rotate clockwise to increase the operating distance.

W08/U08/M08/M08 LASER



A Output status and READY/ERROR LEDs

B Teach-in push-button

C M12 connector output orientable in two positions

D Cable output

Teach-in button for setting. EASYtouch™ provides two setting modes: standard or fine. Please refer to instructions manual for operating details.

DETECTION DIAGRAMS

S60...F01,G00

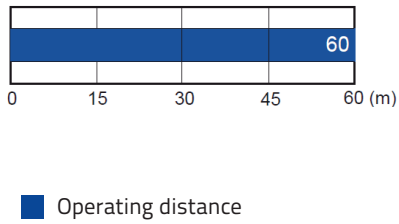
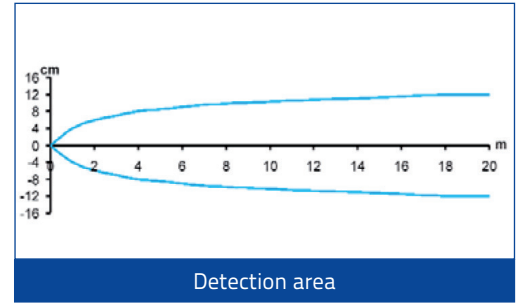
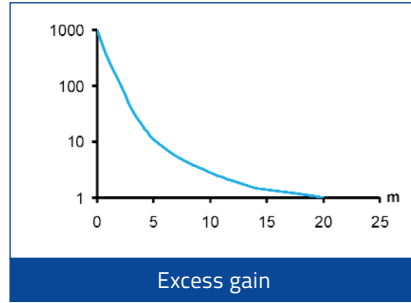
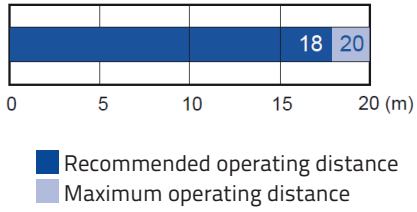

S60-PL...F01,G00

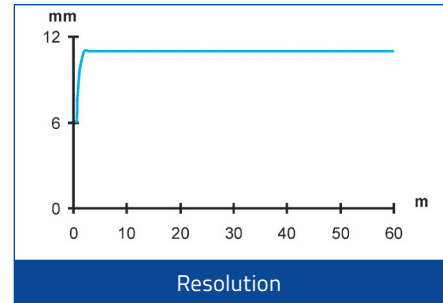
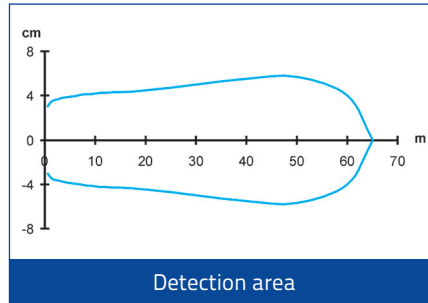

S60...B01

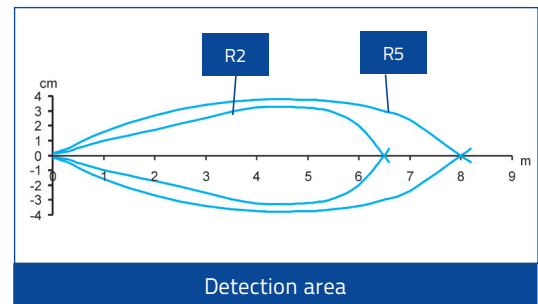
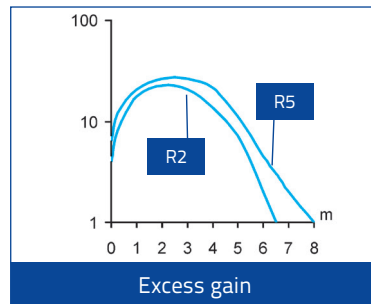
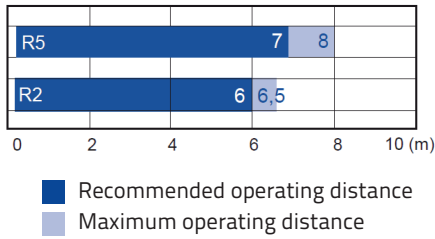

High efficiency reflectors can be used to obtain larger operating distances. Refer to **Reflectors (A.01)** of the **General Catalogue**.

S60-PL...B01

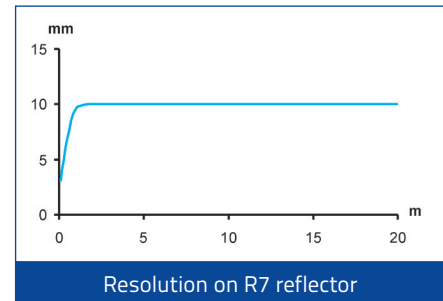
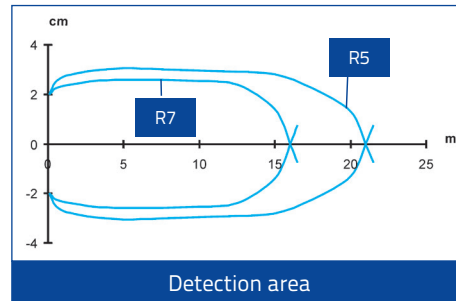
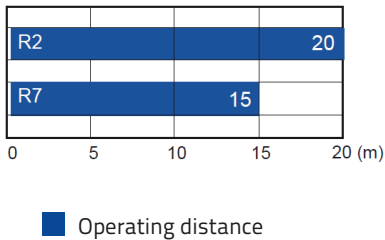

High efficiency reflectors can be used to obtain larger operating distances. Refer to **Reflectors (A.01)** of the **General Catalogue**.

COMPACT SENSORS

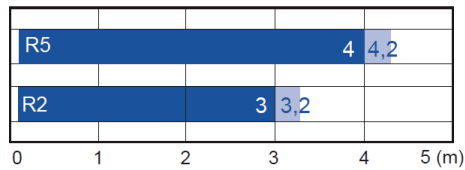

■ Recommended operating distance
■ Maximum operating distance

High efficiency reflectors can be used to obtain larger operating distances. Refer to **Reflectors**.

S60...B51

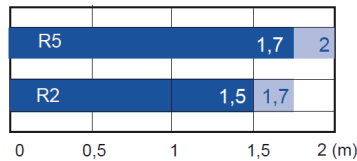
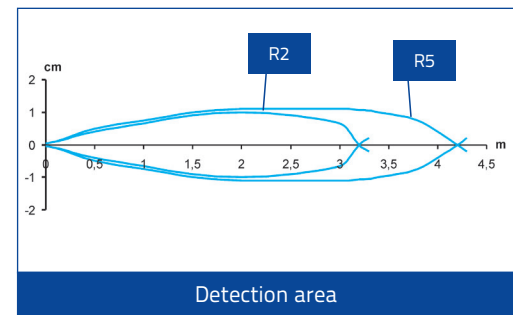
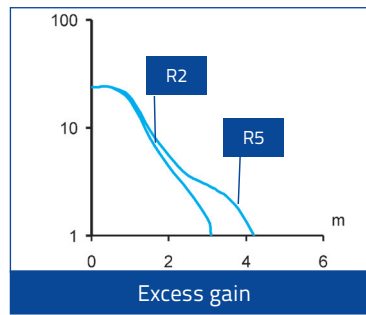

■ Recommended operating distance
■ Maximum operating distance

S60...T51

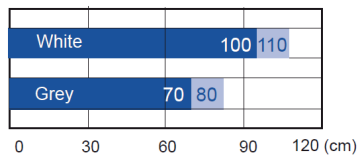
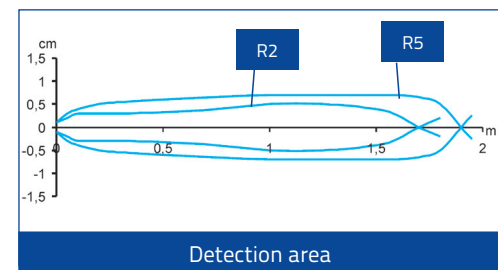
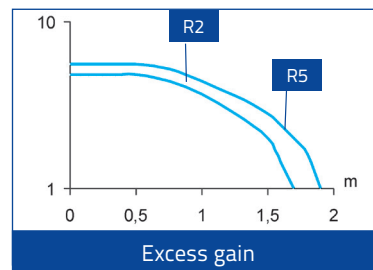

■ Recommended operating distance
■ Maximum operating distance

S60...C01

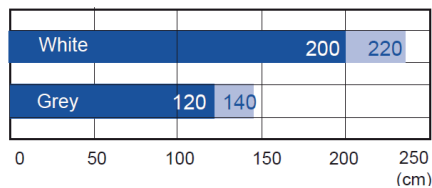
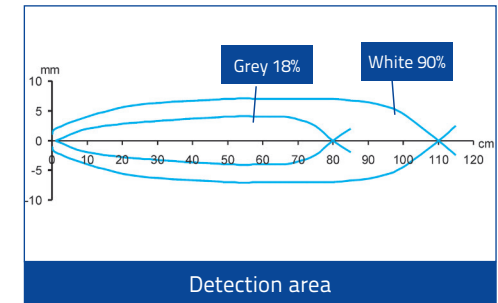
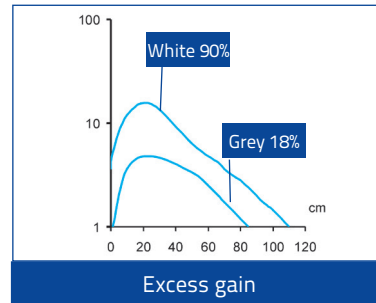

■ Recommended operating distance
■ Maximum operating distance

S60...C11

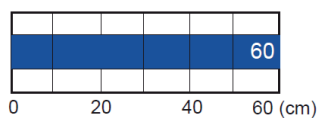
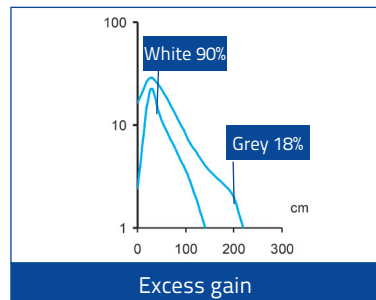

■ Operating distance

S60-PL...C01

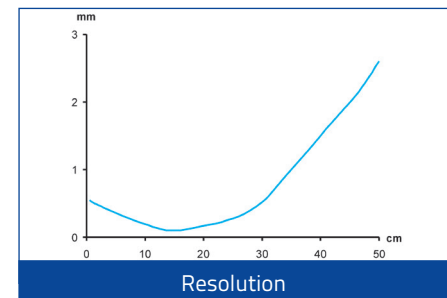
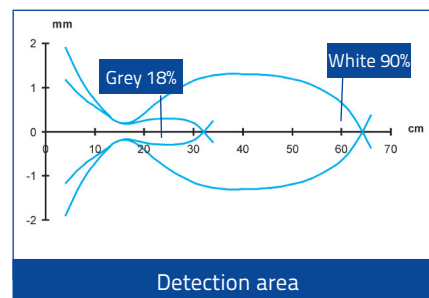

S60...M08

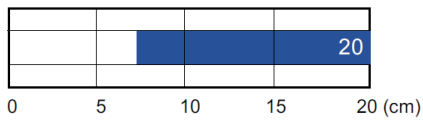

■ Operating distance

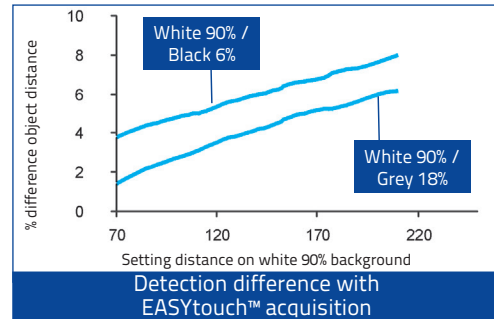

S60-PL...M08

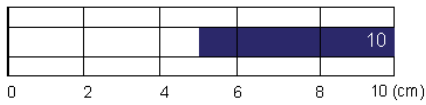

■ Operating distance

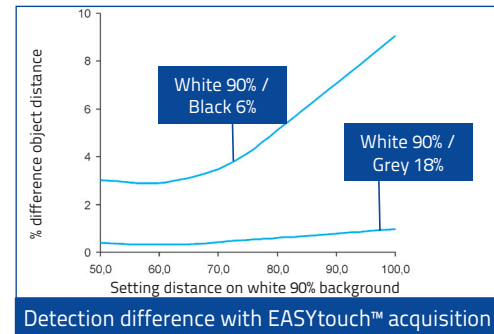

S60...W08

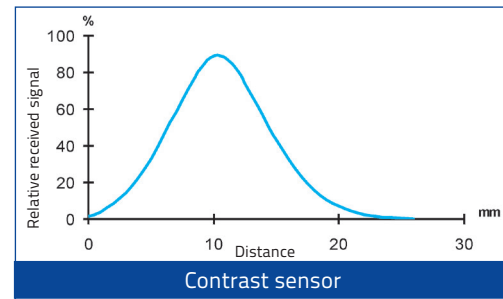
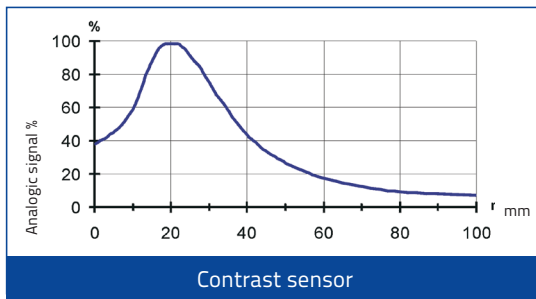

S60...U08

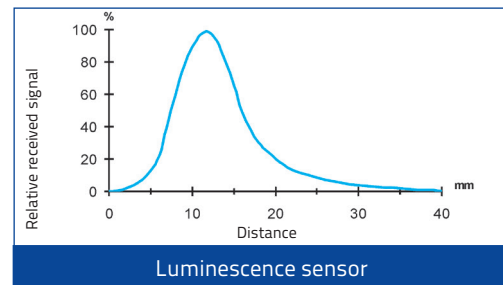
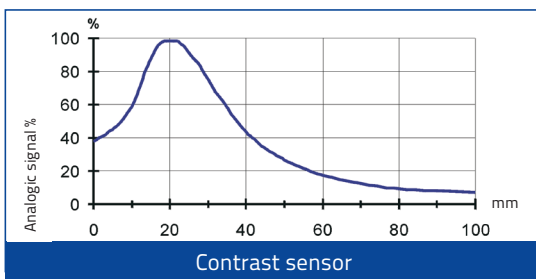

COMPACT SENSORS

MODEL SELECTION AND ORDER INFORMATION

MODEL	FUNCTION	N° ORDER	PAGE
S60-PA-2-B01-NN	polarized retroreflective	956201460	6
S60-PA-2-B01-PP	polarized retroreflective	956201300	6
S60-PA-2-C01-NN	diffuse proximity	956201470	14
S60-PA-2-C01-PP	diffuse proximity	956201310	14
S60-PA-2-C11-NN	long diffuse proximity	956201480	16
S60-PA-2-C11-PP	long diffuse proximity	956201320	16
S60-PA-2-F01-NN	receiver	956201490	2
S60-PA-2-F01-PP	receiver	956201330	2
S60-PA-2-G00-XG	emitter	956201340	2
S60-PA-2-T51-NN	retroreflective for transparents	956201530	12
S60-PA-2-T51-PP	retroreflective for transparents	956201380	12
S60-PA-2-U08-NH	luminescence sensor	956201540	28
S60-PA-2-U08-PH	luminescence sensor	956201390	28
S60-PA-2-W08-NH	contrast sensor	956201550	26
S60-PA-2-W08-PH	contrast sensor	956201400	26
S60-PA-5-B01-NN	polarized retroreflective	956201180	6
S60-PA-5-B01-PP	polarized retroreflective	956201040	6
S60-PA-5-B51-NN	coaxial polarized retroreflective	956201630	8
S60-PA-5-B51-PP	coaxial polarized retroreflective	956201620	8
S60-PA-5-C01-NN	diffuse proximity	956201190	14
S60-PA-5-C01-PP	diffuse proximity	956201050	14
S60-PA-5-C11-NN	long diffuse proximity	956201200	16
S60-PA-5-C11-PP	long diffuse proximity	956201110	16
S60-PA-5-F01-NN	receiver	956201210	2
S50-PA-5-F01-PP	receiver	956201060	2
S60-PA-5-G00-XG	emitter	956201070	2
S60-PA-5-M08-NH	background suppression	956201220	20
S60-PA-5-M08-PH	background suppression	956201080	20

MODEL	FUNCTION	N° ORDER	PAGE
S60-PA-5-T51-NN	retroreflective for transparents	956201250	12
S60-PA-5-T51-PP	retroreflective for transparents	956201100	12
S60-PA-5-U08-NH	luminescence sensor	956201010	28
S60-PA-5-U08-PH	luminescence sensor	956201000	28
S60-PA-5-W08-NH	contrast sensor	956201030	26
S60-PA-5-W08-PH	contrast sensor	956201020	26
S60-PL-2-B01-NN	laser polarized retroreflective	956201560	10
S60-PL-2-B01-PP	laser polarized retroreflective	956201410	10
S60-PL-2-C01-NN	laser diffuse proximity	956201640	18
S60-PL-2-C01-PP	laser diffuse proximity	956201650	18
S60-PL-2-F01-NN	laser receiver	956201570	4
S60-PL-2-F01-PP	laser receiver	956201420	4
S60-PL-2-G00-XG	laser emitter	956201430	4
S60-PL-2-M08-NH	laser background suppression	956201580	22
S60-PL-2-M08-PH	laser background suppression	956201440	22
S60-PL-5-B01-NN	laser polarized retroreflective	956201260	10
S60-PL-5-B01-PP	laser polarized retroreflective	956201120	10
S60-PL-5-C01-NN	laser diffuse proximity	956201660	18
S60-PL-5-C01-PP	laser diffuse proximity	956201670	18
S60-PL-5-F01-NN	laser receiver	956201270	4
S50-PL-5-F01-PP	laser receiver	956201140	4
S60-PL-5-G00-XG	laser emitter	956201150	4
S60-PL-5-M08-NH	laser background suppression	956201280	22
S60-PL-5-M08-PH	laser background suppression	956201160	22

ACCESSORIES

The series is compatible with the following Datalogic Automation accessories

- CS connectors
- R reflectors

New accessories dedicated to the S60 series have been developed to cover all the fixing requirements and improve functioning.

ACCESSORY SELECTION AND ORDER INFORMATION

MODEL	DESCRIPTION	ORDER N°
ST-5018	protection bracket	95ACC5310
ST-5019	protection bracket	95ACC5320
ST-5020	fixing bracket	95ACC5330
ST-5021	fixing bracket	95ACC5340
JOINT-60	protection bracket with jointed support	95ACC5350
ST-504	S6/S60 fixing bracket	95ACC2820

ACCESSORIES DIMENSIONS

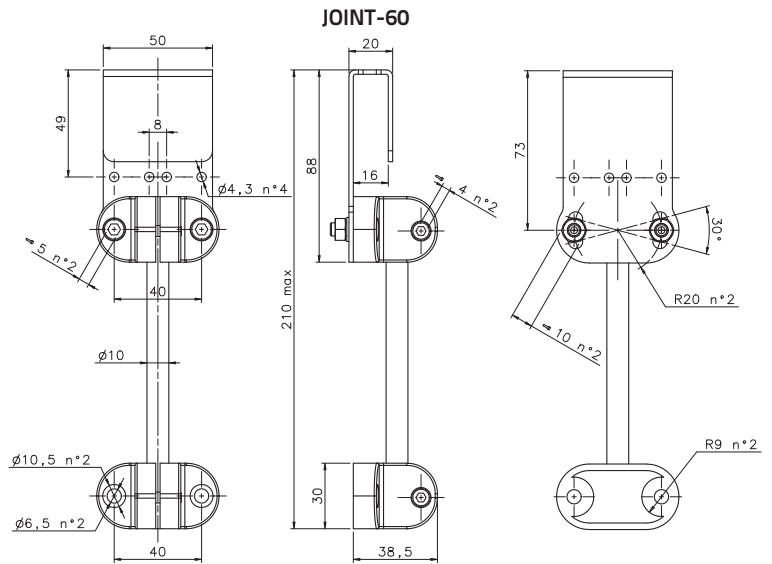
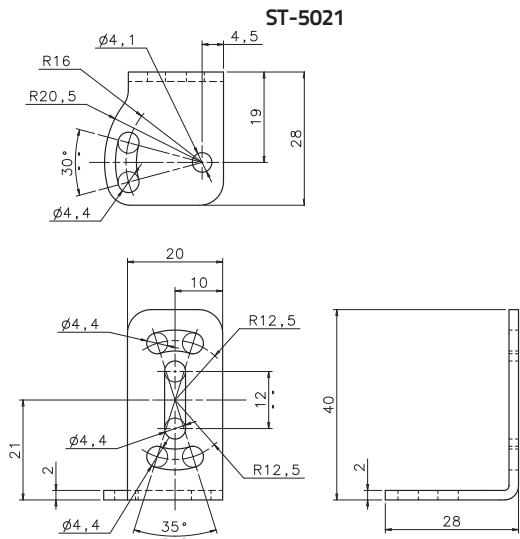
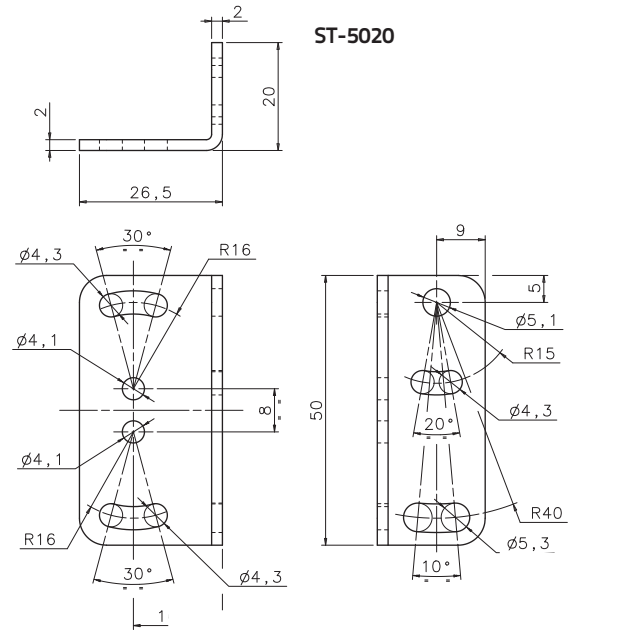
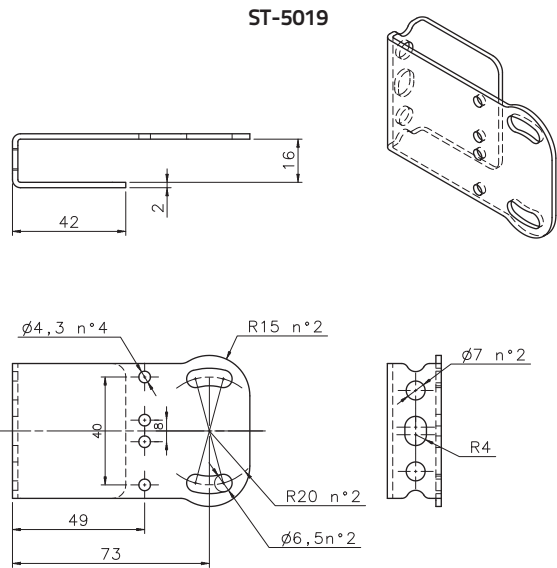
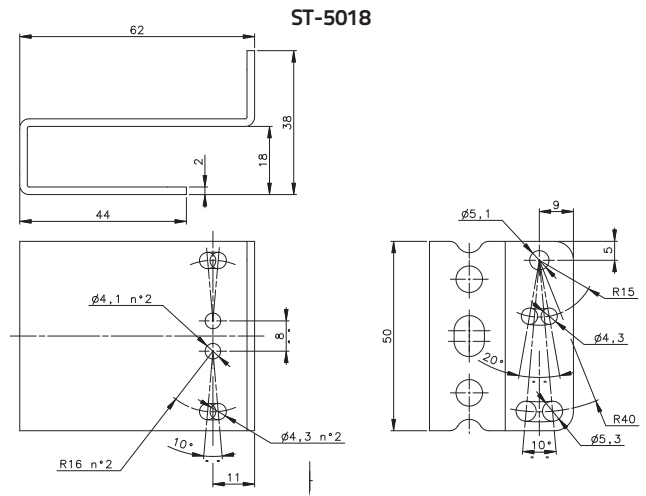
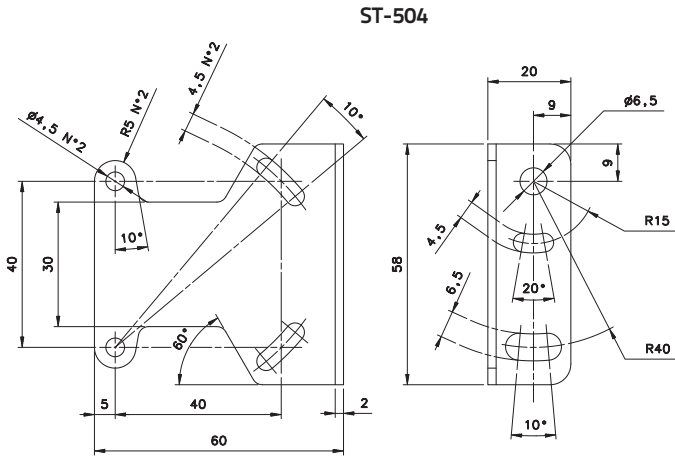

COMPACT SENSORS

S62

The most complete universal sensor in a compact 50x50 mm housing

- Sensors with red, infrared LED or LASER emission
- Background suppression from 3 cm to 2 m
- Polarized retroreflective up to 20 m
- Multivoltage 24-240Vac/24-60Vdc with Relay output
- NPN/PNP output NO-NC configuration



APPLICATIONS

- Processing and Packaging machinery
- Conveyor lines, material handling



S62		
Through beam		0...25 m
Retroreflective (on R2 reflector)		0,1...13 m
Polarized retroreflective		0,1...8 m 0,3...20 m (class 2 LASER)
Diffuse proximity		short 0...900 mm, long 0...2000 mm 0...900 mm (class 2 LASER)
Background suppression		short 30...300 mm medium 60...600 mm long 60...1200 mm very long 200...2000 mm short LASER 30...150 mm (class 2 LASER) long LASER 50...350 mm (class 2 LASER)
Power supply	Vdc	10...30 V
	Vac	
	Vac/dc	24/240 Vac/24...60 Vdc
	PNP	▪
Output	NPN	▪
	NPN/PNP	▪
	relay	▪
	other	
Connection	cable	▪
	connector	▪
	pig-tail	
Approximate dimensions (mm)		18x50x50
Housing material		ABS
Mechanical protection		IP67

TECHNICAL DATA

Power supply	10 ... 30 Vdc (mod. S62...2/5) 24...240 Vac / 24...60 Vdc (mod. S62...1)
Ripple	2 Vpp max. (mod. S62...2/5), 10% max. (mod. S62...1) 30 mA max. (mod. S62...2/5)
Consumption (output current excluded)	3 VA max. (mod. S62...1)
Light emission	red LED 640 nm (mod. S62-PA...A/B/C/G/M01/M05/M11/M15) IR LED 880 nm (mod. S62-PA...M21/M25/M31/M35) red Laser 645...665 nm (mod. S62-PL)
Setting	sensitivity adjustment trimmer
Operating mode	mono-turn LIGHT/DARK trimmer (mod. S62...RX/PN)
Indicators	yellow OUTPUT LED green STABILITY LED, POWER LED (S62...G)
Output	PNP or NPN N.O./N.C. (mod. S62...PP/NN); NPN/PNP (mod. S62...PN); electromechanical SPDT 250 Vac/30 Vdc (mod. S62...RX)
Output current	100 mA max. (mod. S62...2/5), 2 A max. (mod. S62...1)
Saturation voltage	2 V max. (mod. S62...2/5)
Response time	25 ms (mod. S62...1) 1,5 ms (mod. S62...M3x) 1 ms (mod. S62...2/5-F/G/M2x) 500 µs (mod. S62-PA...2/5-A/B/C/M0x/M1x) 200 µs (mod. S62-PL...B/C/M11) 140 µs (mod. S62-PL...M01)
Switching frequency	20 Hz (mod. S62...1) 330 Hz (mod. S62...M3x) 500 Hz (mod. S62...2/5-F/G/M2x) 1 kHz (mod. S62-PA...2/5-A/B/C/M0x/M1x) 2,5 kHz (mod. S62-PL...B/C/M11) 3,5 kHz (mod. S62-PL...M01)
Connection	M12 4-pole connector, 2 m Ø 4 mm cable vers., 2 m Ø 5 mm cable vers.
Dielectric strength	500 Vac 1 min., between electronics and housing
Insulation resistance	>20 MΩ 500 Vdc, between electronics and housing
Mechanical protection	IP67
Ambient light rejection	According to EN 60947-5-2
Vibrations	0.5 mm amplitude, 10 ... 55 Hz frequency, for each axis (EN60068-2-6)
Shock resistance	11ms (30G) 6 shock for every axis (EN60068-2-27)
Housing material	ABS
Lens material	PMMA window, polycarbonate lens
Operating temperature	-10 ... 55 °C
Storage temperature	-20 ... 70 °C
Weight	40 g max. conn. vers., 90 max. cable vers.

DIMENSIONS

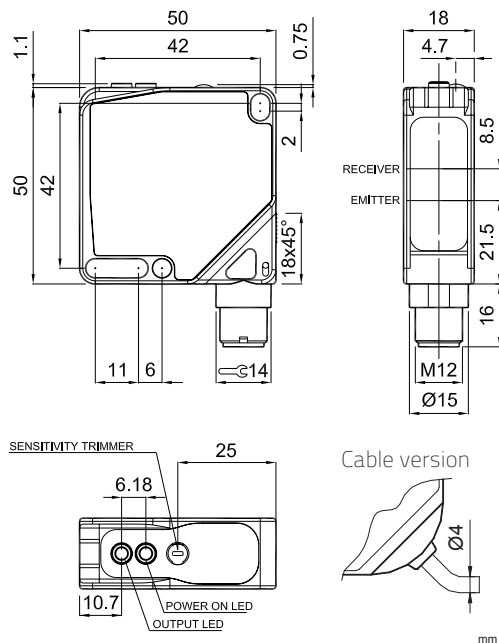

Background suppression

Laser version

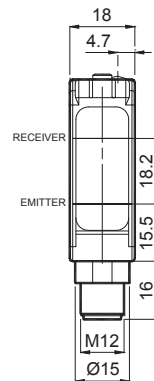
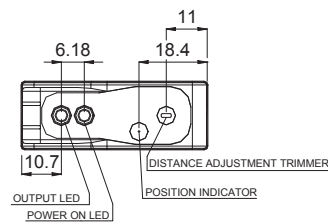

Led version

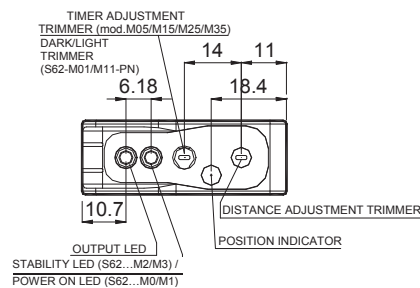

COMPACT SENSORS

CONNECTIONS

VDC MODELS

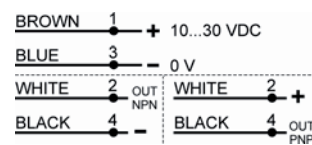
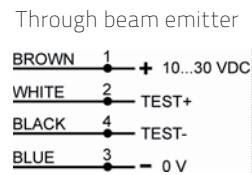
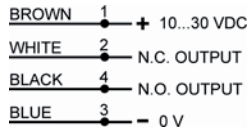

M12 CONNECTOR

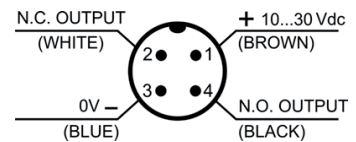

VAC MODELS

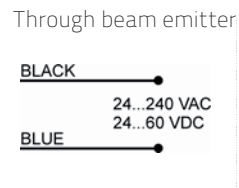
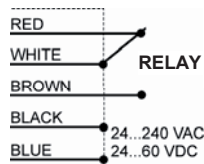

INDICATORS AND SETTINGS

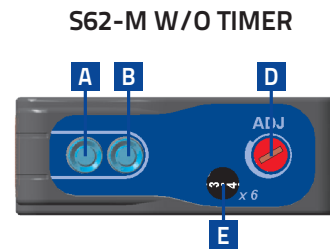
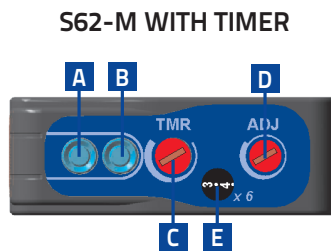
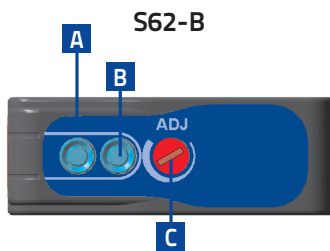

- A** Output status LED
- B** Stability LED or Power ON LED (laser vers.)
- C** Timer adjustment trimmer

- D** Distance adjustment trimmer
- E** Geared numeric scale
- F** M12 connector output
- G** Cable output

DETECTION DIAGRAMS OF MODELS WITH LED EMISSION

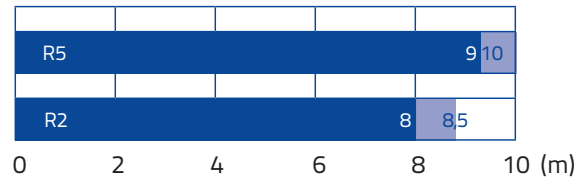
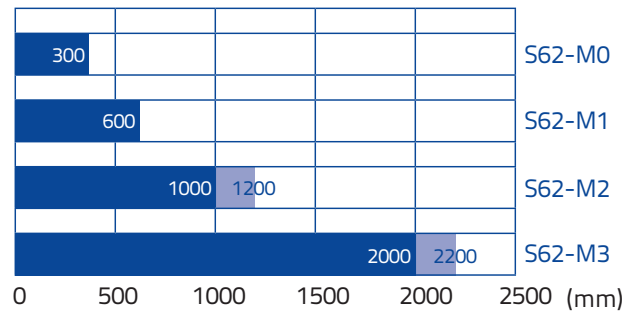
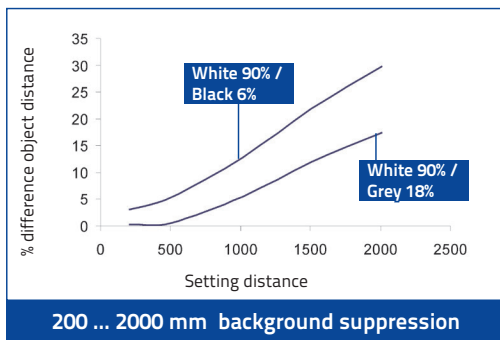
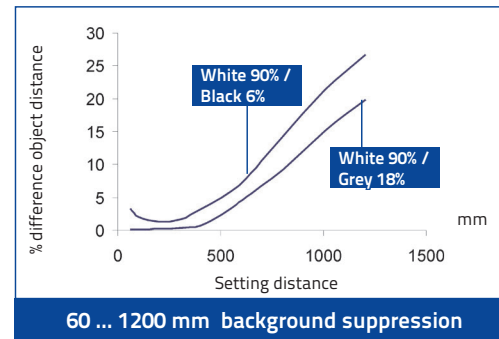
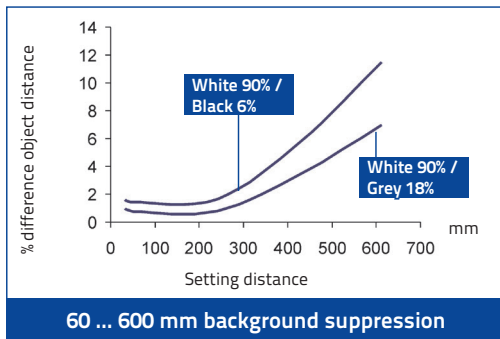
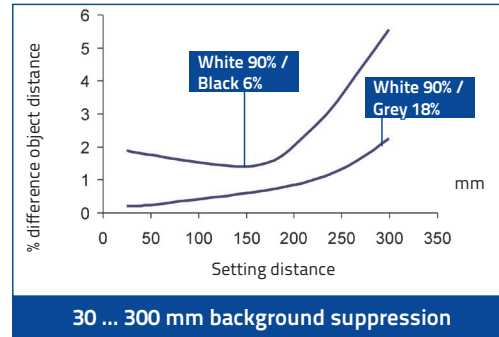
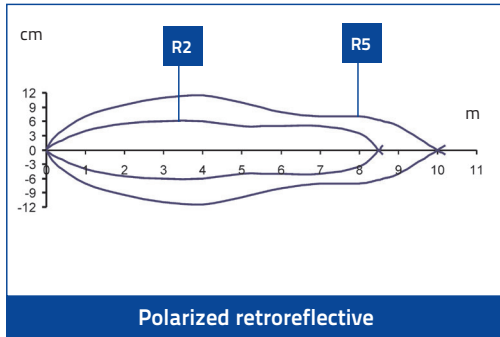

Recommended operating distance
 Maximum operating distance

COMPACT SENSORS

DETECTION DIAGRAMS OF MODELS WITH LASER EMISSION

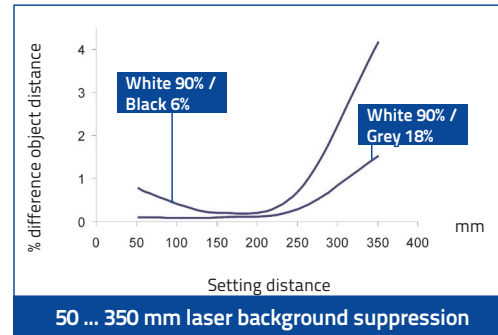
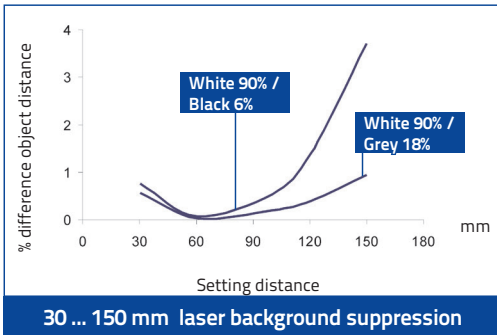
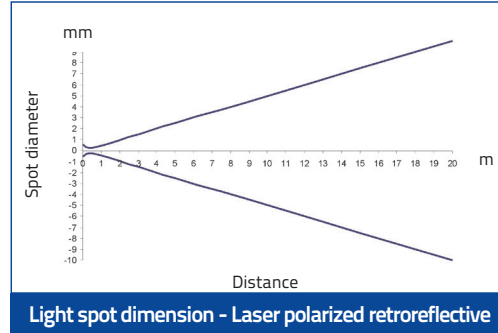
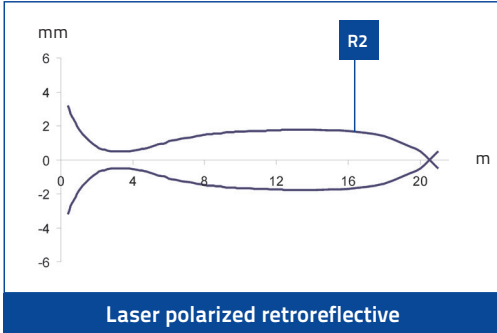

Reflector operating distances (m)				
R1	R2	R6	R7 / R20	R8
0.3 ... 16	0.3 ... 20	0.4 ... 22	0.3 ... 22	0.2 ... 2

The use of the RT3970 reflecting tape is suggested.

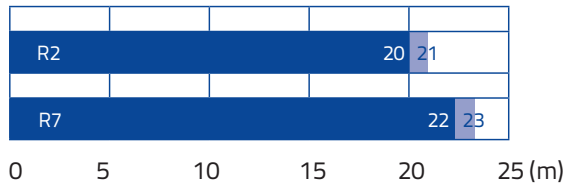
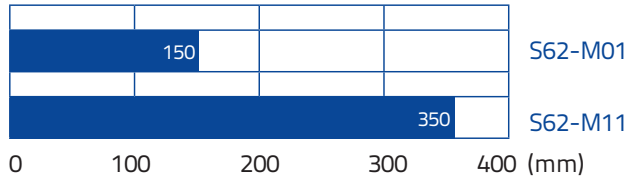

- Recommended operating distance
- Maximum operating distance

MODEL SELECTION AND ORDER INFORMATION

OPTIC FUNCTION	EMISSION	CONNECTION	OUTPUT	MODEL	ORDER No.	
Retroreflective	LED (red 640nm)	2m Cable	PNP/NPN	S62-PA-2-A01-PN	956211240	
		M12 Connector	PNP/NPN	S62-PA-5-A01-PN	956211310	
		Vac relay	Relay	S62-PA-1-A01-RX	956211180	
Polarized retroreflective	LED (red 640nm)	2m Cable	PNP/NPN	S62-PA-2-B01-PN	956211250	
		M12 Connector	PNP	S62-PA-2-B01-PP	956211010	
			NPN	S62-PA-5-B01-NN	956211020	
			PNP/NPN	S62-PA-5-B01-PN	956211320	
	Vac relay	Relay	S62-PA-5-B01-PP	956211000		
	LASER	M12 Connector	Relay	S62-PA-1-B01-RX	956211190	
			NPN	S62-PL-5-B01-NN	956211100	
Short diffused proximity	LED (red 640nm)	2m Cable	PNP	S62-PL-5-B01-PP	956211110	
			NPN	S62-PA-2-C01-NN	956211420	
			PNP/NPN	S62-PA-2-C01-PN	956211260	
		M12 Connector	PNP	S62-PA-2-C01-PP	956211380	
			NPN	S62-PA-5-C01-NN	956211500	
			PNP/NPN	S62-PA-5-C01-PN	956211330	
	Vac relay	Relay	S62-PA-5-C01-PP	956211460		
	LASER	2m Cable	Relay	S62-PA-1-C01-RX	956211200	
			NPN	S62-PL-2-C01-NN	956211440	
			PNP	S62-PL-2-C01-PP	956211400	
		M12 Connector	NPN	S62-PL-5-C01-NN	956211520	
			PNP	S62-PL-5-C01-PP	956211480	
PNP/NPN			S62-PA-5-C01-PN	956211480		
Long diffused proximity	LED (red 640nm)	2m Cable	NPN	S62-PA-2-C11-NN	956211430	
			PNP/NPN	S62-PA-2-C11-PN	956211270	
			PNP	S62-PA-2-C11-PP	956211390	
		M12 Connector	NPN	S62-PA-5-C11-NN	956211510	
			PNP/NPN	S62-PA-5-C11-PN	956211340	
			PNP	S62-PA-5-C11-PP	956211470	
	Vac relay	Relay	S62-PA-1-C11-RX	956211210		
	Through beam receiver	-	2m Cable	NPN	S62-PA-2-F01-NN	956211450
				PNP/NPN	S62-PA-2-F01-PN	956211290
PNP				S62-PA-2-F01-PP	956211410	
M12 Connector			NPN	S62-PA-5-F01-NN	956211530	
			PNP/NPN	S62-PA-5-F01-PN	956211360	
			PNP	S62-PA-5-F01-PP	956211490	
Vac relay			Relay	S62-PA-1-F01-RX	956211220	
Through beam emitter			LED (red 640nm)	2m Cable	-	S62-PA-2-G00-XG
	M12 Connector	-		S62-PA-5-G00-XG	956211370	
	Vac relay	-		S62-PA-1-G00-XX	956211230	
Background suppression (short distance)	LED (red 640nm)	2m Cable	PNP/NPN	S62-PA-2-M01-PN	956211280	
			PNP	S62-PA-2-M01-PP	956201841	
			NPN	S62-PA-5-M01-NN	956201811	
		M12 Connector	PNP/NPN	S62-PA-5-M01-PN	956211350	
			PNP	S62-PA-5-M01-PP	956201831	
			NPN	S62-PA-5-M05-NN	956201801	
	LASER	M12 Connector	PNP	S62-PA-5-M05-PP	956201821	
			NPN	S62-PL-5-M01-NN	956211120	
			PNP	S62-PL-5-M01-PP	956211130	
			PNP	S62-PL-5-M01-PP	956211130	
Background suppression (medium distance)	LED (red 640nm)	2m Cable	PNP	S62-PA-2-M11-PP	956201891	
			NPN	S62-PA-5-M11-NN	956201861	
			PNP	S62-PA-5-M11-PP	956201881	
	LASER	M12 Connector	NPN	S62-PA-5-M15-NN	956201851	
			PNP	S62-PA-5-M15-PP	956201871	
			NPN	S62-PL-5-M11-NN	956211140	
PNP	S62-PL-5-M11-PP	956211150				
Background suppression (long distance)	LED (infrared 880nm)	2m Cable	PNP	S62-PA-2-M21-PP	956201940	
			NPN	S62-PA-5-M21-NN	956201910	
			PNP	S62-PA-5-M21-PP	956201900	
		M12 Connector	NPN	S62-PA-5-M25-NN	956201930	
			PNP	S62-PA-5-M25-PP	956201920	
			PNP	S62-PA-2-M31-PP	956211050	
Background suppression (very long distance)	LED (infrared 880nm)	M12 Connector	NPN	S62-PA-5-M31-NN	956211060	
			PNP	S62-PA-5-M31-PP	956211070	
			NPN	S62-PA-5-M35-NN	956211080	
			PNP	S62-PA-5-M35-PP	956211090	

COMPACT SENSORS

ACCESSORIES

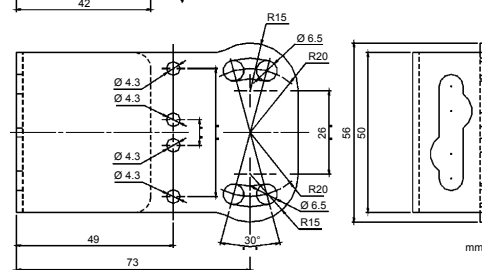
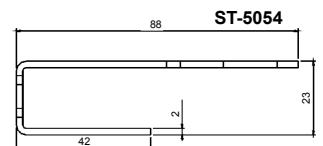
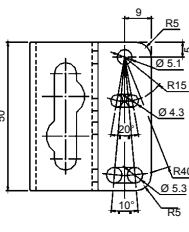
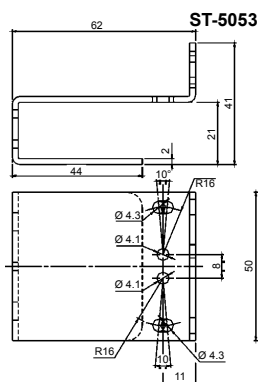
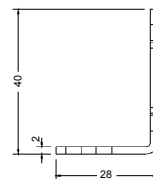
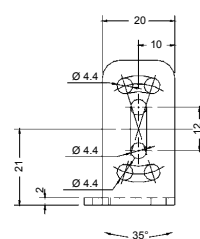
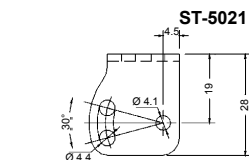
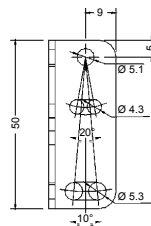
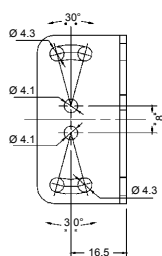
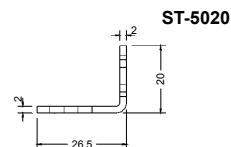
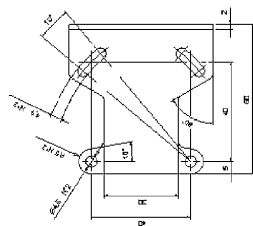
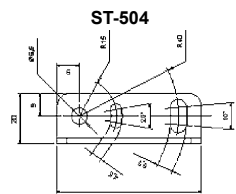

ST-5018

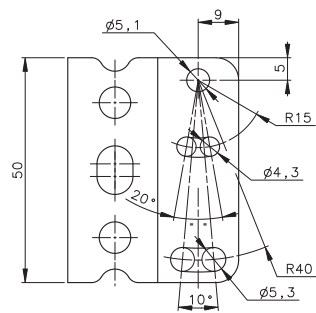
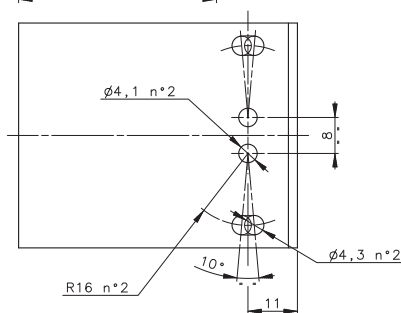
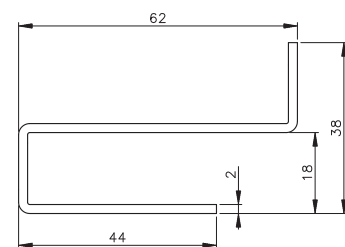

ST-5019

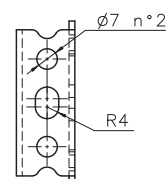
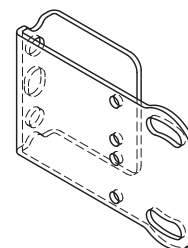
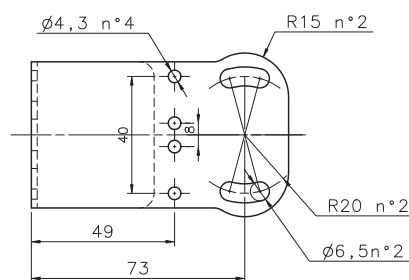
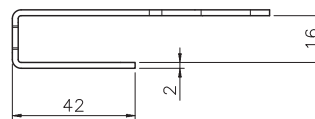



MODEL	DESCRIPTION	ORDER No.
ST-5018	protective bracket	95ACC5310
ST-5019	protective bracket	95ACC5320
ST-5020	mounting bracket	95ACC5330
ST-5021	mounting bracket	95ACC5340
ST-504	mounting bracket	95ACC2820
ST-5053	protective bracket	95ACC2410
ST-5054	protective bracket	95ACC2420
JOINT-S62	protective bracket with jointed support	95ACC2430

CABLES

TYPE	DESCRIPTION	LENGTH	MODEL	ORDER No.
Axial M12 Connector	4-pole, grey, P.V.C.	3 m	CS-A1-02-G-03	95A251380
		5 m	CS-A1-02-G-05	95A251270
		7 m	CS-A1-02-G-07	95A251280
		10 m	CS-A1-02-G-10	95A251390
	4-pole, P.U.R.	2 m	CS-A1-02-R-02	95A251540
		5 m	CS-A1-02-R-05	95A251560
Radial M12 Connector	4-pole, grey, P.V.C.	3 m	CS-A2-02-G-03	95A251360
		5 m	CS-A2-02-G-05	95A251240
		7 m	CS-A2-02-G-07	95A251245
		10 m	CS-A2-02-G-10	95A251260
	4-pole, P.U.R.	2 m	CS-A2-02-R-02	95A251550
		5 m	CS-A2-02-R-05	95A251570
Radial M12 Connector with LED (for PNP N.O. sensors)	4-pole, grey, P.V.C.	3 m	CS-A2-12-G-03	95A251400
		5 m	CS-A2-12-G-05	95A251350
		10 m	CS-A2-12-G-10	95A251370
Axial M12 Connector	4-pole, shielded, black, P.V.C.	3 m	CV-A1-22-B-03	95ACC1480
		5 m	CV-A1-22-B-05	95ACC1490
		10 m	CV-A1-22-B-10	95ACC1500
		15 m	CV-A1-22-B-15	95ACC2070
		25 m	CV-A1-22-B-25	95ACC2090
Radial M12 Connector	4-pole, shielded, black, P.V.C.	3 m	CV-A2-22-B-03	95ACC1540
		5 m	CV-A2-22-B-05	95ACC1550
		10 m	CV-A2-22-B-10	95ACC1560
Axial M12 Connector	4-pole, U.L., black, P.V.C.	3 m	CS-A1-02-U-03	95ASE1120
		5 m	CS-A1-02-U-05	95ASE1130
		10 m	CS-A1-02-U-10	95ASE1140
		15 m	CS-A1-02-U-15	95ASE1150
		25 m	CS-A1-02-U-25	95ASE1160
	Radial M12 Connector	4-pole, black	Connector- not cabled	CS-A1-02-B-NC
Connector- not cabled			CS-A2-02-B-NC	G5085003

COMPACT SENSORS

S90

Extended range of compact photoelectric sensors in a metal housing

- Background suppression and polarized retroreflective
- Class 1 LASER models for long distance detection
- Contrast and UV Luminescence sensors
- Industrial IP67 metal housing
- Standard 4-wire NO-NC NPN or PNP output



APPLICATIONS

- Processing and Packaging machinery
- Conveyor lines, material handling
- Automotive assembling lines
- Automated warehousing

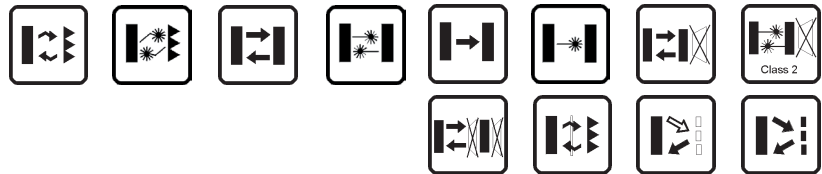

S90		
Through beam		0...20 m 0...60 m (class 1 LASER)
Polarized retroreflective		0...3,2 m (coaxial) 0,1...6,5 m 0,1...20 m (class 1 LASER)
Retroreflective for transparent (on R2 reflector)		0...1,7 m (coaxial)
Diffuse proximity		short 0,01...1 m long 0,05...2 m 0...600 mm (class 1 LASER)
Background suppression		70...200 mm 50...100 mm (class 1 LASER)
Foreground suppression		70...200 mm
Luminescence		0...40 mm
Contrast		19 ± 2 mm
Power supply	Vdc	10...30 V
	Vac	
	Vac/dc	
Output	PNP	▪
	NPN	▪
	NPN/PNP	
	relay	
	other	
	cable	
Connection	connector	▪
	pig-tail	
Approximate dimensions (mm)		15x50x41
Housing material		Zama
Mechanical protection		IP67

TECHNICAL DATA

Power supply	10 ... 30 Vdc (limit values)
Ripple	2 Vpp max.
Consumption (output current excluded)	35 mA max. 30 mA max. (mod. S90...B01/B51/C01/C11/F01/T51) 50 mA max. (mod. S90...W08/U08) 60 mA max. (Laser mod. S90...M08)
Light emission	red LED 660 nm (mod. S90...B01/B51/C01/T51) red LED 670 nm (mod. S90...M08) IR LED 880 nm (mod. S90...C11/G00) white LED 400-700 nm (mod. S90...W08) UV LED 370 nm (mod. S90...U08) red Laser 650 nm
Setting	sensitivity trimmer (mod. S90...B01/B51/C01/C11/F01/T51) SET push-button (mod. S90...M08/N03/W08/U08)
Operating mode	LIGHT mode on N.O. output/DARK mode on N.C. output (mod. S90...C01) DARK mode on N.O. output/LIGHT mode on N.C. output (mod. S90...B01/F01) LIGHT mode with EASY TOUCH™/automatic with fine detection (mod. S90...M08/N03/U08) DARK mode with EASY TOUCH/automatic with fine detection (mod. S90...W08)
Indicators	yellow OUTPUT LED (excl. mod. S90...G00) green STABILITY LED (mod. S90...B01/B51/C01/C11/F01), POWER LED (mod. S90...G00, Laser mod. S90...B01/C01/F01/G00) green/red READY/ERROR LED (mod. S90...M08/N03/W08/U08) yellow/orange OUTPUT LED, green/red LASER ON/ERROR LED (Laser mod. S90...M08)
Output	PNP or NPN; NO and NC (mod. S90...B01/C01/F01/T51)
Output current	100 mA max.
Saturation voltage	2 V max.
Response time	0,5 ms (mod. S90...B01/B51/T51) 1 ms (mod. S90...C01/C11/F01) 100 µs (mod. S90...W08) 500 µs max. (mod. S90...M08/N03) 250 µs (mod. S90...U08, Laser mod. S90...B01/C01) 333 µs (Laser mod. S90...F01)
Switching frequency	1 kHz (mod. S90...B01/B51/T51) 500 Hz (mod. S90...C01/C11/F01) 5 kHz (mod. S90...W08) 1 kHz (mod. S90...M08/N03) 2 kHz (mod. S90...U08, Laser mod. S90...B01/C01) 1,5 kHz (Laser mod. S90...F01)
Connection	M12 4-pole connector
Dielectric strength	500 Vac, 1 min between electronics and housing
Insulating resistance	>20 MΩ, 500 Vdc between electronics and housing
Electrical protection	class 2
Mechanical protection	IP67 (type 1 enclosure)
Ambient light rejection	according to EN 60947-5-2
Vibrations	0,5 mm amplitude, 10 ... 55 Hz frequency, for every axis (EN60068-2-6)
Shock resistance	11 ms (30 G) 6 shock for every axis (EN60068-2-27)
Housing material	ZAMA
Lens material	PMMA window and polycarbonate lens (mod. S90...B01/C01/C11/F01/G00/M08/N03) glass window and lens (mod. S90...B51/T51) glass window skewed anti-reflection and glass lens (mod. S90...W08/U08) PMMA window, polycarbonate and glass lens (Laser mod. S90...M08)
Operating temperature	-25 ... 55 °C (mod. S90...B01/B51/C01/C11/F01/G00) -10 ... 55 °C (mod. S90...M08/N03/W08/U08) -10 ... 50 °C (Laser mod.)
Storage temperature	-25 ... 70 °C (mod. S90...B01/B51/C01/C11/F01/G00, Laser mod. S90...B01/C01/F01/G00) -20 ... 70 °C (mod. S90...M08/N03/W08/U08, Laser mod. S90...M08)
Weight	77 g

COMPACT SENSORS

CONNECTIONS

M12 CONNECTOR

Through beam emitter

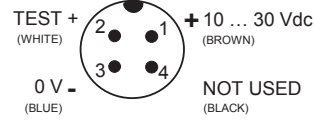
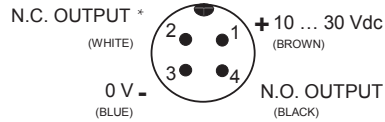

* N.C. OUTPUT (mod. S90...B, C, F, T), REMOTE (mod. S90...M, N, U, W)

INDICATORS AND SETTINGS

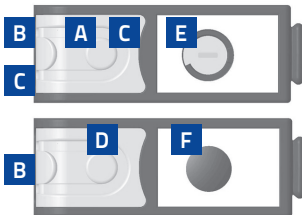

- A** STABILITY LED
- B** Output status LED
- C** POWER ON LED
- D** READY/ERROR LED
- E** Trimmer
- F** SET push-button *
- G** M12 connector output, orientable in 4 positions

* Teach-in push-button for setting.
EASYtouch™ provides two setting modes: standard or fine.
Please refer to instructions manual for operating details.

DIMENSIONS

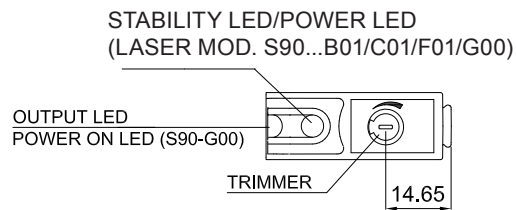
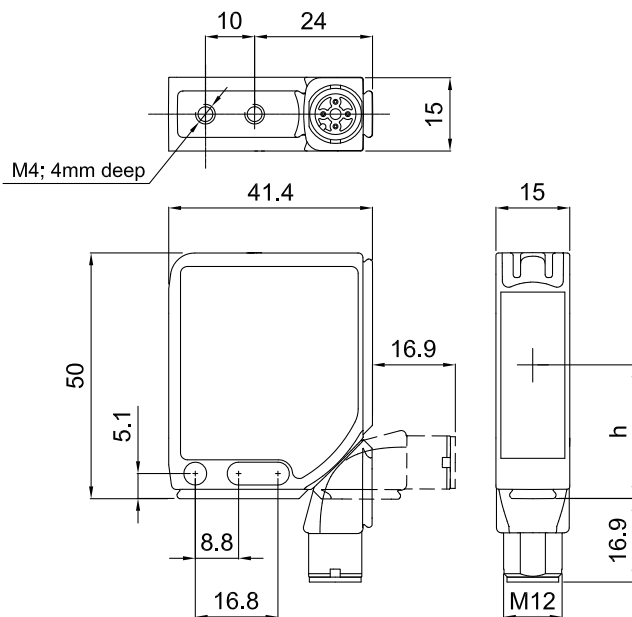

VERSION	h
B01 C01 C11 F01 G00	26.7
M08 N03	27.2
B51 T51 W08 U08	29.7

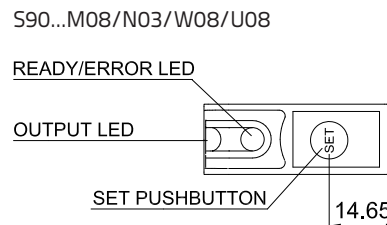

mm

DETECTION DIAGRAMS

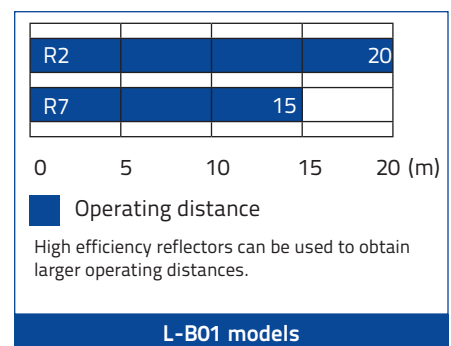
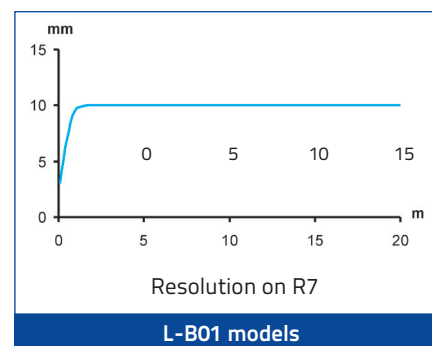
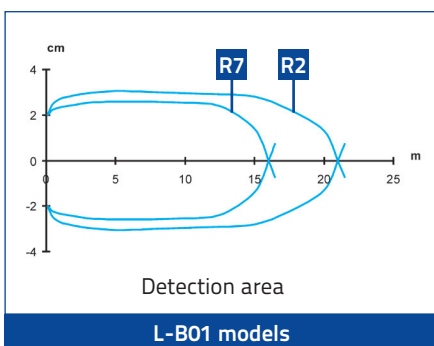
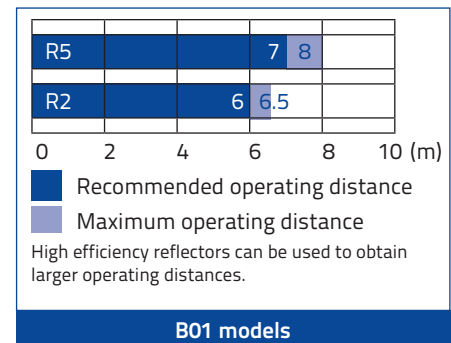
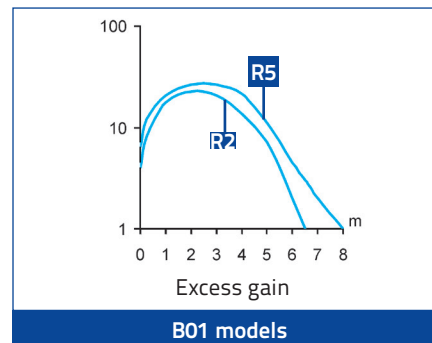
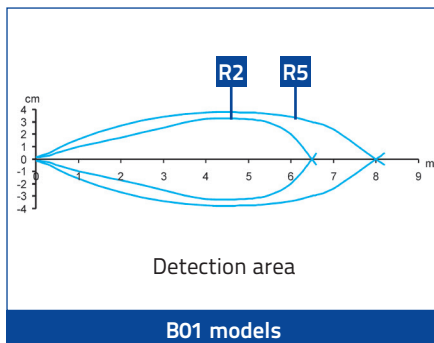
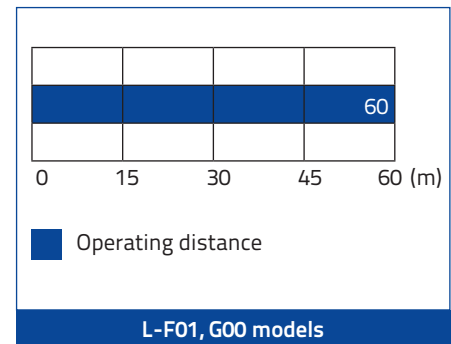
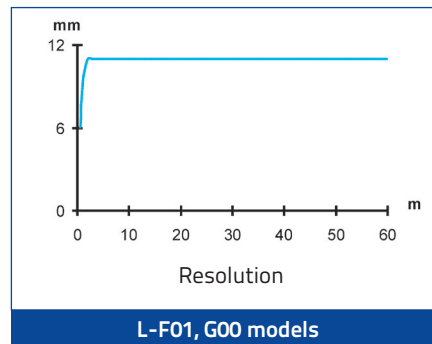
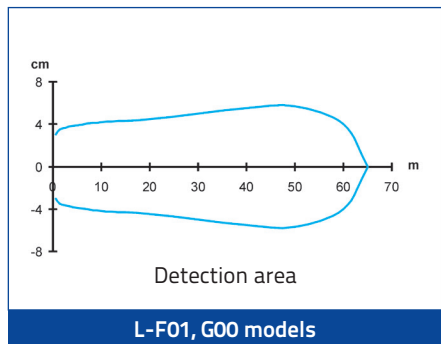
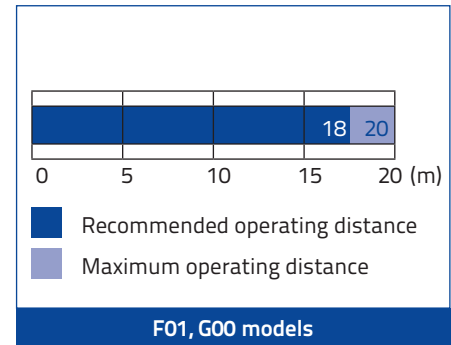
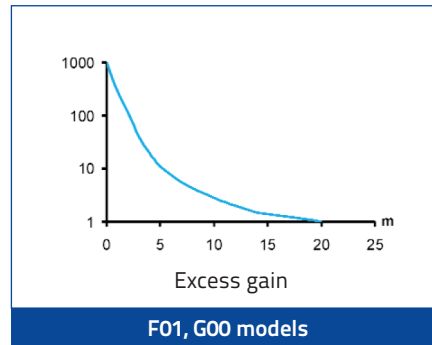
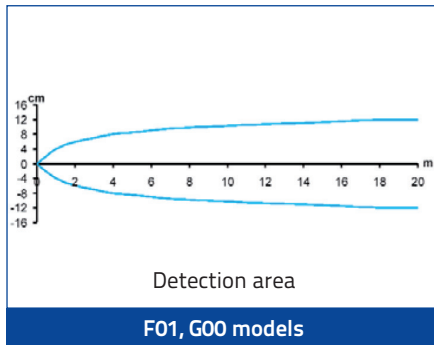

COMPACT SENSORS

DETECTION DIAGRAMS

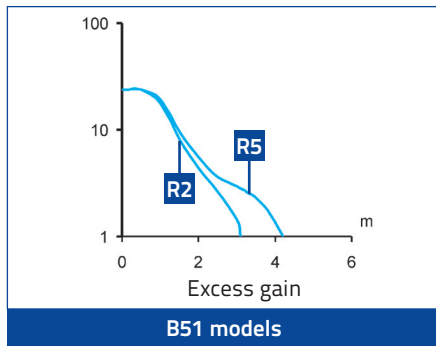
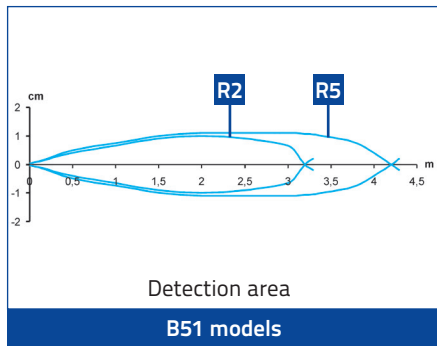

R5				4	5
R2			3	3.5	

0 1 2 3 4 5 (m)

■ Recommended operating distance
■ Maximum operating distance

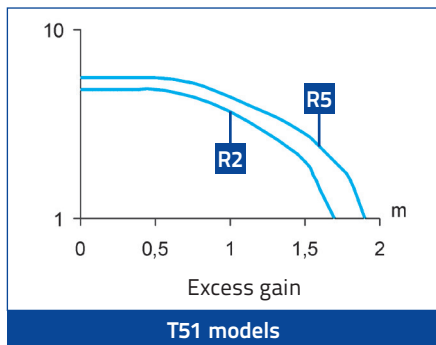
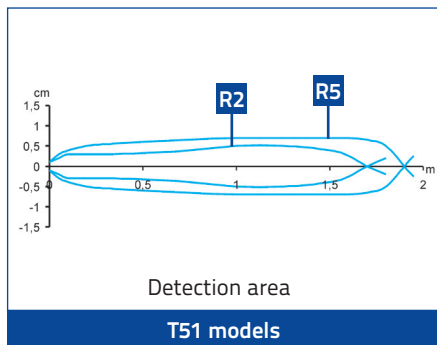

R5			1.7	2
R2			1.5	1.7

0 0.5 1 1.5 2 (m)

■ Recommended operating distance
■ Maximum operating distance

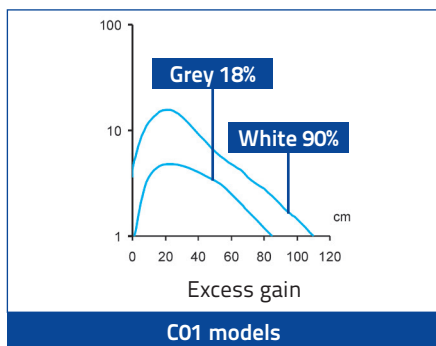
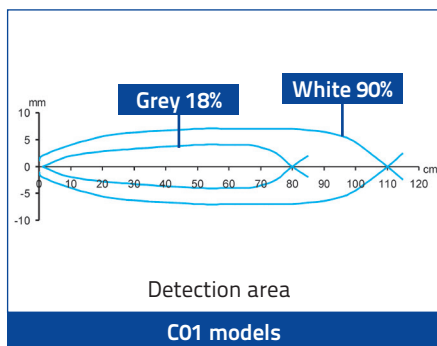

White			100	110
Grey			70	80

0 30 60 90 120 (cm)

■ Recommended operating distance
■ Maximum operating distance

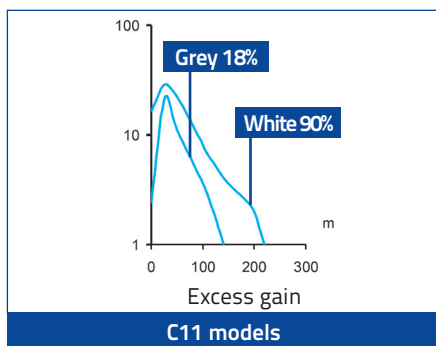
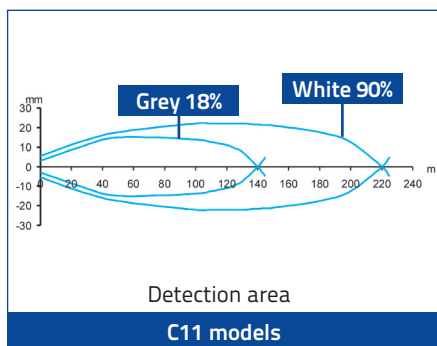

R5			2	2.2
R2			1.2	1.4

0 0.5 1 1.5 2 2.5 (m)

■ Recommended operating distance
■ Maximum operating distance

DETECTION DIAGRAMS

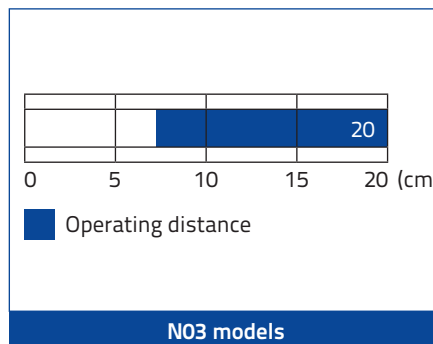
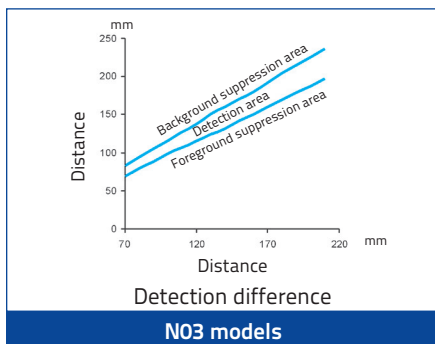
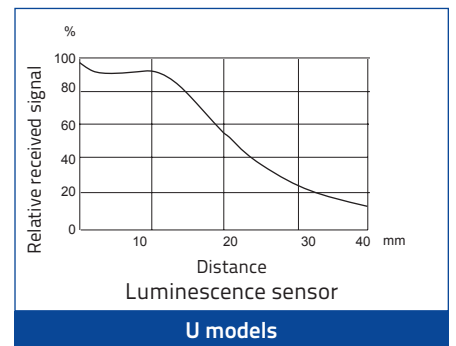
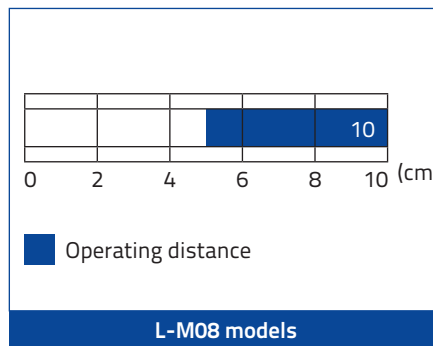
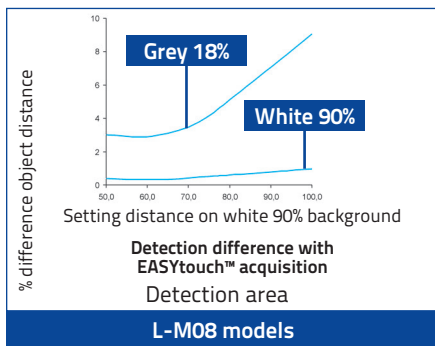
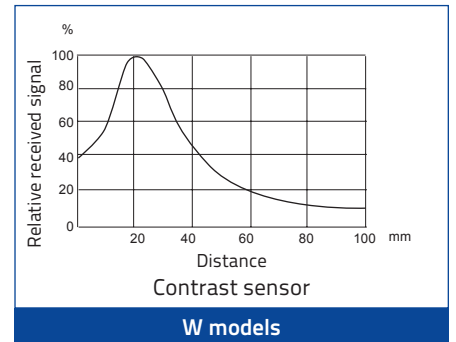
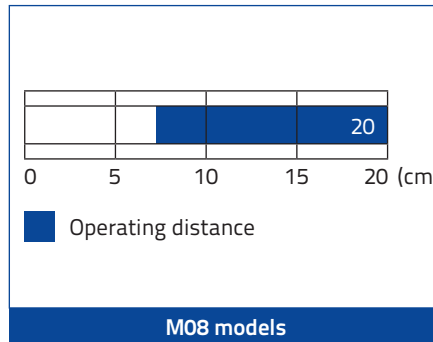
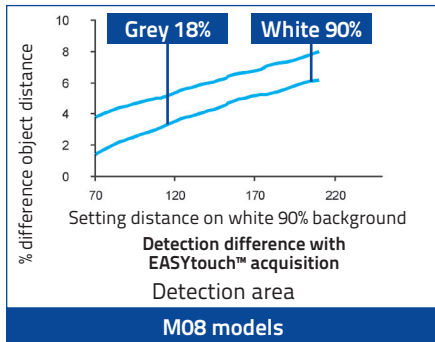
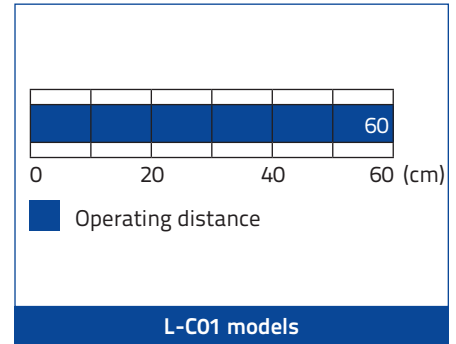
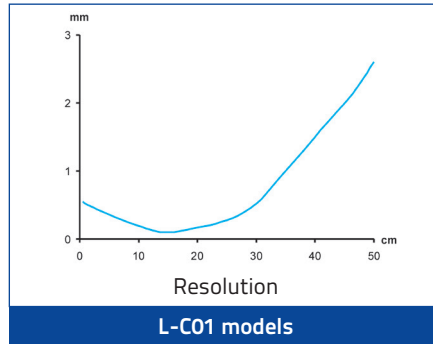
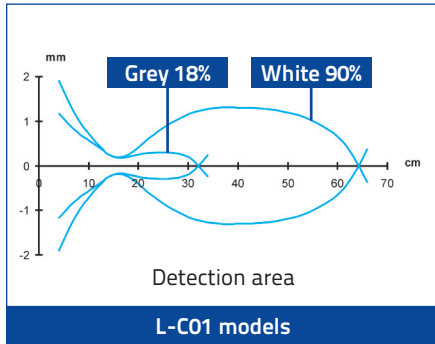

COMPACT SENSORS

MODEL SELECTION AND ORDER INFORMATION

OPTIC FUNCTION	EMISSION	SETTING	OUTPUT	MODEL	ORDER No.
Polarized retroreflective	LASER	Trimmer	NPN	S90-ML-5-B01-NN	956301260
			PNP	S90-ML-5-B01-PP	956301090
			NPN	S90-MA-5-B01-NN	956301160
Coaxial polarized retroreflective	LED	Trimmer	PNP	S90-MA-5-B01-PP	956301000
			NPN	S90-MA-5-B51-NN	956301170
			PNP	S90-MA-5-B51-PP	956301030
Short diffuse proximity	LASER	Trimmer	NPN	S90-ML-5-C01-NN	956301270
			PNP	S90-ML-5-C01-PP	956301100
			NPN	S90-MA-5-C01-NN	956301190
Long diffuse proximity	LED	Trimmer	PNP	S90-MA-5-C01-PP	956301010
			NPN	S90-MA-5-C11-NN	956301200
			PNP	S90-MA-5-C11-PP	956301020
Through beam receiver	LASER	Trimmer	NPN	S90-ML-5-F01-NN	956301280
			PNP	S90-ML-5-F01-PP	956301110
			NPN	S90-MA-5-F01-NN	956301210
Through beam emitter	LED	-	PNP	S90-MA-5-F01-PP	956301050
			-	S90-ML-5-G00-XG	956301120
			-	S90-MA-5-G00-XG	956301060
Background suppression	LASER	Teach-in, delay-off, remote	NPN	S90-ML-5-M08-NH	956301290
			PNP	S90-ML-5-M08-PH	956301130
			NPN	S90-MA-5-M08-NH	956301220
Background and foreground suppression	LED	Teach-in, delay-off, remote	PNP	S90-MA-5-M08-PH	956301070
			NPN	S90-MA-5-N03-NH	956301230
			PNP	S90-MA-5-N03-PH	956301080
Retroreflective for transparent	LED	Trimmer	NPN	S90-MA-5-T51-NN	956301180
			PNP	S90-MA-5-T51-PP	956301040
			NPN	S90-MA-5-U08-NH	956301240
Luminescence	LED	Teach-in, delay-off, remote	PNP	S90-MA-5-U08-PH	956301140
			NPN	S90-MA-5-W08-NH	956301250
			PNP	S90-MA-5-W08-PH	956301150

ACCESSORIES

ST-5018

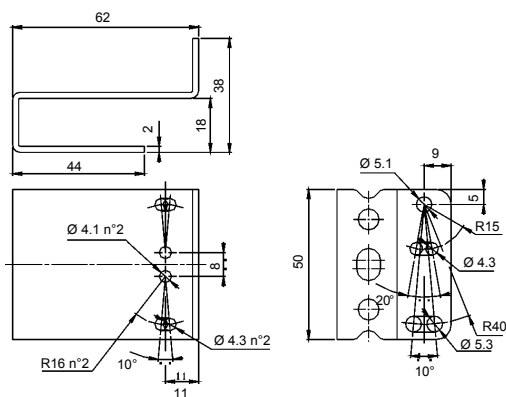

ST-5019

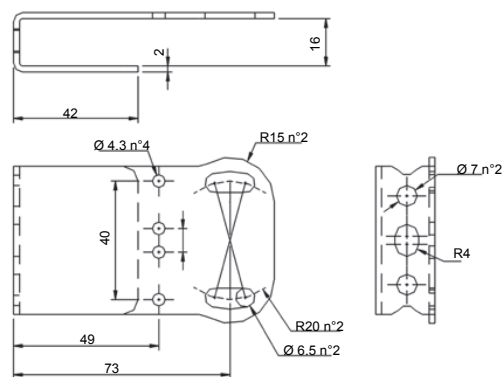

JOINT-60

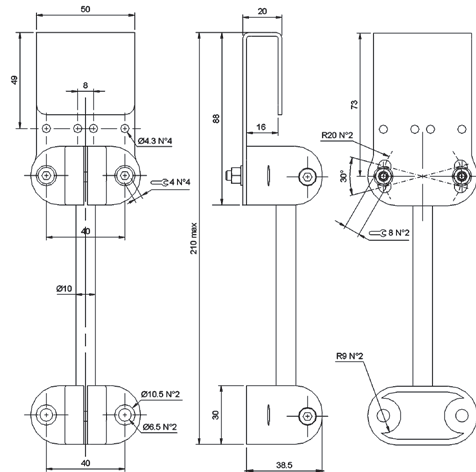

ST-5020

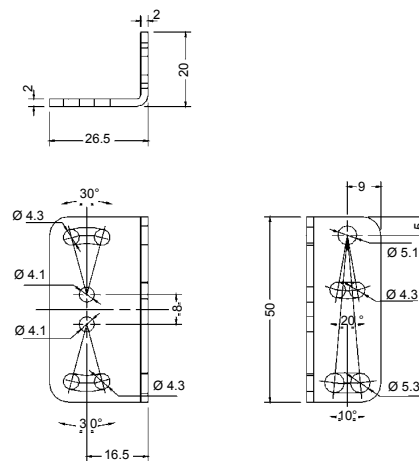



ST-5021

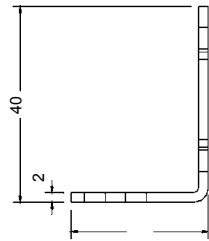
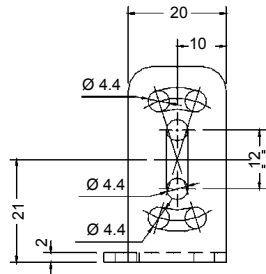
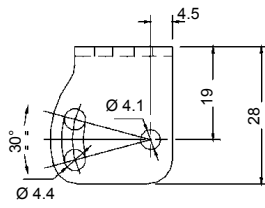

ST-504

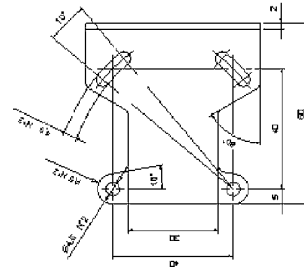
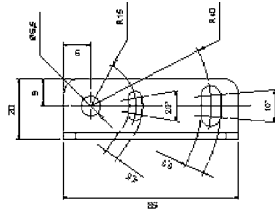

ST-5053

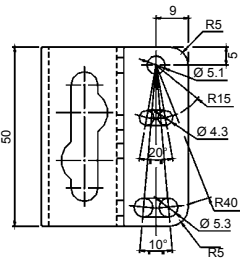
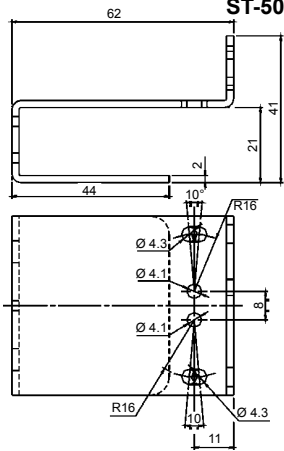

ST-5054

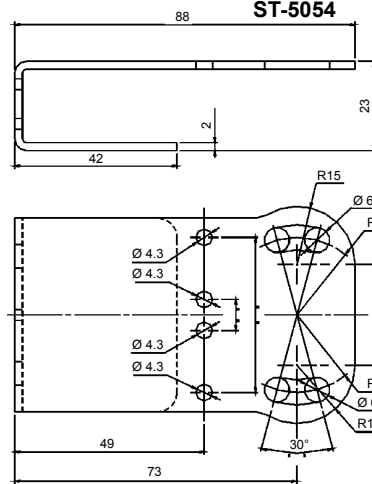

ST-5041

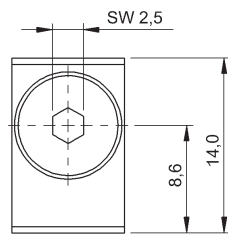
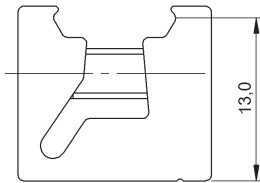
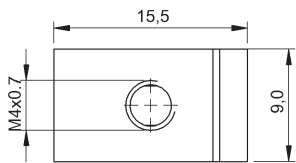

ST-5042

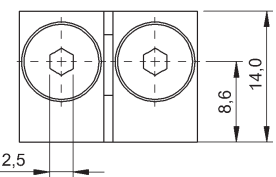
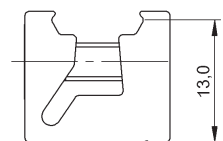
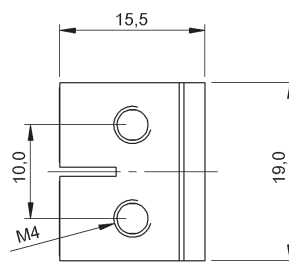

COMPACT SENSORS

MODEL	DESCRIPTION	ORDER No.
ST-5018	protective bracket	95ACC5310
ST-5019	protective bracket	95ACC5320
ST-5020	mounting bracket	95ACC5330
ST-5021	mounting bracket	95ACC5340
ST-504	mounting bracket	95ACC2820
ST-5053	protective bracket	95ACC2410
ST-5054	protective bracket	95ACC2420
ST-5041	short dove-tail bracket	95ACC2300
ST-5042	long dove-tail bracket	95ACC2310
JOINT -60	protective bracket with jointed support	95ACC 5350

CABLES

TYPE	DESCRIPTION	LENGTH	MODEL	ORDER No.
Axial M12 Connector	4-pole, grey, P.V.C.	3 m	CS-A1-02-G-03	95A251380
		5 m	CS-A1-02-G-05	95A251270
		7 m	CS-A1-02-G-07	95A251280
		10 m	CS-A1-02-G-10	95A251390
	4-pole, P.U.R.	2 m	CS-A1-02-R-02	95A251540
		5 m	CS-A1-02-R-05	95A251560
Radial M12 Connector	4-pole, grey, P.V.C.	3 m	CS-A2-02-G-03	95A251360
		5 m	CS-A2-02-G-05	95A251240
		7 m	CS-A2-02-G-07	95A251245
		10 m	CS-A2-02-G-10	95A251260
	4-pole, P.U.R.	2 m	CS-A2-02-R-02	95A251550
		5 m	CS-A2-02-R-05	95A251570
Radial M12 Connector with LED (for PNP N.O. sensors)	4-pole, grey, P.V.C.	3 m	CS-A2-12-G-03	95A251400
		5 m	CS-A2-12-G-05	95A251350
		10 m	CS-A2-12-G-10	95A251370
Axial M12 Connector	4-pole, shielded, black, P.V.C.	3 m	CV-A1-22-B-03	95ACC1480
		5 m	CV-A1-22-B-05	95ACC1490
		10 m	CV-A1-22-B-10	95ACC1500
		15 m	CV-A1-22-B-15	95ACC2070
		25 m	CV-A1-22-B-25	95ACC2090
Radial M12 Connector	4-pole, shielded, black, P.V.C.	3 m	CV-A2-22-B-03	95ACC1540
		5 m	CV-A2-22-B-05	95ACC1550
		10 m	CV-A2-22-B-10	95ACC1560
Axial M12 Connector	4-pole, U.L., black, P.V.C.	3 m	CS-A1-02-U-03	95ASE1120
		5 m	CS-A1-02-U-05	95ASE1130
		10 m	CS-A1-02-U-10	95ASE1140
		15 m	CS-A1-02-U-15	95ASE1150
		25 m	CS-A1-02-U-25	95ASE1160
Radial M12 Connector	4-pole, black	Connector- not cabled	CS-A1-02-B-NC	G5085002
		Connector- not cabled	CS-A2-02-B-NC	G5085003



MAXI SENSORS

S300 PA

Advanced MAXI photoelectric multivoltage sensors

- Industrial plastic housing with IP67 mechanical protection
- Timing function from 0.6-16 s ON delay, OFF delay and ONE SHOT
- Terminal block for both Vdc and Vac/ Vdc free voltage
- Distance trimmer for mechanical background suppression models



APPLICATIONS

- Packaging end of line, palletizers
- Outdoor or indoor gates control
- Manufacturing plants



(*)DC models:
ATEX II 3DG

S300 PA		
Through beam		0...50 m
Retroreflective (on R2 reflector)		0,1...15 m
Polarized retroreflective		0,1...10 m
Diffuse proximity		0,05...2 m
Background suppression		0,2...2 m
Power supply	Vdc	12...30 V
	Vac	
	Vac/dc	24...240 Vac/24...60 Vdc
Output	PNP	
	NPN	
	NPN/PNP	▪
	relay	▪
Connection	other	
	cable	
	connector	▪
	pig-tail	
Approximate dimensions (mm)		25x100x70
Housing material		PBT
Mechanical protection		IP67

TECHNICAL DATA

Power supply	12 ... 30 Vdc (mod. S300...2) 24...240 Vac/24...60 Vdc (mod. S300...1)
Ripple	10% max.
Consumption (output current excluded)	35 mA max. (mod. S300...2) 3 VA max. (mod. S300...1)
Light emission	red LED 660 nm (mod. S300...B) IR LED 940 nm (mod. S300...C) IR LED 880 nm (mod. S300...A/G/M)
Setting	sensitivity trimmer (mod. S300...A/B/C/F), DARK/LIGHT dip-switch (mod. S300...A/B/C/F/M) 7-turns distance adjustment trimmer (mod. S300...M) dip-switch mode ON delay/OFF delay/ON-OFF delay/single pulse (ONE-SHOT) (mod. S300...x06) timing trimmer (mod. S300...x06)
Indicators	yellow OUTPUT LED (excl. mod. S300...G) green STABILITY LED, POWER LED (mod. S300...G)
Output	PNP or NPN open collector (mod. S300...2); electromechanical SPDT 250 Vac/30 Vdc (mod. S300...1)
Output current	100 mA (mod. S300...2) 3 A max. (mod. S300...1)
Saturation voltage	2,4 V max.
Response time	1 ms (mod. S300...2-A/B/C/M) 2 ms (mod. S300...2-F/G) 25 ms (mod. S300...1)
Switching frequency	500 Hz (mod. S300...2-A/B/C/M) 250 Hz (mod. S300...2-F/G) 20 Hz max. (mod. S300...1)
Connection	terminal block
Dielectric strength	500 Vac, 1 min between electronics and housing
Insulating resistance	>20 MΩ, 500 Vdc between electronics and housing
Electrical protection	class 2 (mod. S300...2)
Mechanical protection	IP67 (IEC/EN60529)
Ambient light rejection	according to EN 60947-5-2
Vibrations	0,5 mm amplitude, 10 ... 55 Hz frequency, for every axis (EN60068-2-6)
Shock resistance	11 ms (30 G) 6 shock for every axis (EN60068-2-27)
Housing material	PBT 30% glass fiber-reinforced
Lens material	frontal window and lens in PC
Operating temperature	-25 ... 55 °C
Storage temperature	-25 ... 70 °C
Weight	120 g (mod. S300...2), 130 g (mod. S300...1)

DIMENSIONS

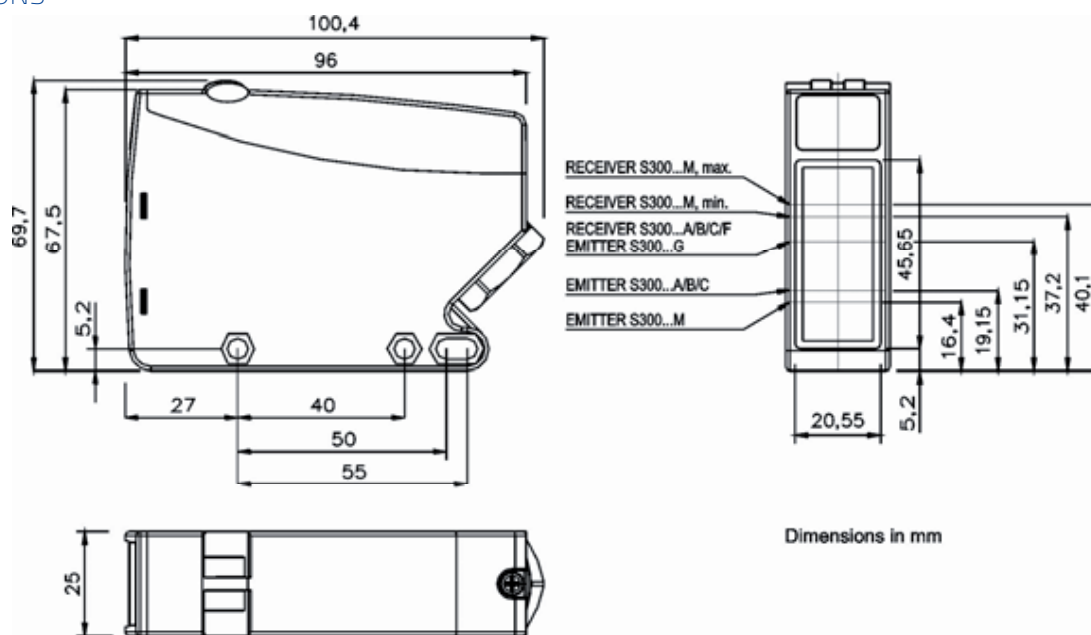

MAXI SENSORS

CONNECTIONS

VAC MODELS

Through beam emitter

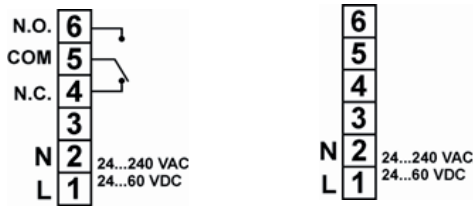

VDC MODELS

Through beam emitter



INDICATORS AND SETTINGS

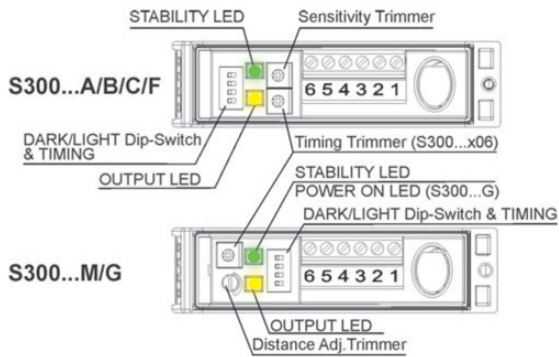

SETTINGS

The **M** model presents a **multiturn adjustment screw** for the adjustment of the background suppression distance using a mechanical variation of the optic triangulation angle. The **other models** have a **mono-turn electronic trimmer** that adjusts the sensitivity and the sensor operating distance. The operating distance can be increased by rotating the screws clockwise. Trimmers can be used to adjust the output activation and deactivation delay time whilst functioning mode selection is performed through DIP SWITCHES.

DETECTION DIAGRAMS

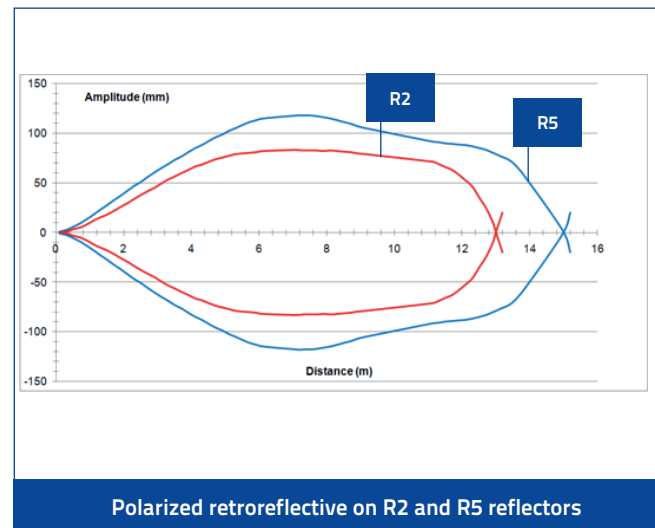
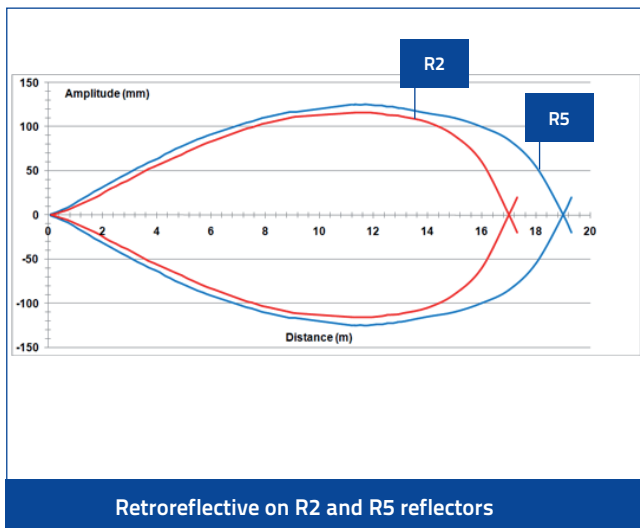

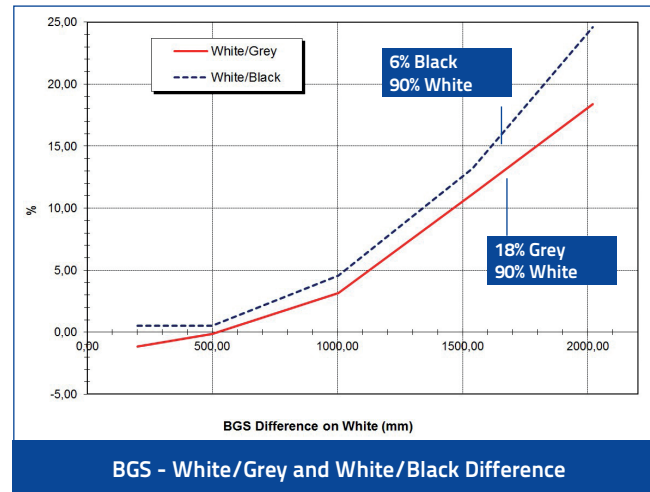
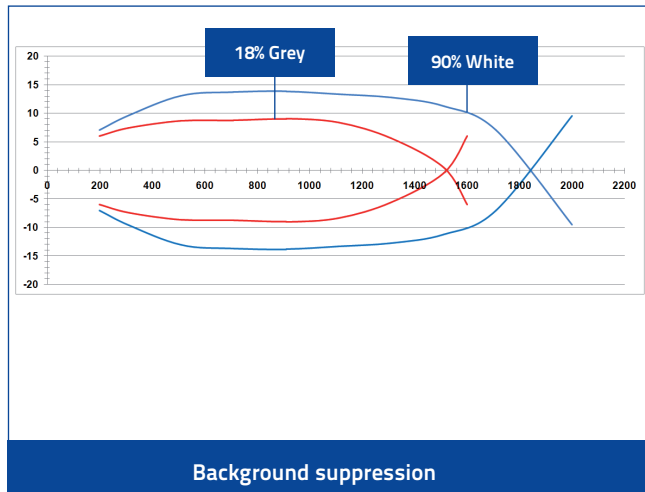
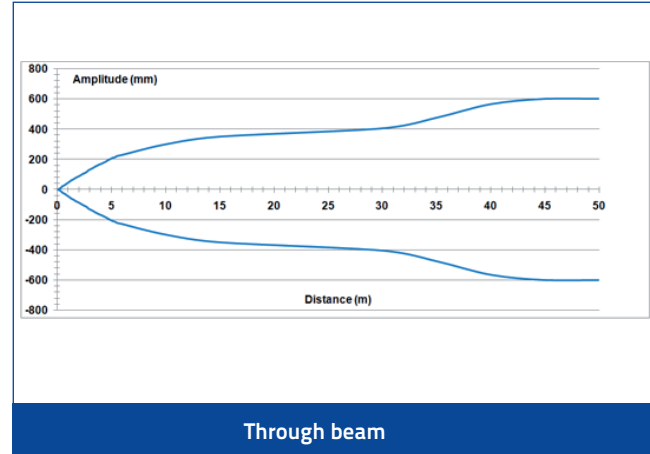
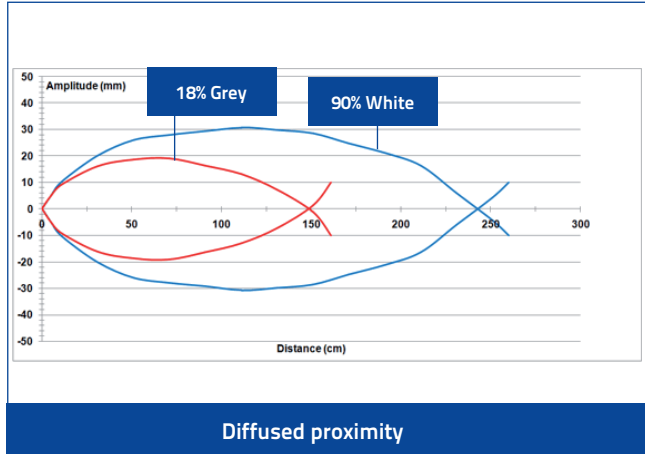

MODEL SELECTION AND ORDER INFORMATION

OPTIC FUNCTION	POWER SUPPLY	OUTPUT	SETTING	MODEL	ORDER No.
Retroreflective (IR LED 880 nm)	12...30 Vdc	NPN/PNP	Sensitivity trimmer and D/L dip-switch	S300-PA-2-A01-OC	951451500
			Timing and sensitivity trimmers, D/L dip-switch	S300-PA-2-A06-OC	951451510
	24...240 Vac/24...60 Vdc	Relay	Sensitivity trimmer and D/L dip-switch	S300-PA-1-A01-RX	951451480
			Timing and sensitivity trimmers, D/L dip-switch	S300-PA-1-A06-RX	951451490
Polarized retroreflective (red LED 660 nm)	12...30 Vdc	NPN/PNP	Sensitivity trimmer and D/L dip-switch	S300-PA-2-B01-OC	951451540
			Timing and sensitivity trimmers, D/L dip-switch	S300-PA-2-B06-OC	951451550
	24...240 Vac/24...60 Vdc	Relay	Sensitivity trimmer and D/L dip-switch	S300-PA-1-B01-RX	951451520
			Timing and sensitivity trimmers, D/L dip-switch	S300-PA-1-B06-RX	951451530
Diffused proximity (IR LED 940 nm)	12...30 Vdc	NPN/PNP	Sensitivity trimmer D/L dip-switch	S300-PA-2-C01-OC	951451420
			Timing and sensitivity trimmers, D/L dip-switch	S300-PA-2-C06-OC	951451430
	24...240 Vac/24...60 Vdc	Relay	Sensitivity trimmer and D/L dip-switch	S300-PA-1-C01-RX	951451400
			Timing and sensitivity trimmers, D/L dip-switch	S300-PA-1-C06-RX	951451410
Through beam receiver	12...30 Vdc	NPN/PNP	Sensitivity trimmer and D/L dip-switch	S300-PA-2-F01-OC	951451600
			Timing and sensitivity trimmers, D/L dip-switch	S300-PA-2-F06-OC	951451610
	24...240 Vac/24...60 Vdc	Relay	Sensitivity trimmer and D/L dip-switch	S300-PA-1-F01-RX	951451580
			Timing and sensitivity trimmers, D/L dip-switch	S300-PA-1-F06-RX	951451590
Through beam emitter (IR LED 880 nm)	12...30 Vdc	-	-	S300-PA-2-G00-EX	951451570
	24...240 Vac/24...60 Vdc	-	-	S300-PA-1-G00-EX	951451560
Background suppression (IR LED 880 nm)	12...30 Vdc	NPN/PNP	7-turns distance adjustment trimmer and /L dip-switch	S300-PA-2-M01-OC	951451460
			Timing and 7-turns distance adj. trimmers, D/L dip-switch	S300-PA-2-M06-OC	951451470
	24...240 Vac/24...60 Vdc	Relay	7-turns distance adjustment trimmer and D/L dip-switch	S300-PA-1-M01-RX	951451440
			Timing and 7-turns distance adj. trimmers, D/L dip-switch	S300-PA-1-M06-RX	951451450

MAXI SENSORS

ACCESSORIES

ST-511

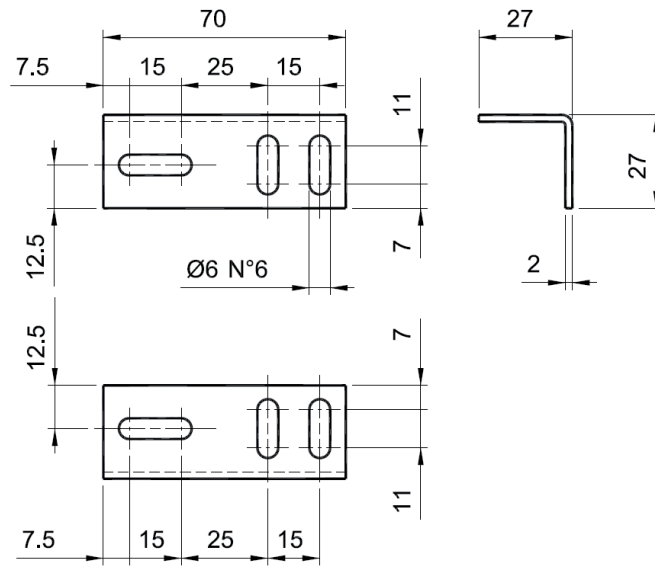

MODEL	DESCRIPTION	ORDER No.
ST-511	mounting bracket	95ACC2810



MAXI SENSORS

S300 PR

Heavy duty sensor for outdoor applications and harsh environments

- Industrial plastic housing with IP67 mechanical protection
- Defogging system function
- Double independent timing functions with double time scale from 0-2s or 0-10s, One-Delay, Off Delay, ONE SHOT



APPLICATIONS

- Packaging end of line, palletizers
- Outdoor or indoor gates control
- Automotive plants
- Automated warehousing

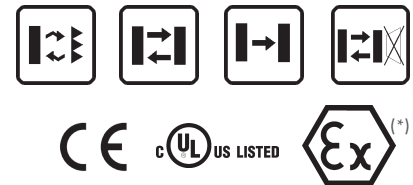

(*):DC models:
ATEX II 3DG

S300 PA		
Through beam		0...60 m
Polarized retroreflective		0,1...22 m
Diffuse proximity		0,05...5 m
Background suppression		0,4...2,5 m
Power supply	Vdc	10...30 V
	Vac	
	Vac/dc	24...240 Vac / 24...60 Vdc
Output	PNP	
	NPN	
	NPN/PNP	▪
	relay	▪
	other	
Connection	cable	
	connector	▪
	pig-tail	
Approximate dimensions (mm)		25x100x70
Housing material		PBT
Mechanical protection		IP67

TECHNICAL DATA

Power supply	10 ... 30 Vdc (mod. S300...2/5) 24...240 Vac/24...60 Vdc (mod. S300...1)
Ripple	10% max.
Consumption (output current excluded)	30 mA max. (mod. S300...2/5-B/C) 35 mA max. (mod. S300...2/5-M) 25 mA max. (mod. S300...2/5-F) 20 mA max. (mod. S300...2/5-G) 3 VA max. (mod. S300...1)
Light emission	red LED 660 nm (mod. S300...B) IR LED 880 nm (mod. S300...C/G/M)
Setting	sensitivity trimmer, DARK/LIGHT trimmer (mod. S300...F/C/B) 15 turns adjustment screw/DARK/LIGHT trimmer (mod. S300...M) emission power regulation trimmer (mod. S300...G) versions with timing functions: time base selection and one shot trimmer/ON DELAY trimmer/OFF DELAY trimmer (mod. S300...x06)
Indicators	yellow OUTPUT LED (excl. mod. S300...G) green STABILITY LED, POWER LED (mod. S300...G)
Output	PNP or NPN open collector (mod. S300...2/5); Electromechanical SPDT 250 Vac/30 Vdc (mod. S300...1)
Output current	100 mA (mod. S300...2/5) 3 A max. (mod. S300...1)
Saturation voltage	2,4 V max.
Response time	1 ms (mod. S300...2/5-B/C/F/G) 2 ms (mod. S300...2/5-M) 20 ms (mod. S300...1)
Switching frequency	500 Hz (mod. S300...2/5-/B/C/F/G) 250 Hz (mod. S300...2/5-M) 25 Hz (mod. S300...1)
Connection	terminal block, M12 4-pole connector (only DC mod.)
Dielectric strength	500 Vac, 1 min between electronics and housing
Insulating resistance	>20 MΩ, 500 Vdc between electronics and housing
Electrical protection	class 2 (mod. S300...2/5)
Mechanical protection	IP67 (IEC/EN60529)/cable gland EN50262
Ambient light rejection	according to EN 60947-5-2
Vibrations	0,5 mm amplitude, 10 ... 55 Hz frequency, for every axis (EN60068-2-6)
Shock resistance	11 ms (30 G) 6 shock for every axis (EN60068-2-27)
Housing material	PBT 30% glass fiber-reinforced
Lens material	frontal window and lens in PC
Operating temperature	-40 ... 55 °C
Storage temperature	-40 ... 70 °C
Weight	140 g (mod. S300...2/5), 150 g (mod. S300...1)

DIMENSIONS

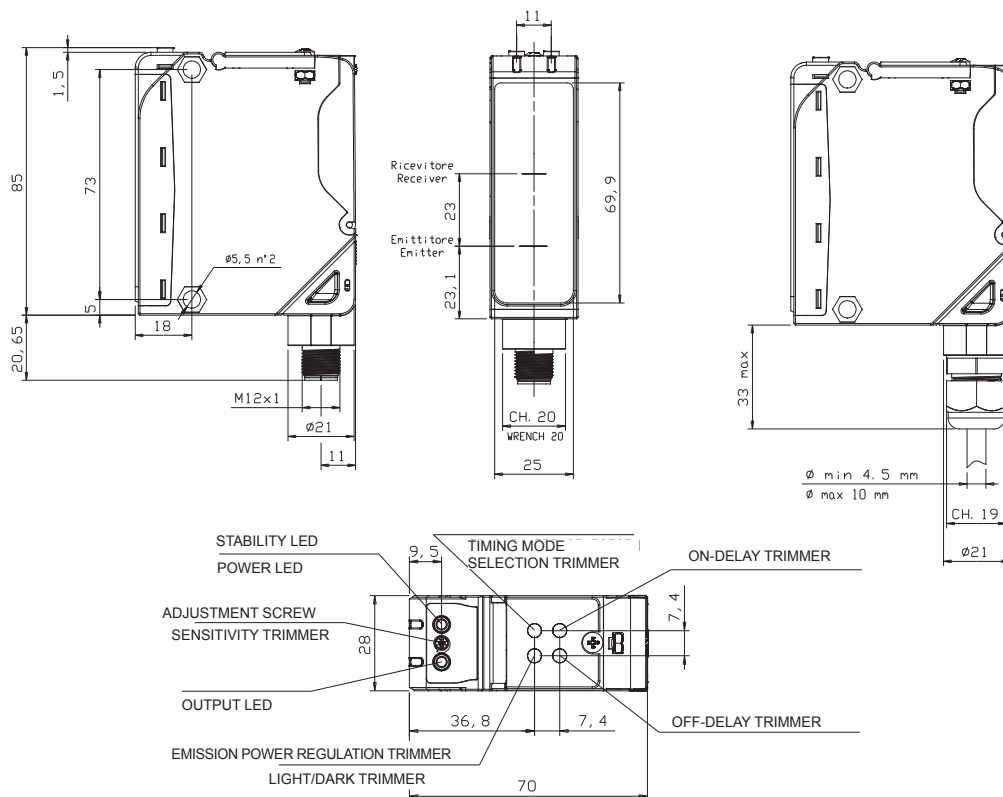

MAXI SENSORS

INDICATORS AND SETTINGS

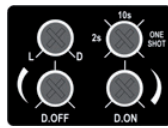
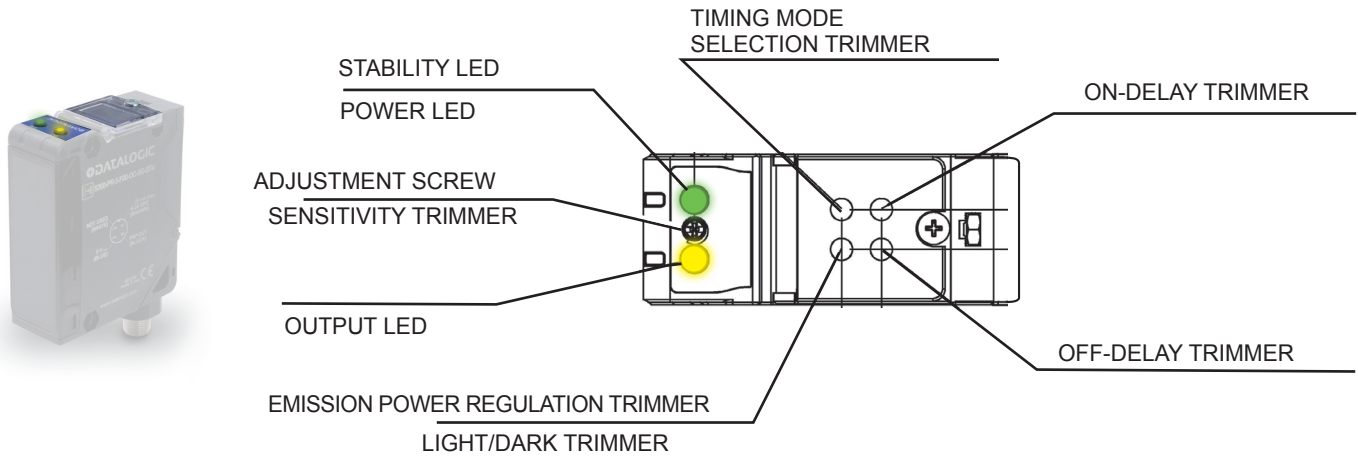

CONNECTIONS

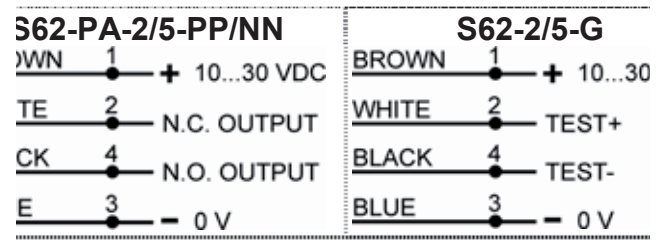
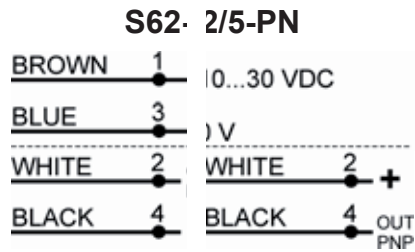

Through beam emitter

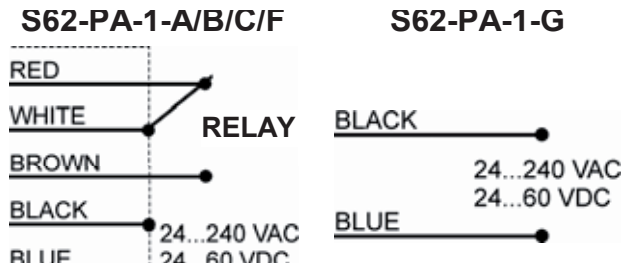

DETECTION DIAGRAMS

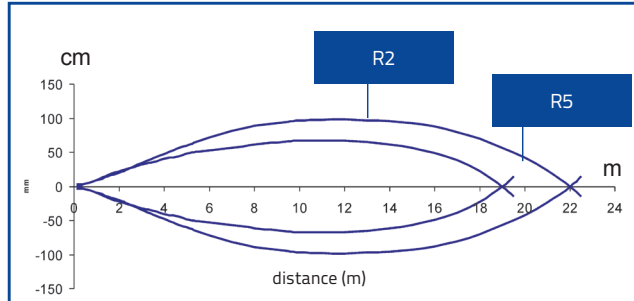

Polarized retroreflective on R2 reflector

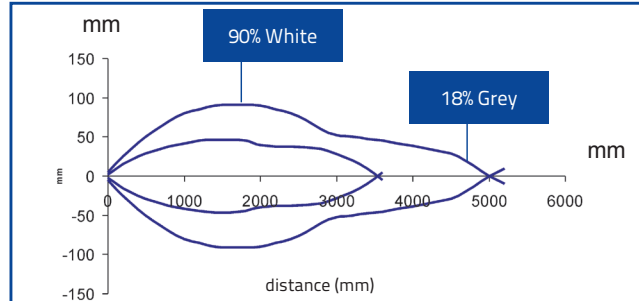

Diffuse proximity

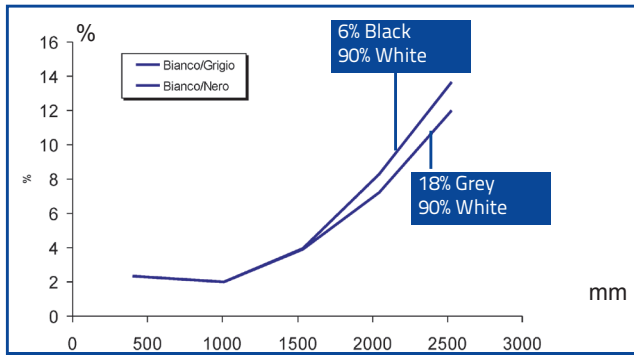

Background suppression

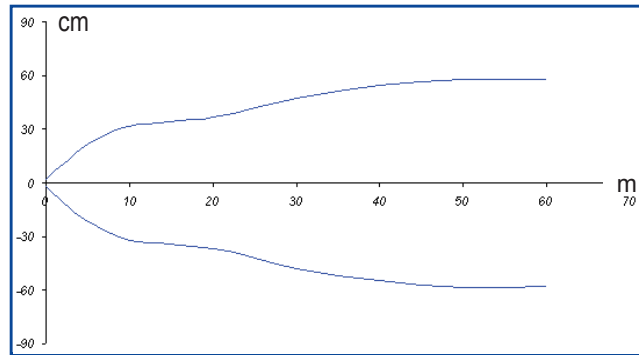

Through beam

MODEL SELECTION AND ORDER INFORMATION

OPTIC FUNCTION	OUTPUT	CONNECTION	SETTING	MODEL	ORDER No.
Polarized retroreflective	NPN/PNP	Vdc - Terminal block	Sensitivity and D/L trimmers	S300-PR-2-B01-OC	951451000
			Timing, sensitivity and D/L trimmers	S300-PR-2-B06-OC	951451010
		Vdc - M12 Connector	Sensitivity and D/L trimmers	S300-PR-5-B01-OC	951451020
			Timing, sensitivity and D/L trimmers	S300-PR-5-B06-OC	951451030
	Relay	Vac - Terminal block	Sensitivity and D/L trimmers	S300-PR-1-B01-RX	951451040
			Timing, sensitivity and D/L trimmers	S300-PR-1-B06-RX	951451050
Diffused proximity	NPN/PNP	Vdc - Terminal block	Sensitivity and D/L trimmers	S300-PR-2-C01-OC	951451070
			Timing, sensitivity and D/L trimmers	S300-PR-2-C06-OC	951451080
		Vdc - M12 Connector	Sensitivity and D/L trimmers	S300-PR-5-C01-OC	951451090
			Timing, sensitivity and D/L trimmers	S300-PR-5-C06-OC	951451100
	Relay	Vac - Terminal block	Sensitivity and D/L trimmers	S300-PR-1-C01-RX	951451110
			Timing, sensitivity and D/L trimmers	S300-PR-1-C06-RX	951451120
			Timing, sensitivity and D/L trimmers; defogging function	S300-PR-1-C06-RX-M	951451130
		Vac - Terminal block	Sensitivity and D/L trimmers	S300-PR-2-F01-OC	951451210
			Timing, sensitivity and D/L trimmers	S300-PR-2-F06-OC	951451220
			Sensitivity and D/L trimmers	S300-PR-5-F01-OC	951451230
Through beam receiver	NPN/PNP	Vdc - Terminal block	Sensitivity and D/L trimmers	S300-PR-5-F06-OC	951451240
			Timing, sensitivity and D/L trimmers	S300-PR-5-F06-OC	951451240
		Vdc - M12 Connector	Sensitivity and D/L trimmers	S300-PR-1-F01-RX	951451250
	Timing, sensitivity and D/L trimmers		S300-PR-1-F06-RX	951451260	
	Timing, sensitivity and D/L trimmers; defogging function		S300-PR-1-F06-RX-M	951451270	
	Through beam emitter	-	Vdc - Terminal block	Sensitivity and D/L trimmers	S300-PR-2-G00-EX
Emission power regulation trimmer				S300-PR-5-G00-EX	951451290
Vdc - M12 Connector			Sensitivity and D/L trimmers	S300-PR-1-G00-EX	951451300
			Defogging function	S300-PR-1-G00-EX-M	951451310
Background suppression	NPN/PNP	Vdc - Terminal block	Sensitivity and D/L trimmers	S300-PR-2-M01-OC	951451140
			Timing, sensitivity and D/L trimmers	S300-PR-2-M06-OC	951451150
		Vdc - M12 Connector	Sensitivity and D/L trimmers	S300-PR-5-M01-OC	951451160
			Timing, sensitivity and D/L trimmers	S300-PR-5-M06-OC	951451170
	Relay	Vac - Terminal block	Sensitivity and D/L trimmers	S300-PR-1-M01-RX	951451180
			Timing, sensitivity and D/L trimmers	S300-PR-1-M06-RX	951451190
		Vac - Terminal block	Sensitivity and D/L trimmers	S300-PR-1-M06-RX-M	951451200
			Timing, sensitivity and D/L trimmers; defogging function	S300-PR-1-M06-RX-M	951451200

MAXI SENSORS

ACCESSORIES

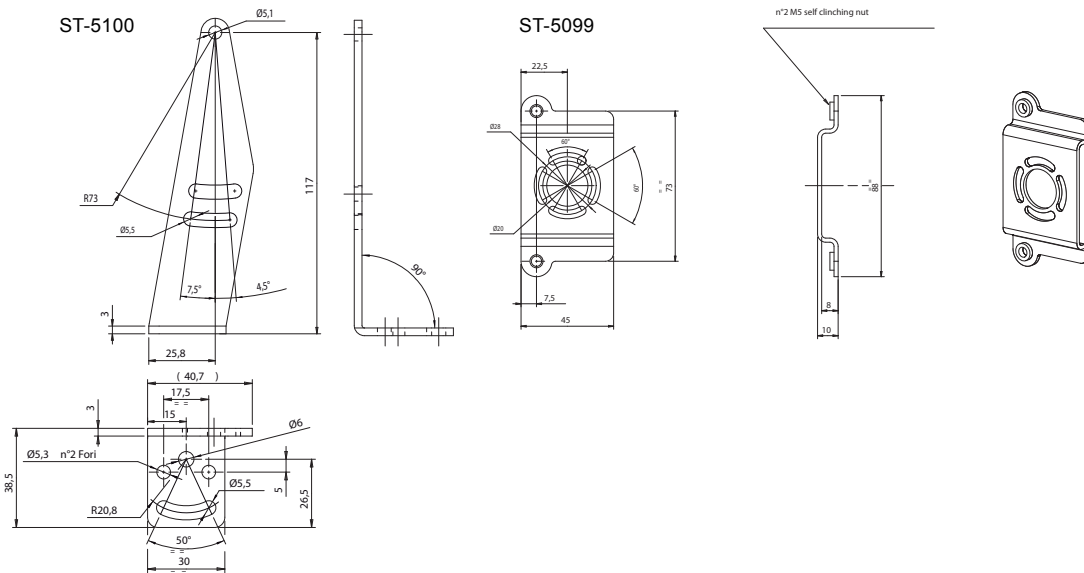

MODEL	DESCRIPTION	ORDER No.
ST-5099	mounting BRACKET	95ACC2830
ST-5100	mounting BRACKET	95ACC2840

CABLES

TYPE	DESCRIPTION	LENGTH	MODEL	ORDER No.
Axial M12 Connector	4-pole, grey, P.V.C.	3 m	CS-A1-02-G-03	95A251380
		5 m	CS-A1-02-G-05	95A251270
		7 m	CS-A1-02-G-07	95A251280
		10 m	CS-A1-02-G-10	95A251390
	4-pole, P.U.R.	2 m	CS-A1-02-R-02	95A251540
		5 m	CS-A1-02-R-05	95A251560
Radial M12 Connector	4-pole, grey, P.V.C.	3 m	CS-A2-02-G-03	95A251360
		5 m	CS-A2-02-G-05	95A251240
		7 m	CS-A2-02-G-07	95A251245
		10 m	CS-A2-02-G-10	95A251260
	4-pole, P.U.R.	2 m	CS-A2-02-R-02	95A251550
		5 m	CS-A2-02-R-05	95A251570
Axial M12 Connector	4-pole, shielded, black, P.V.C.	3 m	CV-A1-22-B-03	95ACC1480
		5 m	CV-A1-22-B-05	95ACC1490
		10 m	CV-A1-22-B-10	95ACC1500
		15 m	CV-A1-22-B-15	95ACC2070
Radial M12 Connector	4-pole, shielded, black, P.V.C.	25 m	CV-A1-22-B-25	95ACC2090
		3 m	CV-A2-22-B-03	95ACC1540
		5 m	CV-A2-22-B-05	95ACC1550
		10 m	CV-A2-22-B-10	95ACC1560
Axial M12 Connector	4-pole, U.L., black, P.V.C.	3 m	CS-A1-02-U-03	95ASE1120
		5 m	CS-A1-02-U-05	95ASE1130
		10 m	CS-A1-02-U-10	95ASE1140
		15 m	CS-A1-02-U-15	95ASE1150
		25 m	CS-A1-02-U-25	95ASE1160
Radial M12 Connector	4-pole, black	Connector- not cabled	CS-A1-02-B-NC	G5085002
		Connector- not cabled	CS-A2-02-B-NC	G5085003



FIBER OPTIC SENSORS

S7

Fiber optic amplifiers in a DIN rail compatible format for small object detection in limited spaces

- High-resolution models with integrated display
- 12 bit resolution and 50 μ s response time
- Trimmer or teach-in models
- Wide range of accessory fiber optics
- 4 wire NO/NC output or Remote teach input

APPLICATIONS

- Processing and Packaging machinery
- Electronics assembling
- Pharmaceutical industry

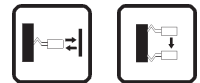

S7		
Through beam with fiber optic		0...300 mm
		0...150 mm
		0...75 mm
Diffuse proximity with fiber optic		0...100 mm
		0...50 mm
		0...25 mm
Power supply	Vdc	12...24 V
	Vac	
	Vac/dc	
Output	PNP	▪
	NPN	▪
	NPN/PNP	
	relay	
	other	
Connection	cable	▪
	connector	▪
	pig-tail	
Approximate dimensions (mm)		10x65x40
Housing material		ABS
Mechanical protection		IP65, IP60 (trimmer vers.)

TECHNICAL DATA

Power supply	12 ... 24 Vdc ± 10% (reverse polarity protection)
Ripple	2 Vpp max.
Consumption (output current excluded)	50 mA max. (mod. S7-1/2/4/5) 40 mA (mod. S7-3/6) 30 mA max. (mod. S7-7/8)
Light emission	red 670 nm (mod. S7-2/3/5/6/7/8) white 400-700 nm (mod. S7-1/4)
Setting	SET pushbutton, + pushbutton, - pushbutton (mod. S7-1/2/4/5) 1 SET pushbutton (mod. S7-3/6) 12 multiturn trimmer (mod. S7-7/8)
Indicators	yellow OUTPUT LED green STABILITY LED, DELAY LED and SPEED LED (mod. S7-1/2/4/5) green/red READY/ERROR LED (mod. S7-3/6/7/8)
Output	PNP or NPN
Output current	100 mA max.
Saturation voltage	1,2 V max. (mod. S7-3/6/7/8) 2 V max. (mod. S7-1/2/4/5)
Response time	500 µs max. (at low speed for mod. S7-1/2/7/8) 100 µs max. (at fast speed for mod. S7-2/5) 50 µs max. (at fast speed for mod. S7-1/4)
Switching frequency	1 kHz (at low speed for mod. S7-1/2/7/8) 5 kHz (at fast speed for mod. S7-2/5) 10 kHz (at fast speed for mod. S7-1/4)
Connection	2 m Ø 4 mm cable (S7-1/2/3/7), M8 4-pole connector (S7-4/5/6/8)
Dielectric strength	500 Vac, 1 min between electronics and housing
Insulating resistance	>20 MΩ, 500 Vdc between electronics and housing
Electrical protection	class 2
Mechanical protection	IP65 IP60 (mod. S7-7/8)
Ambient light rejection	according to EN 60947-5-2
Vibrations	0,5 mm amplitude, 10 ... 55 Hz frequency, for every axis (EN60068-2-6)
Shock resistance	11 ms (30 G) 6 shock for every axis (EN60068-2-27)
Housing material	ABS
Operating temperature	-10 ... 55 °C
Storage temperature	-25 ... 70 °C
Weight	115 g max. cable vers., 30 g max. conn. vers.

DIMENSIONS

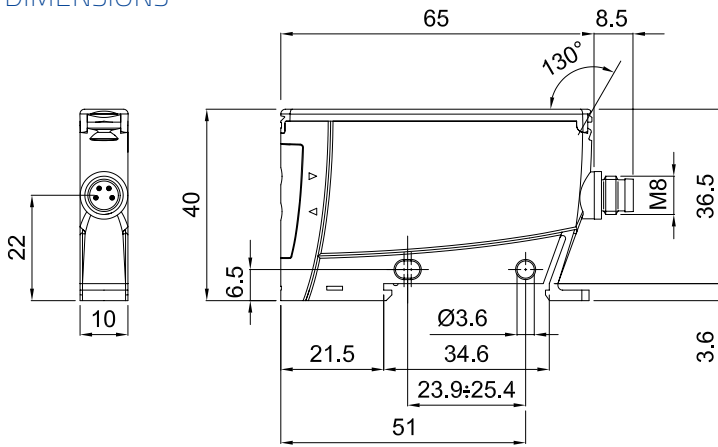

CABLE VERSION

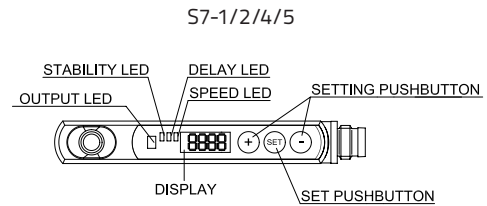
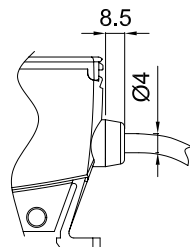
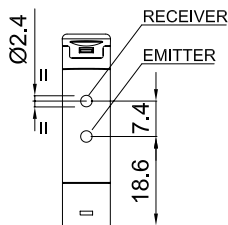

S7-3/6

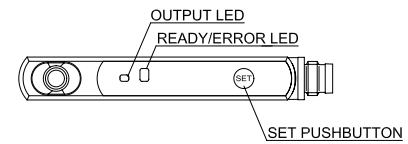

S7-7/8

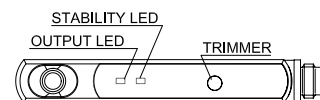

FIBER OPTIC SENSORS

CONNECTIONS

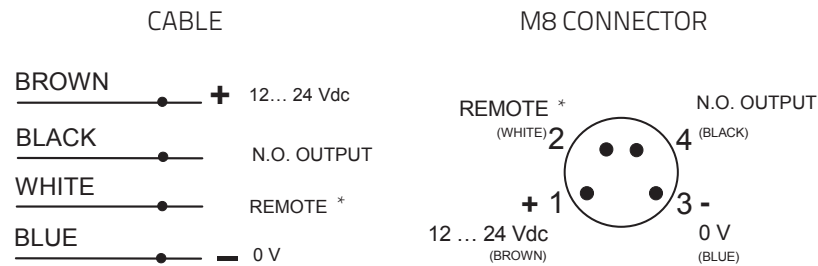

* N.C. OUTPUT on S7-7/8 models

INDICATOR AND SETTINGS

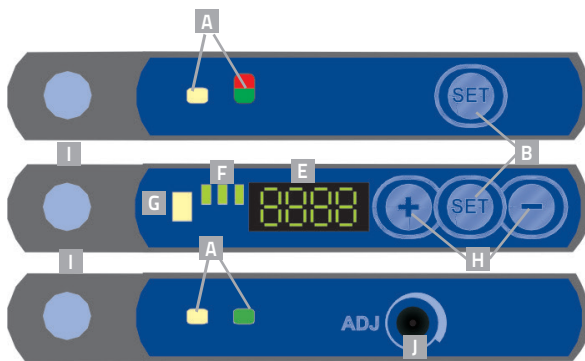

- A OUTPUT status and READY/ERROR LEDs
- B Teach-in push-button
- C M8 connector output
- D Cable output
- E 4 digit display
- F STATUS signalling LEDs
- G OUTPUT status LED
- H '+' e '-' buttons
- I Fiber lock/unlock button
- J Multiturn trimmer

Teach-in button for setting.
EASYtouch™ provides two setting modes: standard or fine.
Please refer to instructions manual for operating details

DETECTION DIAGRAMS

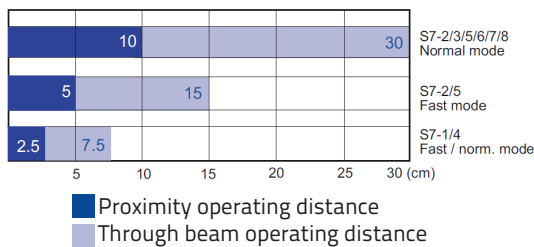

High efficiency Fiber-optics or accessory lenses can be used to obtain larger operating distances.

Note: the detection diagrams of the S7-1/4 models in normal and fast mode, corresponds to the values of the S7-2/5 models in fast mode, but with half the operating distance

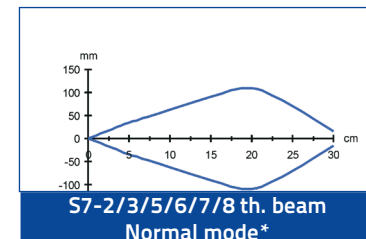
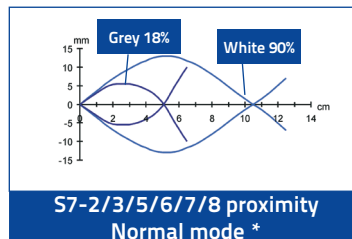
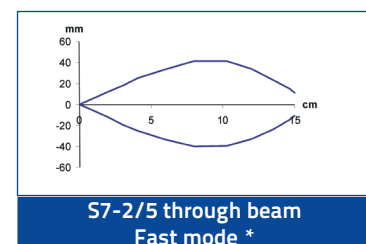
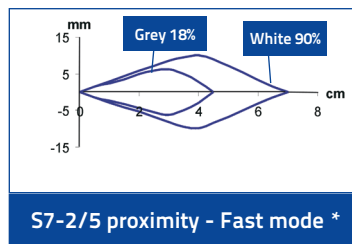

MODEL SELECTION AND ORDER INFORMATION

OPTIC FUNCTION	SETTING	CONNECTION	OUTPUT	MODEL	ORDER No.
OPTIC FIBER (white LED)	display, push-button	2m Cable	PNP	S7-1-E-P	950551090
			NPN	S7-1-E-N	950551080
		M8 Connector	PNP	S7-4-E-P	950551110
			NPN	S7-4-E-N	950551100
OPTIC FIBER (red LED)	display, push-button	2m Cable	PNP	S7-2-E-P	950551010
			NPN	S7-2-E-N	950551000
			PNP	S7-3-E-P	950551050
			NPN	S7-3-E-N	950551040
	push-buttons	M8 Connector	PNP	S7-5-E-P	950551030
			NPN	S7-5-E-N	950551020
	display, push-buttons	M8 Connector	PNP	S7-6-E-P	950551070
			NPN	S7-6-E-N	950551060
	push-buttons	M8 Connector	PNP	S7-7-E-P	950551120
			NPN	S7-7-E-N	950551130
		2m Cable	PNP	S7-8-E-P	950551140
			NPN	S7-8-E-N	950551150

Datalogic Automation offers a wide range of fiber optic cables available in two different lines: OF series for standard applications and OFA series for specialistic applications, such as 90° optics as well as fixed focus optics. These accessories allow to carry out the diffuse proximity and through beam detection of small object in difficult point of the machine. Refer to the next page for the complete list.

ACCESSORIES

ST-505

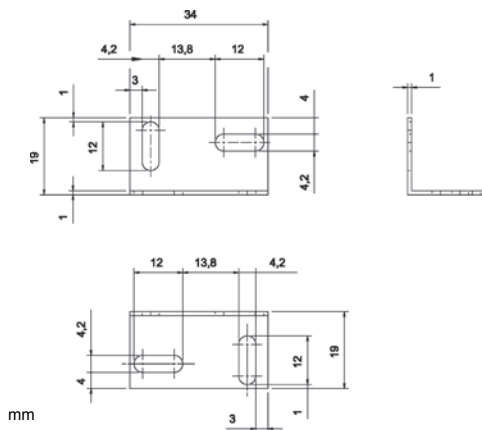

CRD-5000

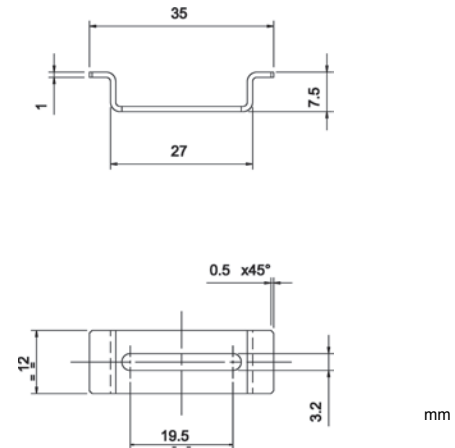

MODEL	DESCRIPTION	ORDER No.
ST -505	L-shaped mounting bracket	95ACC 2800
CRD -5000	DIN rail mounting bracket	95ACC 2790

CABLES

TYPE	DESCRIPTION	LENGTH	MODEL	ORDER No.
Axial M8 Connector	4-pole, grey, P.V.C.	3 m	CS-B1-02-G-03	95A251420
		5 m	CS-B1-02-G-05	95A251430
		7 m	CS-B1-02-G-07	95A251440
		10 m	CS-B1-02-G-10	95A251480
	4-pole, P.U.R.	2 m	CS-B1-02-R-02	95A251620
		5 m	CS-B1-02-R-05	95A251640
Radial M8 Connector	4-pole, grey, P.V.C.	3 m	CS-B2-02-G-03	95A251450
		5 m	CS-B2-02-G-05	95A251460
		7 m	CS-B2-02-G-07	95A251470
		10 m	CS-B2-02-G-10	95A251530
	4-pole, P.U.R.	2 m	CS-B2-02-R-02	95A251630
		5 m	CS-B2-02-R-05	95A251650

FIBER OPTIC SENSORS

S70

Advanced fiber optic amplifiers for high speed and low contrast applications

- DIN rail mountable models with dual digital displays
- High speed models: 200 μ s...5 ms
- Super high speed models: 10 μ s...1ms
- Teach-in setting via +/SET/- push-button/switch, remote input or IO-Link
- Standard 2 m cable or M8 4-pole connection

APPLICATIONS

- Processing and Packaging machinery
- Electronics assembling
- Pharmaceutical industry

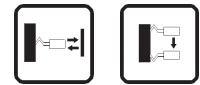

S70

Response time		Super high speed: 10 μ s (S70...E2) High speed: 200 μ s (S70...E1), 15 μ s (S70...E2) Fast: 50 μ s (S70...E2) Standard: 500 μ s (S70...E1), 250 μ s (S70...E2) Medium range: 500 μ s (S70...E2) Long range: 2 ms (S70...E1), 1 ms (S70...E2) Extra long range: 5 ms (S70...E1)
Repeatability		Super high speed: 5 μ s (S70...E2) High speed: 66 μ s (S70...E1), 5 μ s (S70...E2) Fast: 12 μ s (S70...E2) Standard: 100 μ s (S70...E1), 50 μ s (S70...E2) Medium range: 80 μ s (S70...E2) Long range: 100 μ s (S70...E1), 165 μ s (S70...E2) Extra long range: 100 μ s (S70...E1)
Power supply	Vdc	10...30 V, 18...30 V (IO-Link mod.)
	Vac	
	Vac/dc	
	Output	PNP
Output	NPN	▪
	NPN/PNP	
	relay	
	other	IO-Link
Connection	cable	▪
	connector	▪
	pig-tail	
Approximate dimensions (mm)		10x79x31.5
Housing material		ABS and polycarbonate
Mechanical protection		IP50, NEMA 1

TECHNICAL DATA

Power supply	10...30 Vdc (reverse polarity protection) 18...30 Vdc (IO-Link mod. S70...PZ)
Ripple	10% max.
Consumption (output current excluded)	40 mA max. (standard display mode), 30 mA max. (ECO display mode)
Light emission	red 660 nm (mod. S70...E1) red 635 nm (mod. S70...E2)
Setting	+ / SET / - push-button, LIGHT / DARK switch, RUN / PRG / ADJ mode switch
Indicators	yellow OUTPUT LED red SIGNAL LEVEL 4-digit display green THRESHOLD 4-digit display
Output	PNP or NPN PNP and push-pull (IO-Link mod. S70...PZ)
Output current	100 mA max.
Saturation voltage	1,5 V max. (mod. S70...N) 2 V max. (mod. S70...P/PZ)
Response time	S70...E1: 200 µs (High Speed), 500 µs (Standard), 2 ms (Long Range), 5 ms (Extra Long Range) S70...E2: 10 µs (Super High Speed), 15 µs (High Speed), 50 µs (Fast), 250 µs (Standard), 500 µs (Medium Range), 1 ms (Long Range)
Switching frequency	S70...E1: 2,5 kHz (High Speed), 1 kHz (Standard), 250 Hz (Long Range), 100 Hz (Extra Long Range) S70...E2: 50 kHz (Super High Speed), 33 kHz (High Speed), 10 kHz (Fast), 2 kHz (Standard), 1 kHz (Medium Range), 500 Hz (Long Range)
IO-Link interface	baud rate: 38400 bps (COM2) process data width: 16 bits IODD files: provide all programming options of top panel interface, plus additional functionality
Connection	2 m cable, M8 4-pole connector
Dielectric strength	500 Vac, 1 min between electronics and housing
Insulating resistance	>20 MΩ, 500 Vdc between electronics and housing
Electrical protection	class 2
Mechanical protection	IP50, NEMA 1
Ambient light rejection	according to EN 60947-5-2
Vibrations	0,5 mm amplitude, 10 ... 55 Hz frequency, for every axis (EN60068-2-6)
Shock resistance	11 ms (30 G) 6 shock for every axis (EN60068-2-27)
Housing material	ABS and polycarbonate
Operating temperature	-10 ... 55 °C
Storage temperature	-25 ... 85 °C
Weight	69 g max. cable vers., 21 g max. conn. vers.

DIMENSIONS

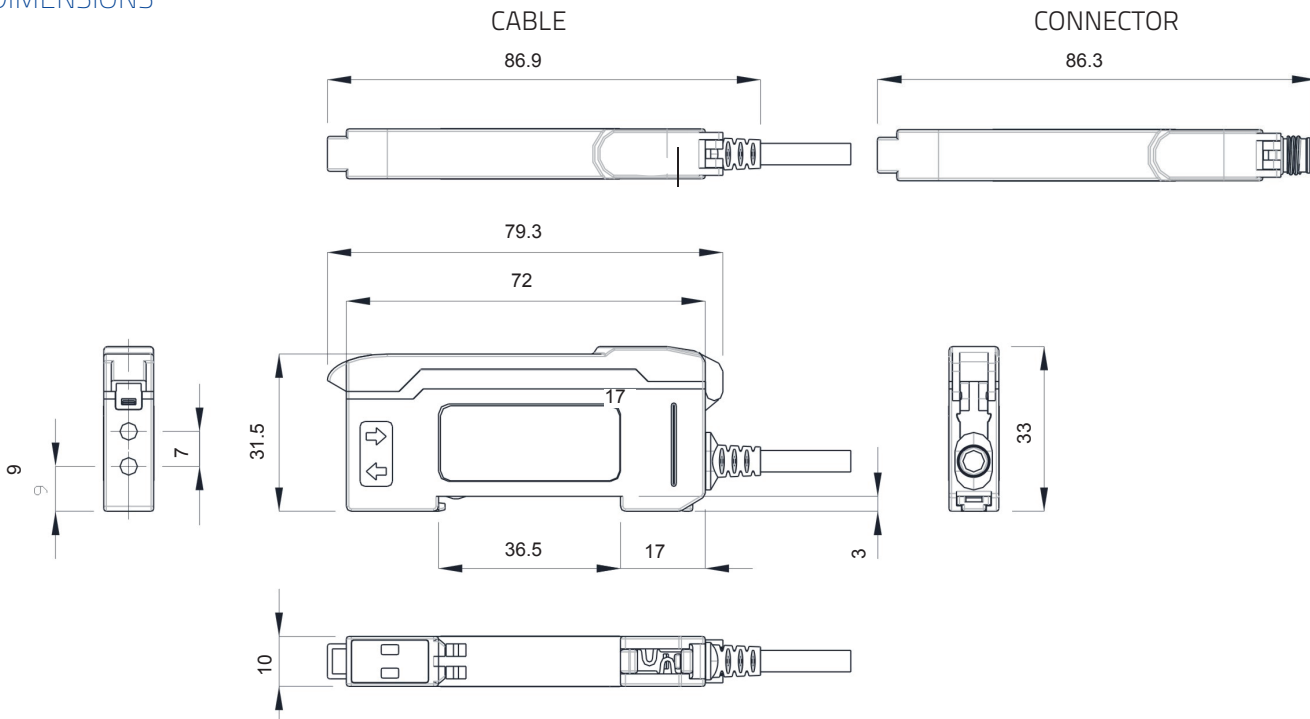

FIBER OPTIC SENSORS

CONNECTIONS

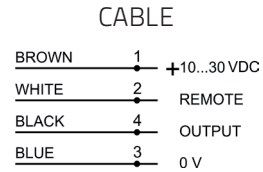
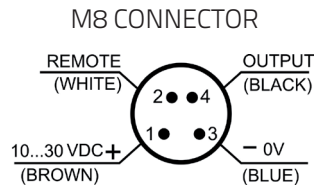

INDICATOR AND SETTINGS

The **RUN/PRG/ADJ Mode Switch** puts the sensor in RUN, PRG (Program), or ADJ (Adjust) mode. RUN mode allows the sensor to operate normally and prevents unintentional programming changes via the **+ /SET/ - button**. PRG mode allows the sensor to be programmed through the display driven programming menu. ADJ mode allows the user to perform TEACH and SET methods and Manual Adjust. The **LO/DO Switch** is used to select Light Operate or Dark Operate mode.

Top Panel Interface

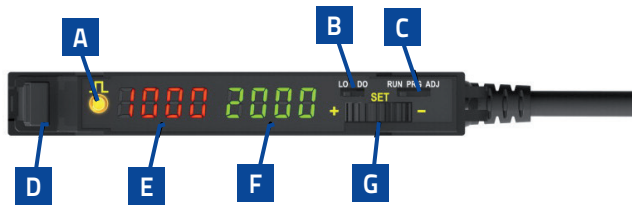

- A Output LED
- B LO/DO Switch
- C RUN/PRG/ADJ
- D Lever Action Fiber Clamp
- E Red Signal Level
- F Green Threshold
- G +/SET/- Rocker Button

As an alternative the sensor can be programmed remotely and the remote input may be used to perform TEACH and SET methods (not available on IO-Link models).

DETECTION DIAGRAMS

	S70-E1			
	HIGH SPEED	STANDARD	LONG RANGE	EXTRA LONG RANGE
Response Time	200 μ s	500 μ s	2 ms	5 ms
Repeatability	66 μ s	100 μ s	100 μ s	100 μ s

Excess gain

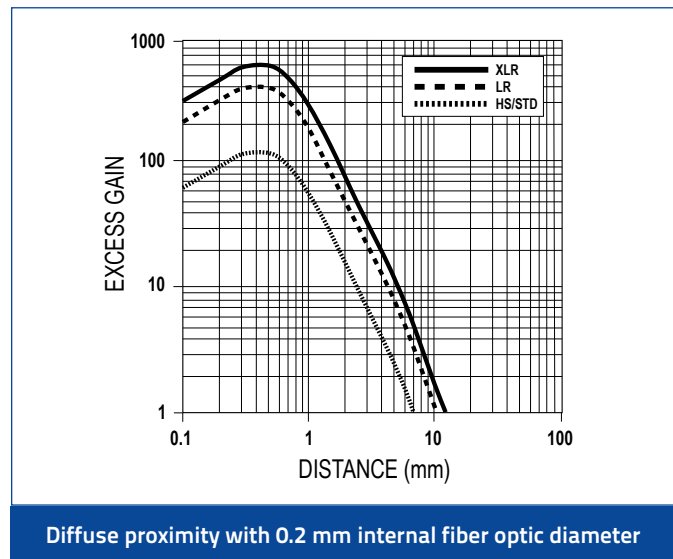
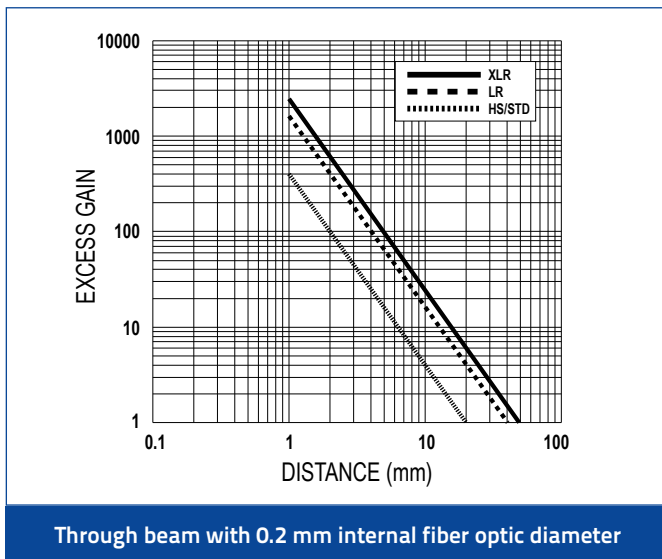

Excess gain

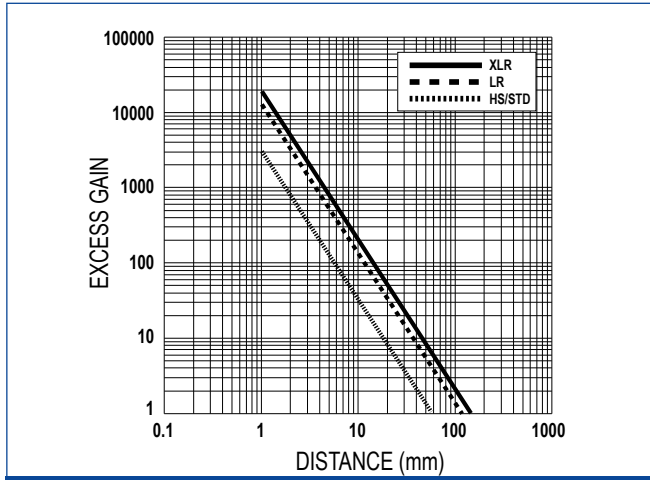

Through beam with 0.5 mm internal fiber optic diameter

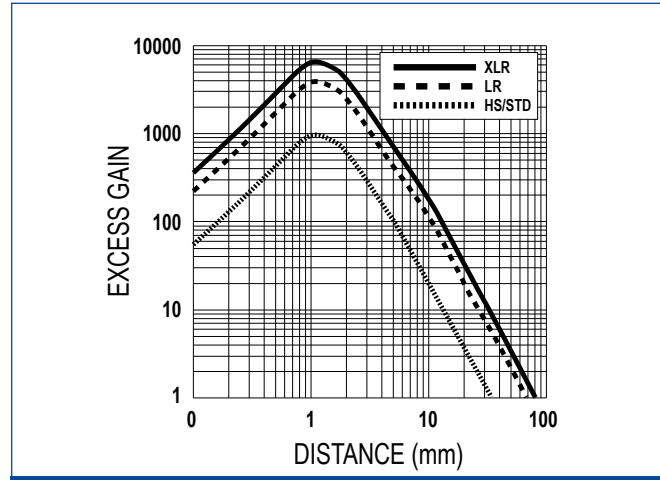

Diffuse proximity with 0.5 mm internal fiber optic diameter

Excess gain

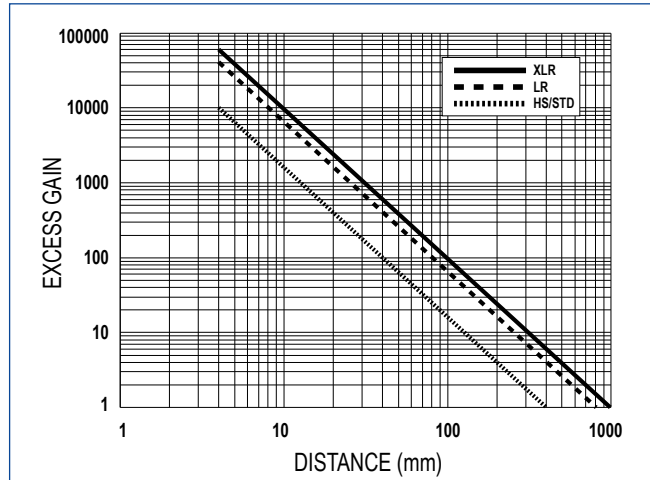

Through beam with 1 mm internal fiber optic diameter

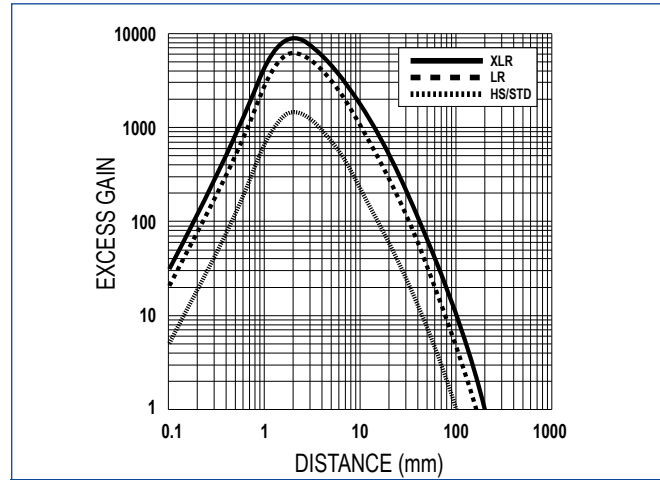

Diffuse proximity with 1 mm internal fiber optic diameter

Excess gain

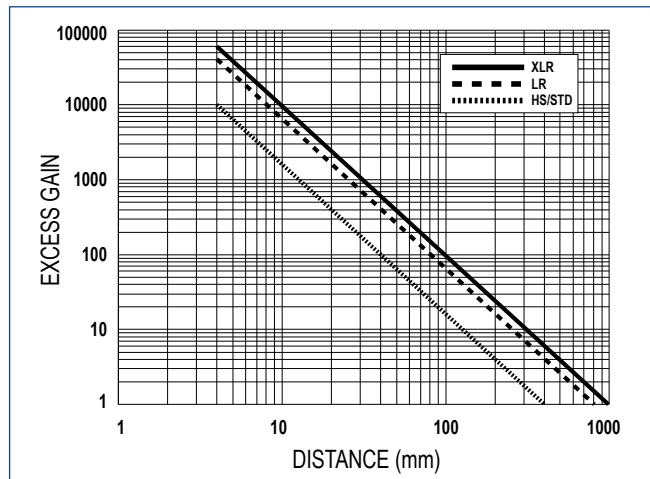

Through beam with 1.5 mm internal fiber optic diameter

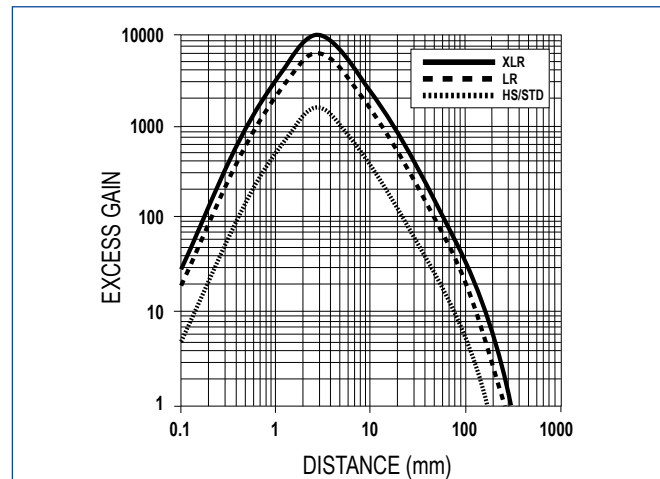

Diffuse proximity with 1.5 mm internal fiber optic diameter

FIBER OPTIC SENSORS

S70-E1

	HIGH SPEED	STANDARD	LONG RANGE	EXTRA LONG RANGE
Response Time	200 μ s	500 μ s	2 ms	5 ms
Repeatability	66 μ s	100 μ s	100 μ s	100 μ s

Detection area

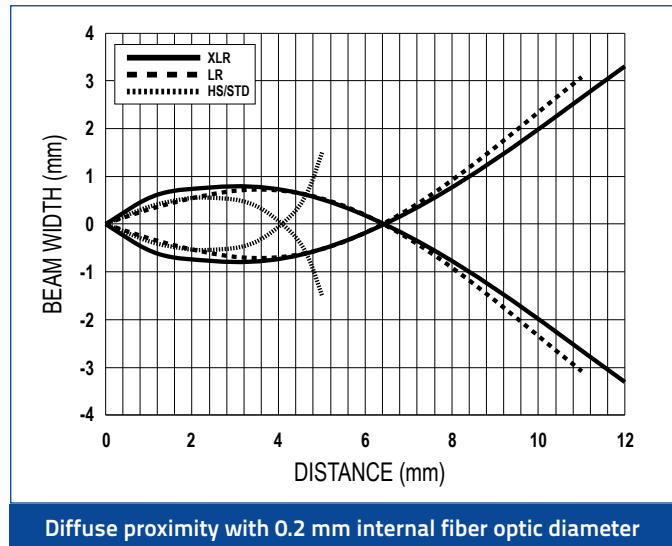
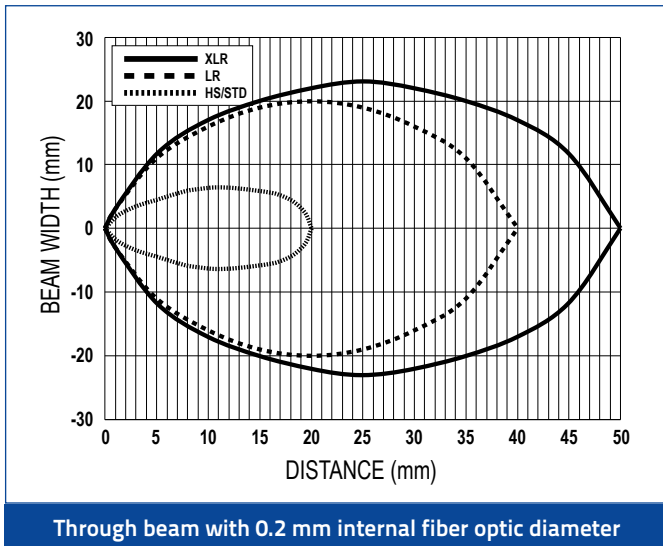

Detection area

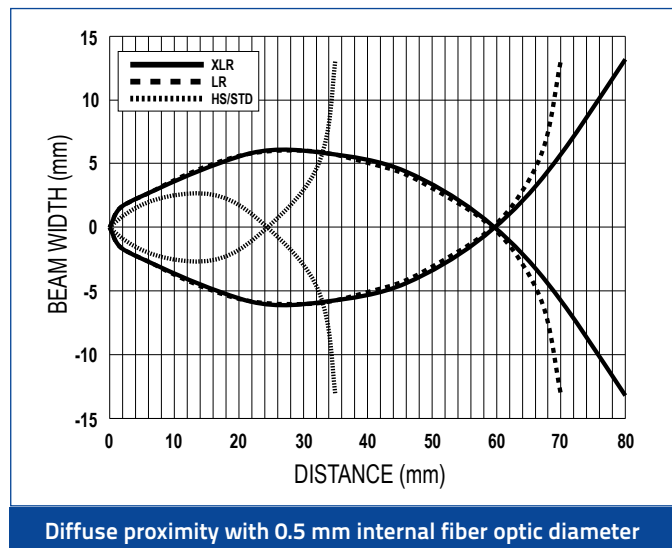
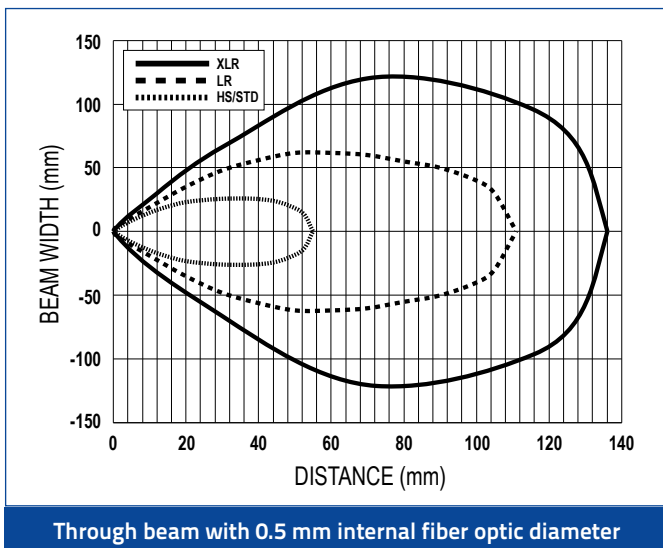

S70-E1

	HIGH SPEED	STANDARD	LONG RANGE	EXTRA LONG RANGE
Response Time	200 μ s	500 μ s	2 ms	5 ms
Repeatability	66 μ s	100 μ s	100 μ s	100 μ s

Detection area

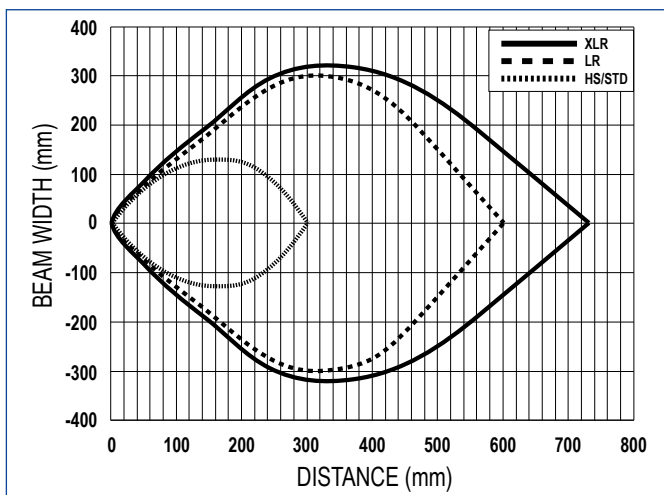

Through beam with 1 mm internal fiber optic diameter

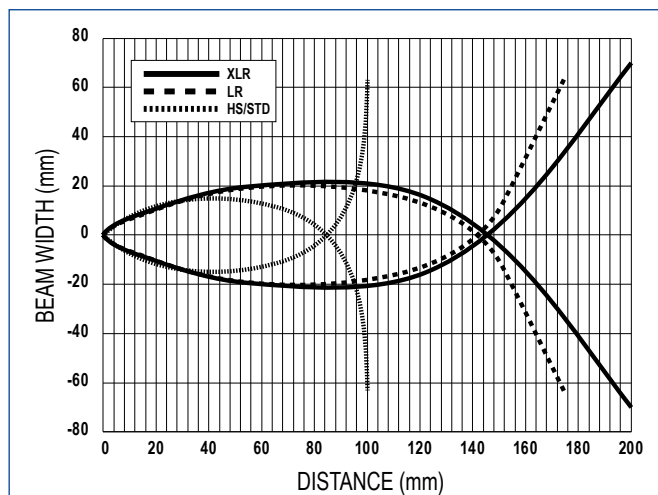

Diffuse proximity with 1 mm internal fiber optic diameter

Detection area

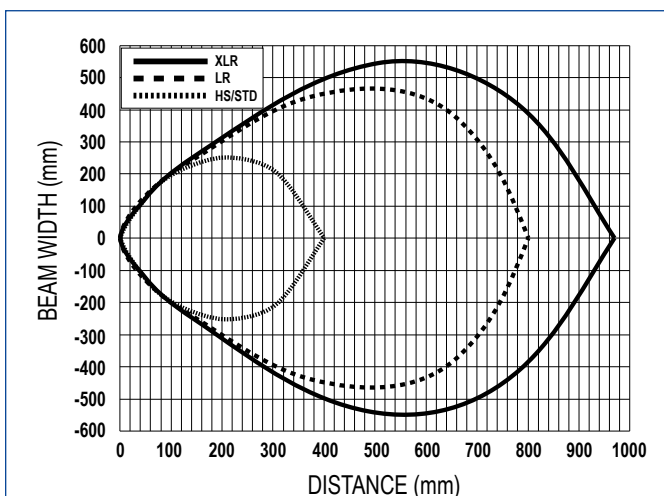

Through beam with 1.5 mm internal fiber optic diameter

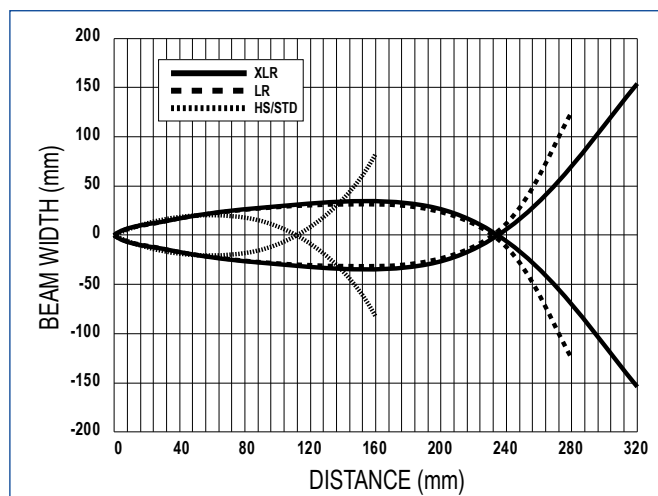

Diffuse proximity with 1.5 mm internal fiber optic diameter

FIBER OPTIC SENSORS

S70-E2

	SUPER HIGH SPEED	HIGH SPEED	FAST	STANDARD	MEDIUM RANGE	LONG RANGE
Response Time	10 μ s	15 μ s	50 μ s	250 μ s	500 μ s	1 ms
Repeatability	5 μ s	5 μ s	12 μ s	50 μ s	80 μ s	165 μ s

Excess gain

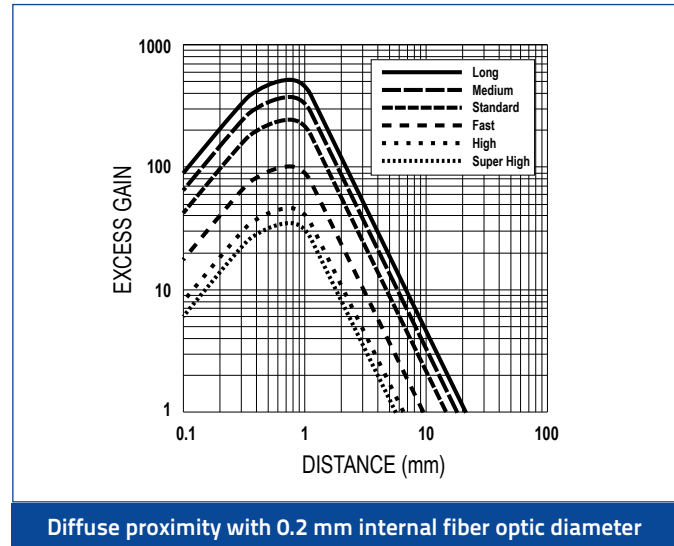
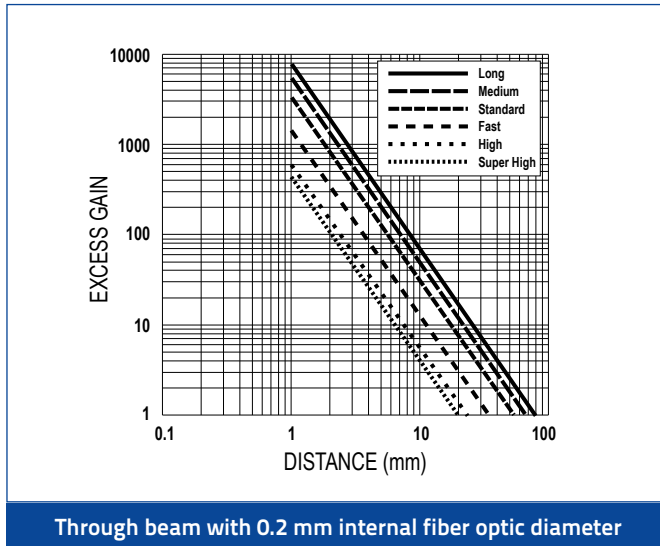

Excess gain

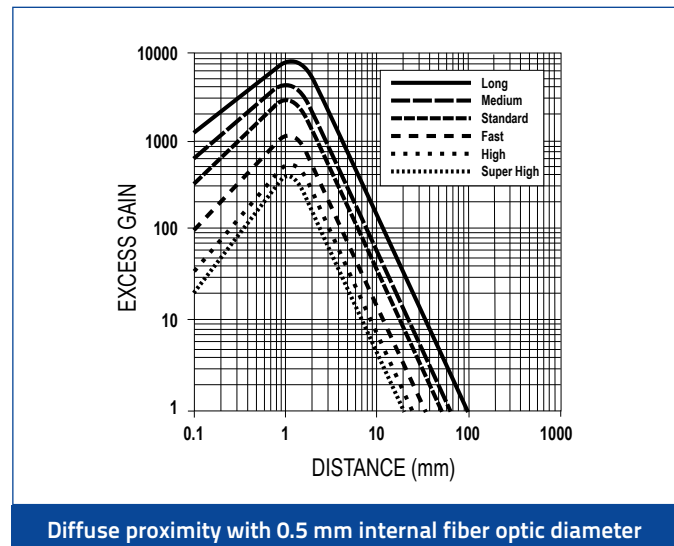
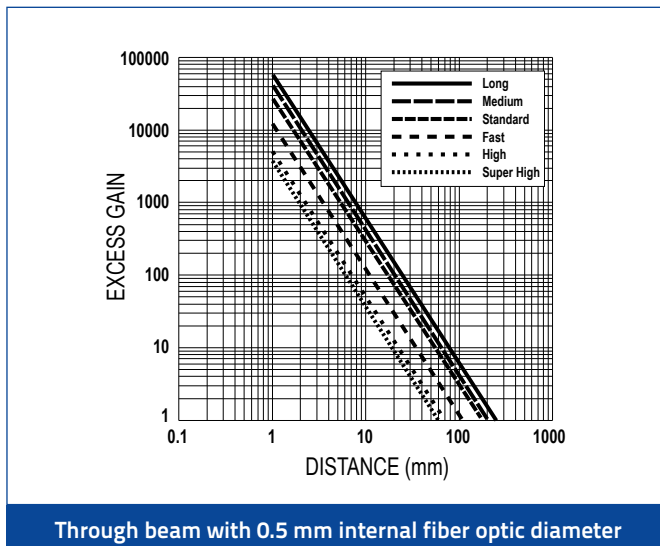

S70-E2

	SUPER HIGH SPEED	HIGH SPEED	FAST	STANDARD	MEDIUM RANGE	LONG RANGE
Response Time	10 μ s	15 μ s	50 μ s	250 μ s	500 μ s	1 ms
Repeatability	5 μ s	5 μ s	12 μ s	50 μ s	80 μ s	165 μ s

Excess gain

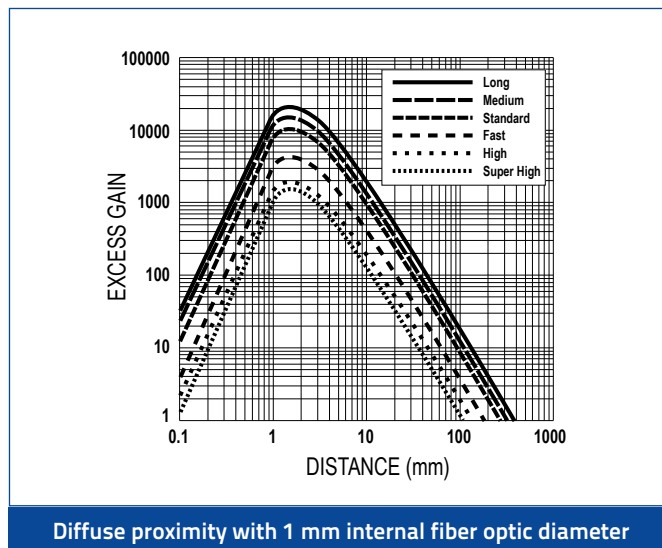
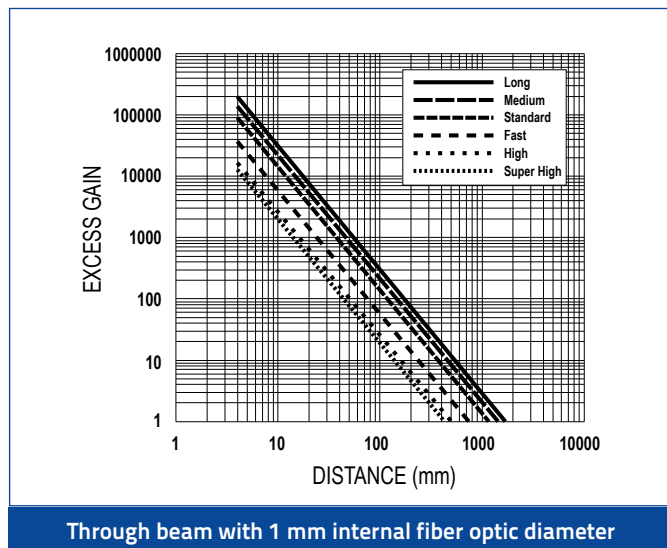

Excess gain

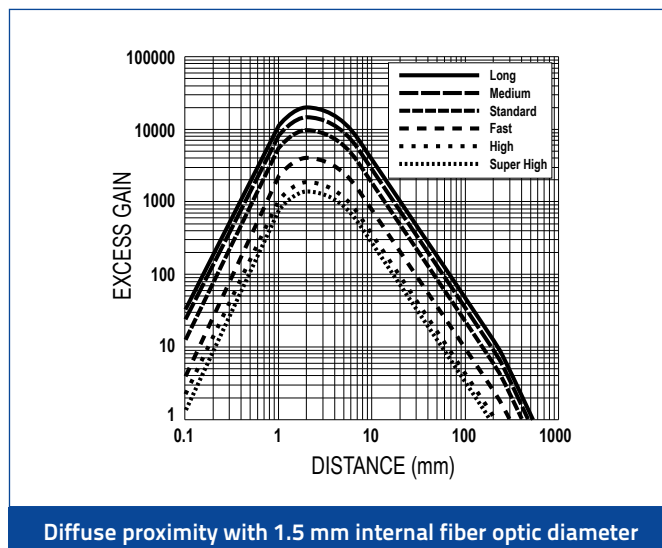
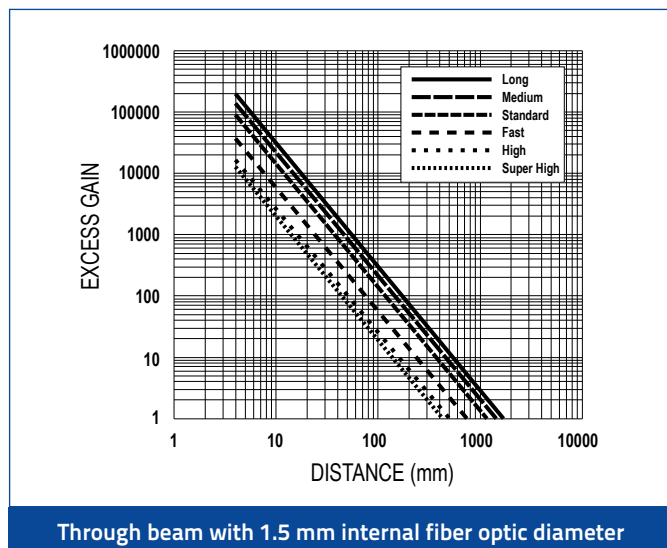

FIBER OPTIC SENSORS

S70-E2

	SUPER HIGH SPEED	HIGH SPEED	FAST	STANDARD	MEDIUM RANGE	LONG RANGE
Response Time	10 μ s	15 μ s	50 μ s	250 μ s	500 μ s	1 ms
Repeatability	5 μ s	5 μ s	12 μ s	50 μ s	80 μ s	165 μ s

Detection area

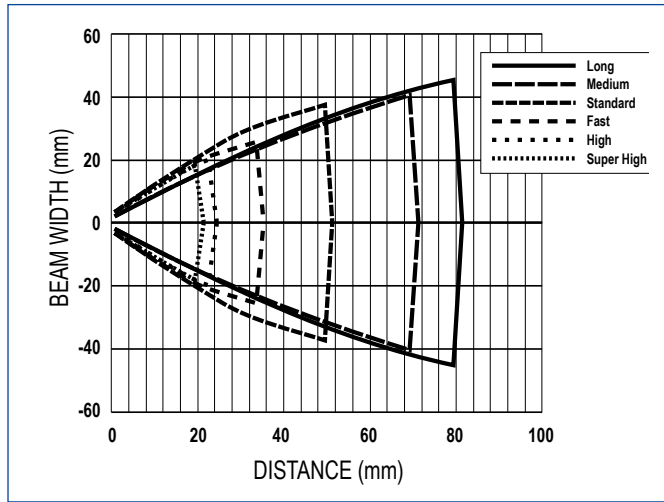

Through beam with 0.2 mm internal fiber optic diameter

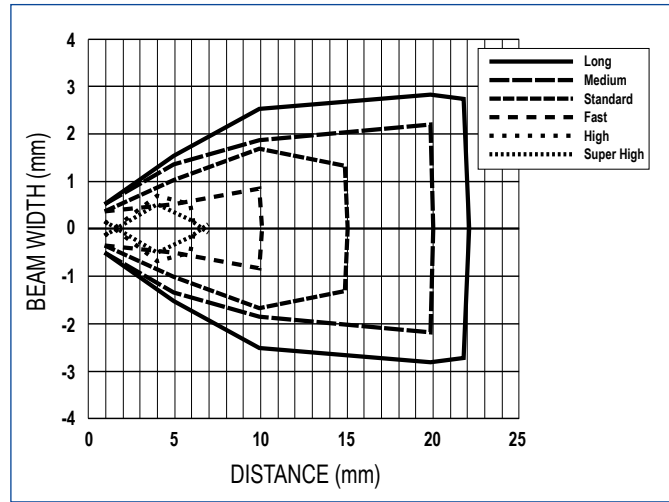

Diffuse proximity with 0.2 mm internal fiber optic diameter

Detection area

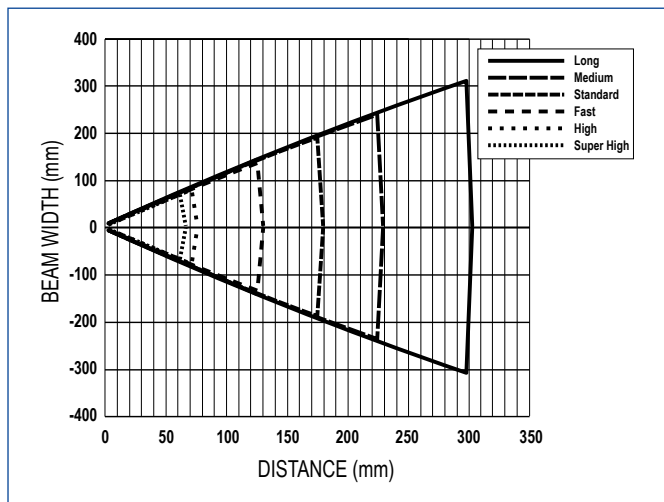

Through beam with 0.5 mm internal fiber optic diameter

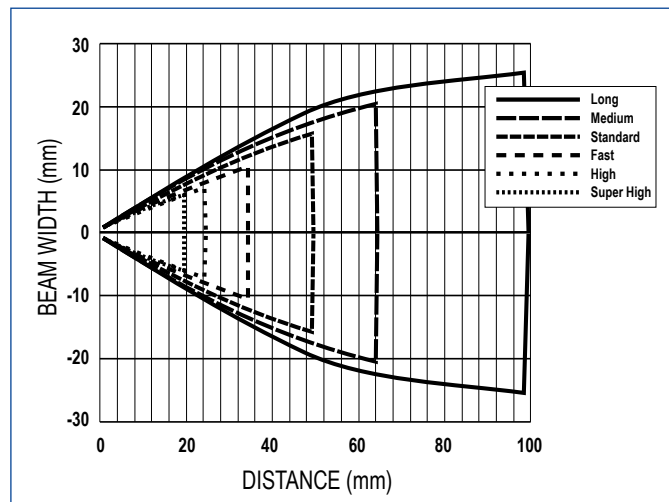

Diffuse proximity with 0.5 mm internal fiber optic diameter

S70-E2

	SUPER HIGH SPEED	HIGH SPEED	FAST	STANDARD	MEDIUM RANGE	LONG RANGE
Response Time	10 μ s	15 μ s	50 μ s	250 μ s	500 μ s	1 ms
Repeatability	5 μ s	5 μ s	12 μ s	50 μ s	80 μ s	165 μ s

Detection area

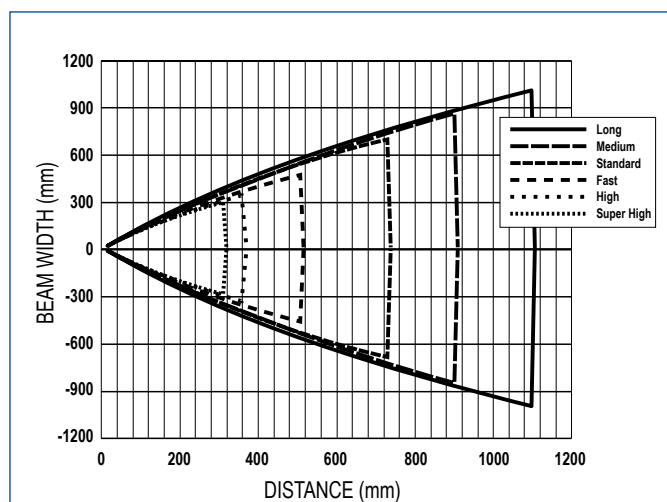

Through beam with 1 mm internal fiber optic diameter

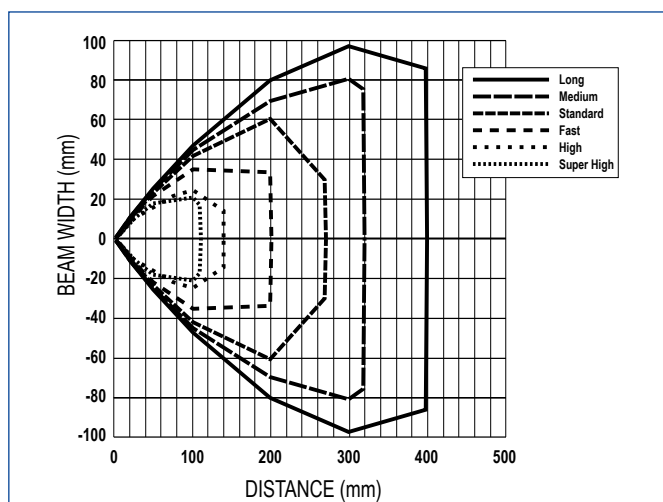

Diffuse proximity with 1 mm internal fiber optic diameter

Detection area

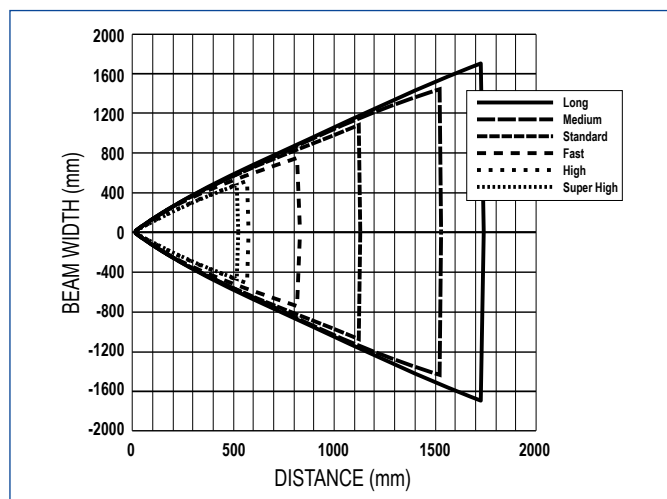

Through beam with 1.5 mm internal fiber optic diameter

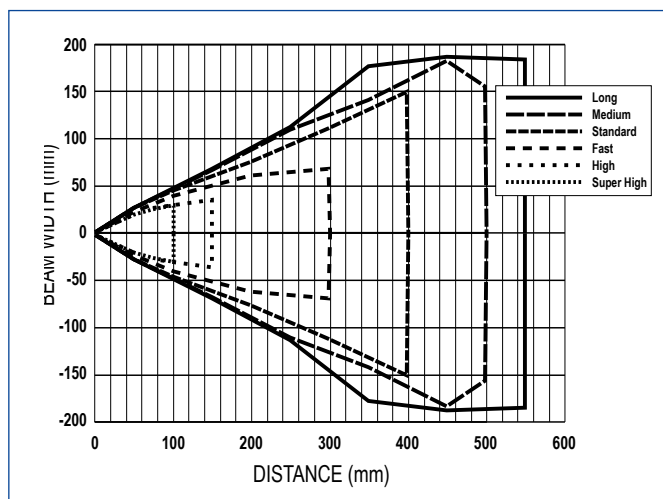

Diffuse proximity with 1.5 mm internal fiber optic diameter

FIBER OPTIC SENSORS

MODEL SELECTION AND ORDER INFORMATION

OPTIC FUNCTION	RESPONSE TIME	CONNECTION	OUTPUT	MODEL	ORDER No.
Optic fiber	200 μ s ... 5 ms	2 m Cable	NPN	S70-2-E1-N	950561000
			PNP	S70-2-E1-P	950561010
		M8 Connector	NPN	S70-5-E1-N	950561060
			PNP	S70-5-E1-P	950561020
	PNP, push-pull IO-Link		S70-5-E1-PZ	950561030	
	10 μ s ... 1 ms	M8 Connector	NPN	S70-5-E2-N	950561040
			PNP	S70-5-E2-P	950561050

ACCESSORIES

CRD-5000

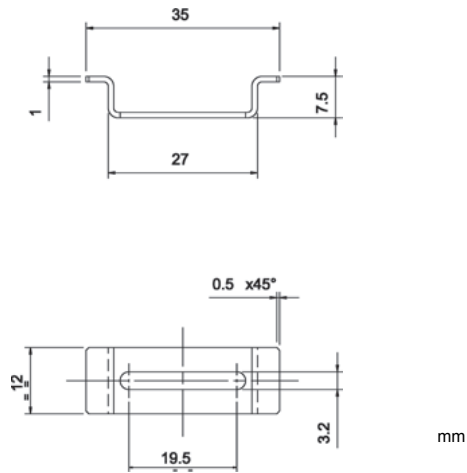

MODEL	DESCRIPTION	ORDER No.
CRD-5000	DIN rail mounting bracket	95ACC2790

CABLES

TYPE	DESCRIPTION	LENGTH	MODEL	ORDER No.
Axial M8 Connector	4-pole, grey, P.V.C.	3 m	CS-B1-02-G-03	95A251420
		5 m	CS-B1-02-G-05	95A251430
		7 m	CS-B1-02-G-07	95A251440
		10 m	CS-B1-02-G-10	95A251480
	4-pole, P.U.R.	2 m	CS-B1-02-R-02	95A251620
		5 m	CS-B1-02-R-05	95A251640
Radial M8 Connector	4-pole, grey, P.V.C.	3 m	CS-B2-02-G-03	95A251450
		5 m	CS-B2-02-G-05	95A251460
		7 m	CS-B2-02-G-07	95A251470
		10 m	CS-B2-02-G-10	95A251530
	4-pole, P.U.R.	2 m	CS-B2-02-R-02	95A251630
		5 m	CS-B2-02-R-05	95A251650



FIBER OPTIC SENSORS

OF/OFA series

Complete range of optic fibers: universal or advanced models

- Flexible models
- High temperature models (up to 125 °C)
- Fiber array with parallel beams for proximity or through beam detection
- Fixed focus proximity with axial, radial or lateral optics
- Proximity with 90° optics self-contained
- Focusing, collimating and deviating lenses



CE

OF/OFA

Through beam	Mechanical characteristics, length, diameter of the optic fiber, as well as the switching frequencies, light emitted and resolution of the optic fiber amplifier, affect the operating distances. Refer to the manuals to find the proper operating distance.
Diffuse proximity	
Fixed focus	
OF diameter	
OFA number of emitted beams	1, 16, 32
Cable lengths	1, 2 m
Operating temperature	-40...+60 °C (OF) -40...125 °C (OF-...-HT) -30...+70 °C (OFA)
Core material	PMMA plastic
Sheath material	PE plastic
Terminal material	Nickel-plated brass (OF), Stainless steel, Aluminium, ABS (OFA)
Mechanical protection	IP67

OF series					
OPTIC FUNCTION	FIBER TYPE	LENGTH	TERMINAL	MODEL	ORDER No.
Through beam	standard	1 m	M4x0.7 mm	OF-19-ST-10	S76021901
	standard	2 m	M4x0.7 mm *	OF-23-ST-20	S76022300
	thin (Ø 1 mm)	1 m	M2x0.4 mm	OF-25-TN-10	S76022500
	standard	2 m	M4x0.7 mm	OF-43-ST-20	95A201350
	high-temperature	2 m	M4x0.7 mm	OF-43-HT-20	95A201280
	ultra-flexible	2 m	M4x0.7 mm	OF-43-UF-20	95A201290
	high-efficiency	2 m	M4x0.7 mm	OF-43-HP-20	95A201300
Proximity	standard	1 m	M6x1 mm	OF-18-ST-10	S76021801
	standard	2 m	M6x1 mm *	OF-22-ST-20	S76022200
	standard	2 m	M4x0.7 mm	OF-24-ST-20	S76022400
	thin (Ø 1 mm)	1 m	M3x0.5 mm	OF-26-TN-10	S76022600
	thin (Ø 1 mm)	1 m	M3x0.5 mm *	OF-28-TN-10	S76022800
	standard	2 m	Ø 3x15 mm	OF-38-ST-20	95A201070
	standard	2 m	M6x0.75 mm	OF-42-ST-20	95A201340
	high-temperature	2 m	M6x0.75 mm	OF-42-HT-20	95A201250
	ultra-flexible	2 m	M6x0.75 mm	OF-42-UF-20	95A201260
high-efficiency	2 m	M6x0.75 mm	OF-42-HP-20	95A201270	
Coaxial proximity	standard	2 m	M6x1 mm	OF-36-ST-20	95A201000
	extra-flexible	2 m	M6x1 mm	OF-36-XF-20	95A201330
	standard	2 m	M4x0.7 mm	OF-44-ST-20	95A201310
	extra-flexible	2 m	M4x0.7 mm	OF-44-XF-20	95A201320

* a bendable stainless steel extension 90mm long protrudes from the threaded optic head



OFA series					
OPTIC FUNCTION	FIBER TYPE	LENGTH	TERMINAL	MODEL	ORDER No.
Through beam	axial, 16 beam array	2 m	15x15 mm	OFA-1-AE-20	95A201170
	radial, 16 beam array	2 m	15x15 mm	OFA-1-AS-20	95A201180
Proximity	axial, 32 beam array	2 m	20x20 mm	OFA-2-AE-20	95A201150
	radial, 32 beam array	2 m	20x20 mm	OFA-2-AS-20	95A201160
	radial	2 m	5x65 mm	OFA-6-RA-20	95A201140
Fixed focus proximity	axial	2 m	15x20 mm	OFA-4-FE-20	95A201200
	lateral	2 m	15x20 mm	OFA-4-FF-20	95A201210
	radial	2 m	15x20 mm	OFA-4-FS-20	95A201190



OF Accessories			
DESCRIPTION	SUITABLE FiberS	MODEL	CODE N°
2 pcs 90° deviating lenses	OF-43-XX	AF-1	95ACC2690
2 pcs long distance collimating lenses (x 4)	OF-43-XX	AF-2	95ACC2700
1 pc focusing lens with 4 mm resolution	OF-44-XX	AF-3	95ACC2710
1 pc focusing lens with 0.4 mm resolution	OF-44-XX	AF-4	95ACC2720
2 pcs adapters Ø 2.2 mm for thin Fibers	OF-XX-TN	AF-5	95ACC2730
1 pc metal sheath for m6 x 0.75 Fibers	OF-42-XX	AF-7	95ACC2750
1 pc metal sheath for m4 x 0.7 Fibers	OF-43-XX (*)	AF-9	95ACC2770
Fiber-cutting tool with Ø 2.2 mm and Ø 1.1 mm holes	ALL	AF-11	95ACC2780

* 2 sheaths have to be ordered for both the emitter-receiver sections

FIBER OPTIC SENSORS

DIMENSIONS

OF SERIES

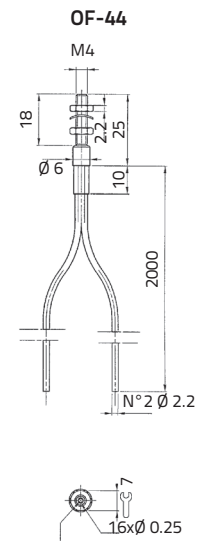
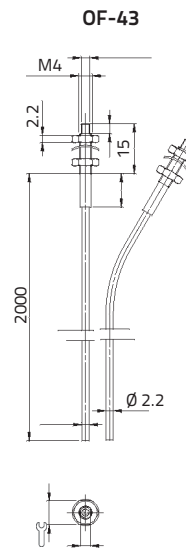
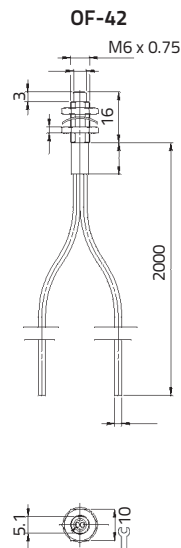
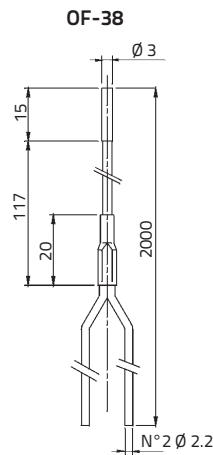
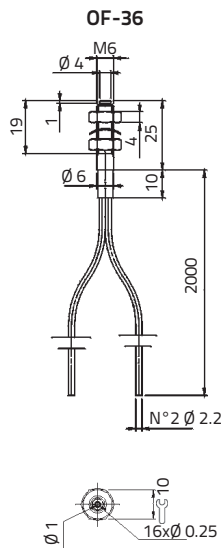
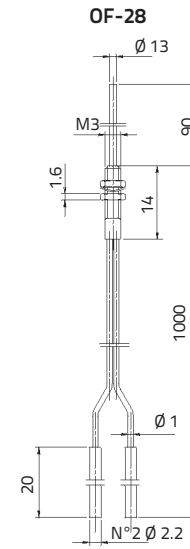
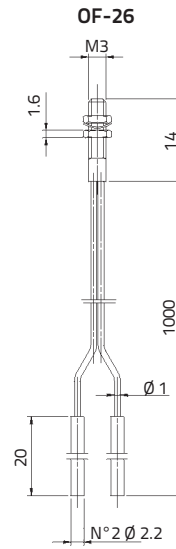
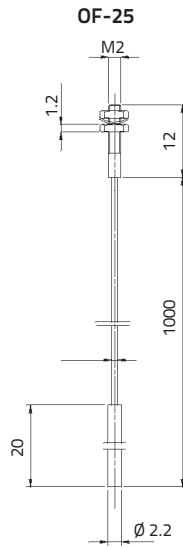
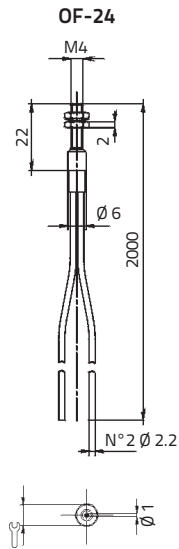
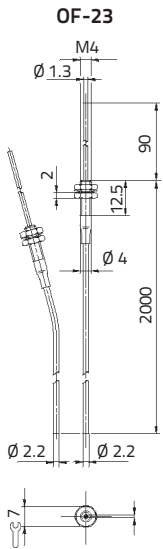
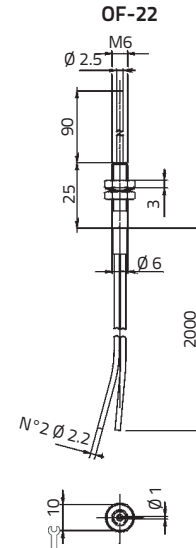
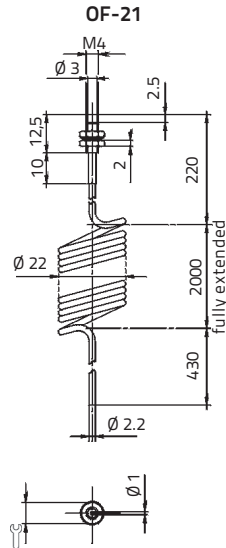
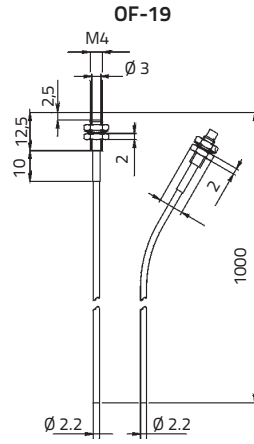
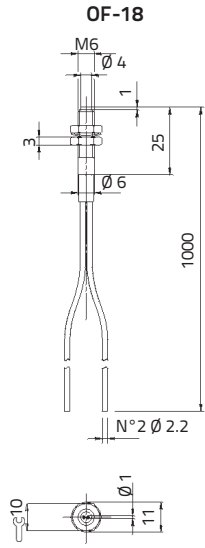

mm

DIMENSIONS

OFA SERIES

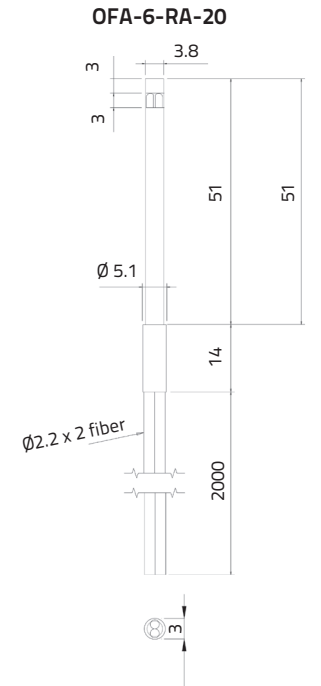
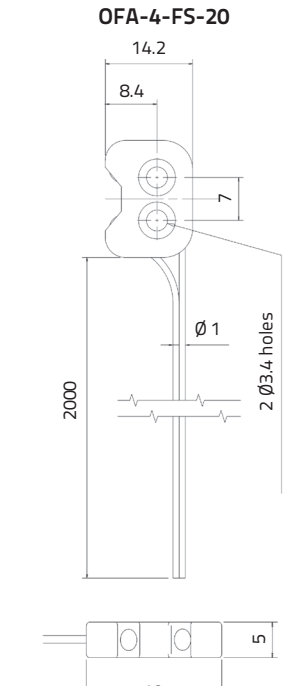
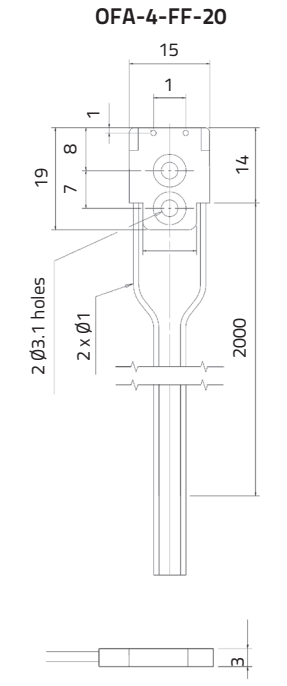
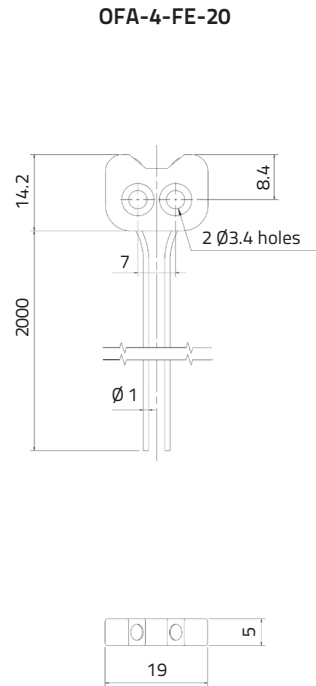
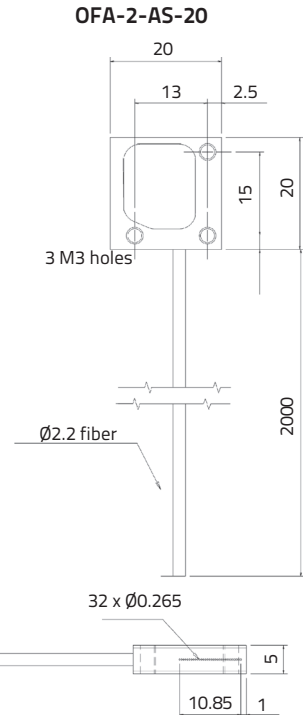
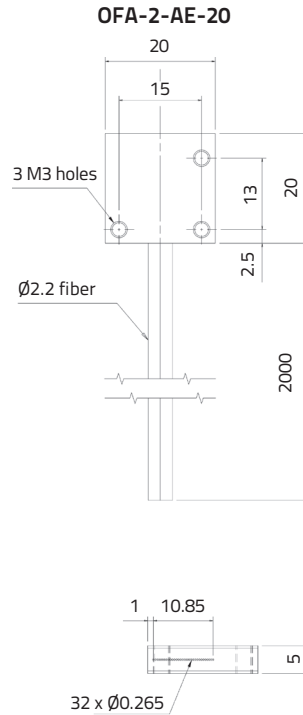
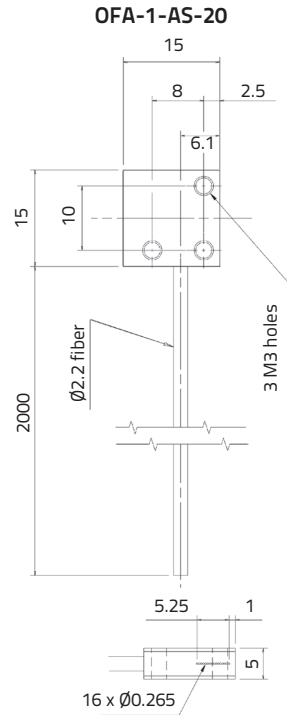
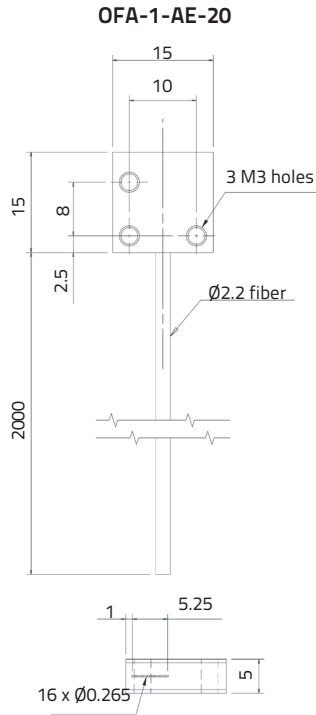

mm

FIBER OPTIC SENSORS

DETECTION DIAGRAMS

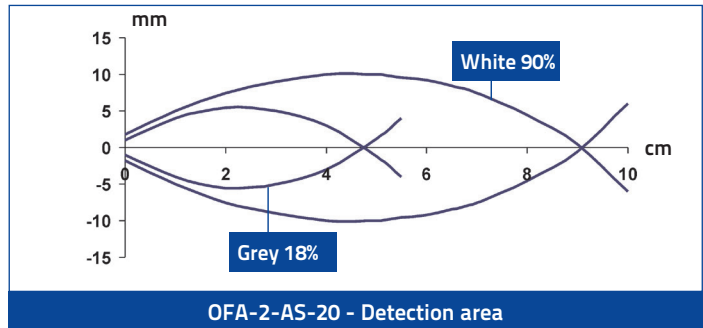
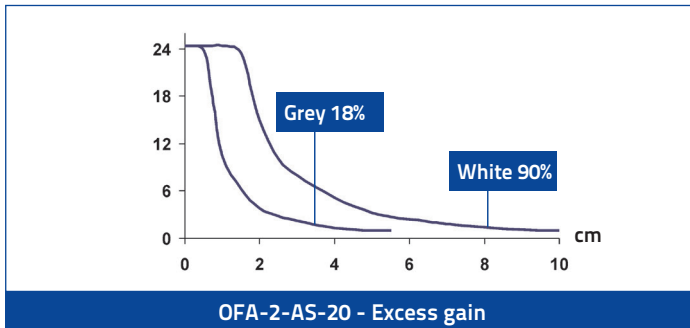
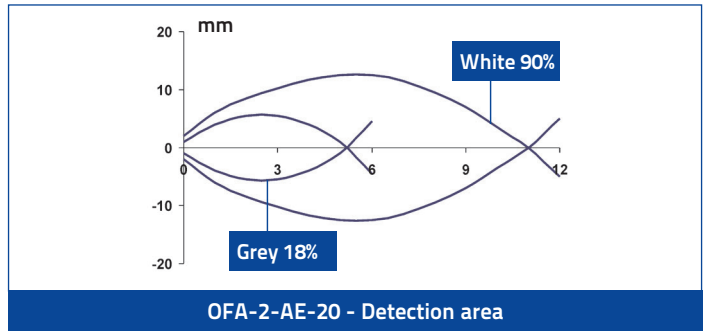
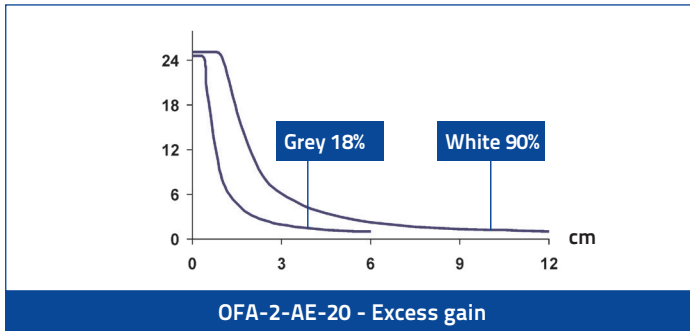
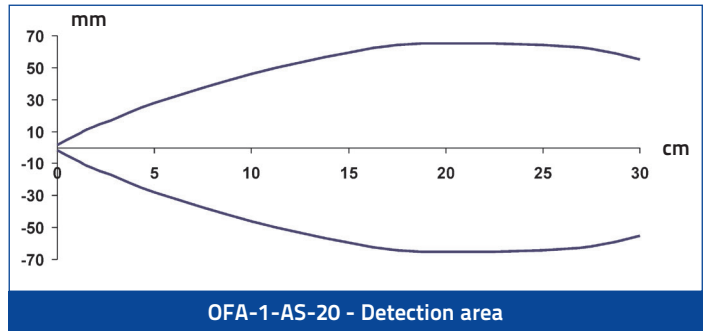
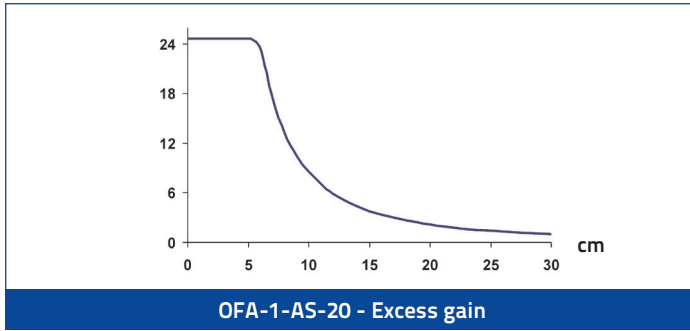

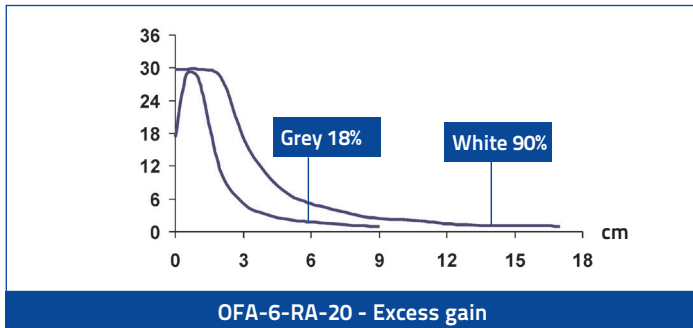
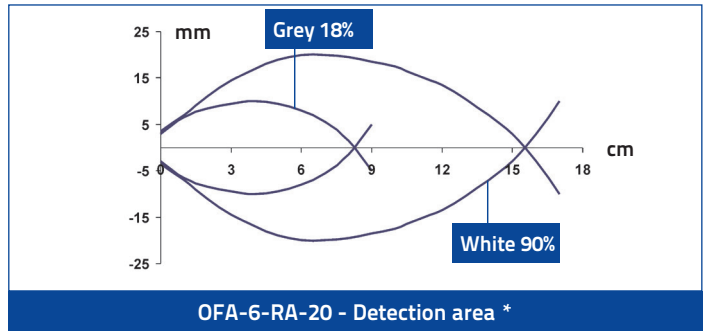
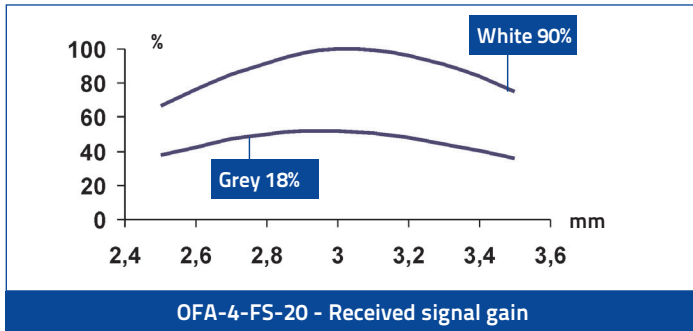
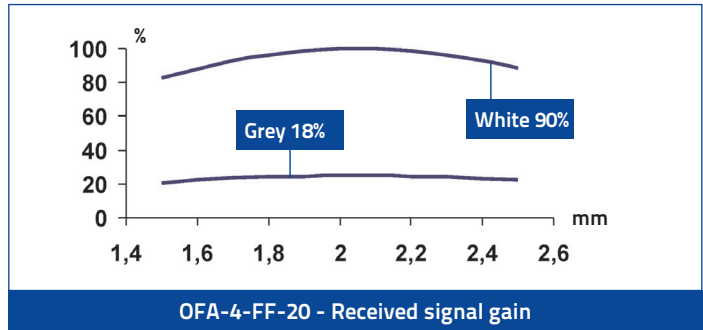
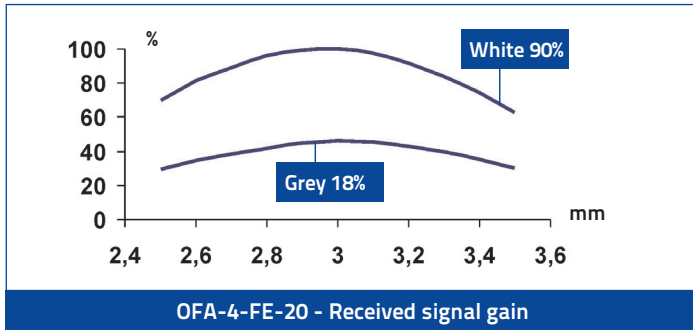

FORK SENSORS

SR21

2mm high-resolution fork sensors for labeling and packaging

- 25 kHz high switching frequency
- IR or red/green light models
- Detection of labels (SR21-IR) or print register mark on transparent films (SR21-RG)
- 4 wire NPN and PNP output



APPLICATIONS

- Packaging and labeling machinery
- Print and apply systems



SR21		
Slot width		2 mm
Slot depth		50 mm
Switching frequency		25 kHz
Light emission		IR LED red/green LED
Setting		push button
Power supply	Vdc	10...30 V
	Vac	
	Vac/dc	
Output	PNP	▪
	NPN	▪
	NPN/PNP	
	relay	
	other	
Connection	cable	
	connector	▪
	pig-tail	
Approximate dimensions (mm)		20x90x26
Housing material		Zama
Mechanical protection		IP65

TECHNICAL DATA

Power supply	10 ... 30 Vdc (limit values)
Ripple	2 Vpp max.
Consumption (output current excluded)	55 mA max.
Light emission	red LED 633 nm/green LED 570 nm IR LED 880 nm
Setting	AUTO-SET push-button
Operating mode	LIGHT/DARK configurable
Indicators	yellow OUTPUT LED green/red READY/ERROR LED
Output	PNP and NPN
Output current	100 mA max.
Saturation voltage	2 V max.
Response time	20 µs max.
Switching frequency	25 kHz max.
Connection	M8 4-pole connector
Dielectric strength	500 Vac, 1 min between electronics and housing
Insulating resistance	>20 MΩ, 500 Vdc between electronics and housing
Electrical protection	class 1
Mechanical protection	IP65
Ambient light rejection	according to EN 60947-5-2
Vibrations	0,5 mm amplitude, 10 ... 55 Hz frequency, for every axis (EN60068-2-6)
Shock resistance	11 ms (30 G) 6 shock for every axis (EN60068-2-27)
Slot width	2 mm
Resolution	0,5 mm
Housing material	ZAMA
Lens material	glass
Operating temperature	-20 ... 60 °C
Storage temperature	-20 ... 70 °C
Weight	115 g

DIMENSIONS

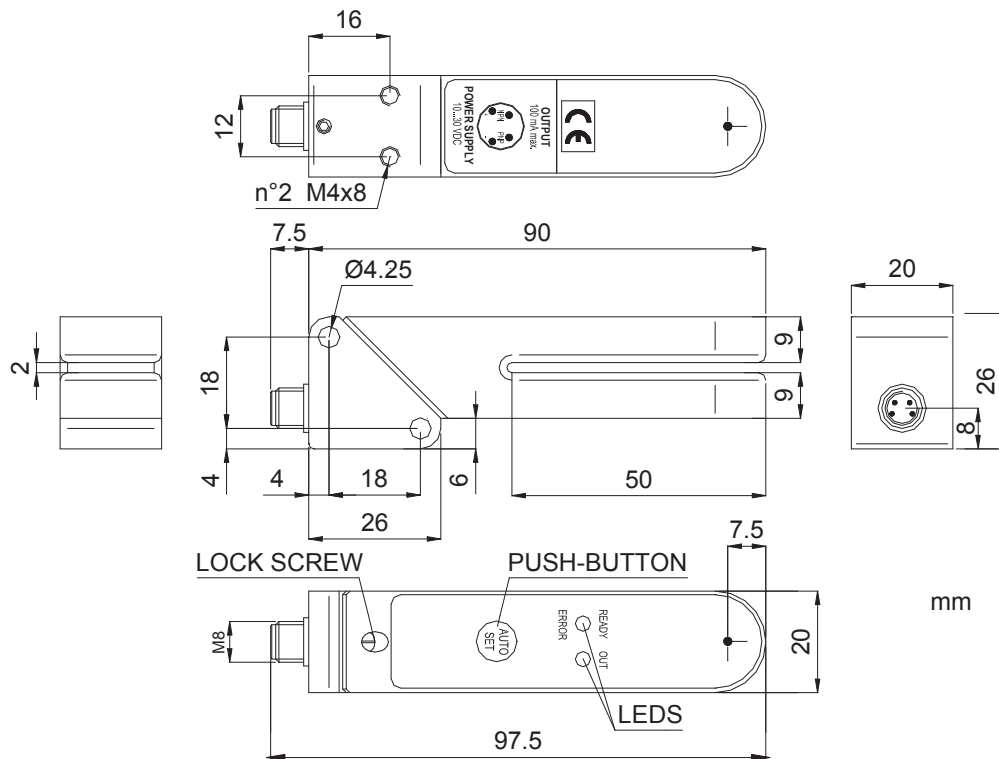

FORK SENSORS

INDICATORS AND SETTINGS

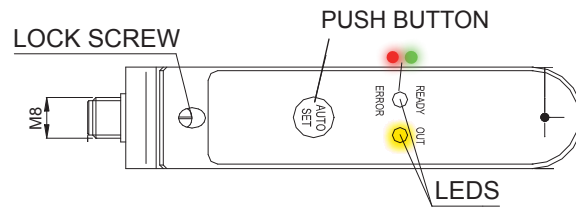
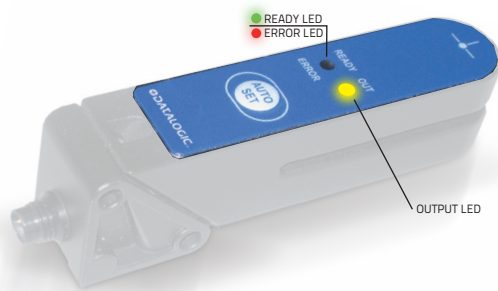

CONNECTIONS

M8 CONNECTOR

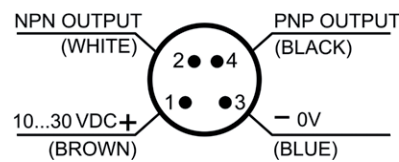

MODEL SELECTION AND ORDER INFORMATION

OPTIC FUNCTION	EMISSION	CONNECTION	OUTPUT	MODEL	ORDER No.
Fork sensor	Infrared LED	M8 Connector	PNP/NPN	SR21-IR	953151070
	Red/Green LED			SR21-RG	953151080

CABLES

TYPE	DESCRIPTION	LENGTH	MODEL	ORDER No.
Axial M8 Connector	4-pole, grey, P.V.C.	3 m	CS-B1-02-G-03	95A251420
		5 m	CS-B1-02-G-05	95A251430
		7 m	CS-B1-02-G-07	95A251440
		10 m	CS-B1-02-G-10	95A251480
	4-pole, P.U.R.	2 m	CS-B1-02-R-02	95A251620
		5 m	CS-B1-02-R-05	95A251640
Radial M8 Connector	4-pole, grey, P.V.C.	3 m	CS-B2-02-G-03	95A251450
		5 m	CS-B2-02-G-05	95A251460
		7 m	CS-B2-02-G-07	95A251470
		10 m	CS-B2-02-G-10	95A251530
	4-pole, P.U.R.	2 m	CS-B2-02-R-02	95A251630
		5 m	CS-B2-02-R-05	95A251650



FORK SENSORS

SR23

High efficiency fork sensor for booklet and multilayer labels detection

- Multilayer labels detection
- Up to 0,5 mm of minimum size labels/gap
- 5 mm slot width
- 50 mm slot depth
- Dynamic or static setting through single push-button
- 12 kHz switching frequency
- Compact and robust housing, IP65
- M8 connector or 2 m cable models
- PNP or NPN models



APPLICATIONS

- Processing and Packaging machinery
- Automatic labelers



SR23

Slot width		5 mm
Slot depth		50 mm
Switching frequency		12 kHz
Light emission		IR LED
Setting		push button
Power supply	Vdc	10...30 Vdc
	Vac	
	Vac/dc	
Output	PNP	▪
	NPN	▪
	NPN/PNP	
	relay	
Connection	other	
	cable	▪
	connector	▪
	pig-tail	
Approximate dimensions (mm)		30x63x10
Housing material		Aluminum (Zama), Plastic (PBT)
Mechanical protection		IP65

TECHNICAL DATA

Power supply	10 ... 30 Vdc (reverse polarity protection)
Ripple	2 Vpp max.
Consumption (output current excluded)	30 mA max.
Light emission	IR LED 850 nm
Setting	SET push-button yellow OUTPUT LED
Indicators	green READY LED
Output	PNP or NPN
Output current	100 mA max.
Saturation voltage	2 V max.
Slot width	5 mm
Slot depth	50 mm
Minimum label width	0,5...2 mm
Minimum space between labels	0,5...2 mm
Speed of the conveyor during setting procedure	20 m/min (30 cm/s) max.
Response time	40 µs max.
Switching frequency	12 kHz max.
Connection	M8 4-pole connector, 2 m cable
Dielectric strength	500 Vac, 1 min between electronics and housing
Insulating resistance	> 20 MΩ, 500 Vdc between electronics and housing
Mechanical protection	IP65
Ambient light rejection	according to EN 60947-5-2
Vibrations	0,5 mm amplitude, 10 ... 55 Hz frequency, for every axis (EN60068-2-6)
Shock resistance	11 ms (30 G) 6 shock for every axis (EN60068-2-27)
Housing material	Aluminum (Zama)
Cover material	PBT
Lens material	PC
Operating temperature	-20 ... 55°C
Storage temperature	-20 ... 70°C
Weight	85 g cable vers., 46 g M8 conn. vers.

DIMENSIONS

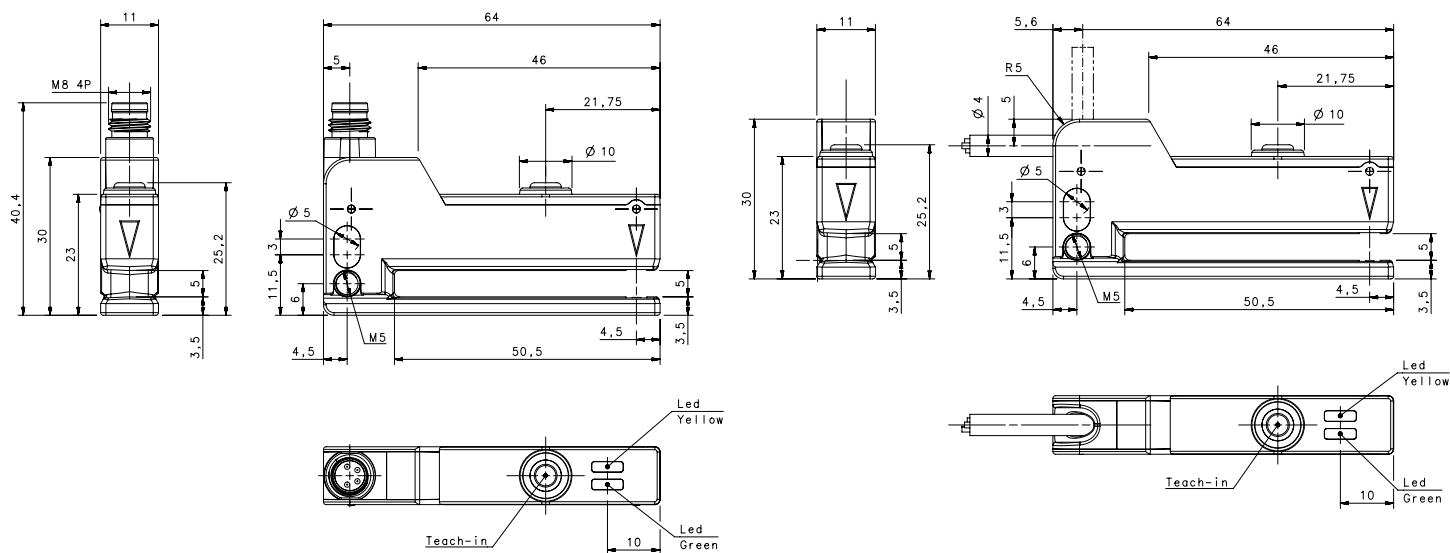

DOVETAIL GUIDE MOUNTING

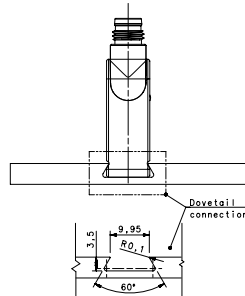

FORK SENSORS

INDICATORS AND SETTINGS

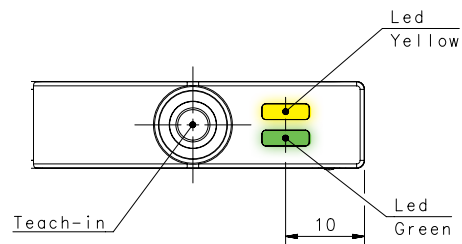

CONNECTIONS

M8 CONNECTOR

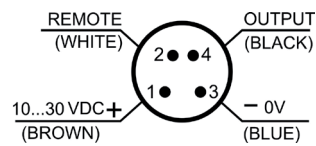

CABLE

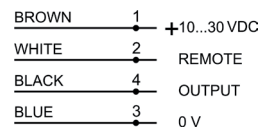

MODEL SELECTION AND ORDER INFORMATION

OPTIC FUNCTION	CONNECTION	OUTPUT	MODEL	ORDER No.
Fork Sensor	2m Cable	PNP	SR23-2-IR-PH	953161000
		NPN	SR23-2-IR-NH	953161020
	M8 Connector	PNP	SR23-5-IR-PH	953161010
		NPN	SR23-5-IR-NH	953161030

CABLES

TYPE	DESCRIPTION	LENGTH	MODEL	ORDER No.
Axial M8 Connector	4-pole, grey, P.V.C.	3 m	CS-B1-02-G-03	95A251420
		5 m	CS-B1-02-G-05	95A251430
		7 m	CS-B1-02-G-07	95A251440
		10 m	CS-B1-02-G-10	95A251480
	4-pole, P.U.R.	2 m	CS-B1-02-R-02	95A251620
		5 m	CS-B1-02-R-05	95A251640
Radial M8 Connector	4-pole, grey, P.V.C.	3 m	CS-B2-02-G-03	95A251450
		5 m	CS-B2-02-G-05	95A251460
		7 m	CS-B2-02-G-07	95A251470
		10 m	CS-B2-02-G-10	95A251530
	4-pole, P.U.R.	2 m	CS-B2-02-R-02	95A251630
		5 m	CS-B2-02-R-05	95A251650

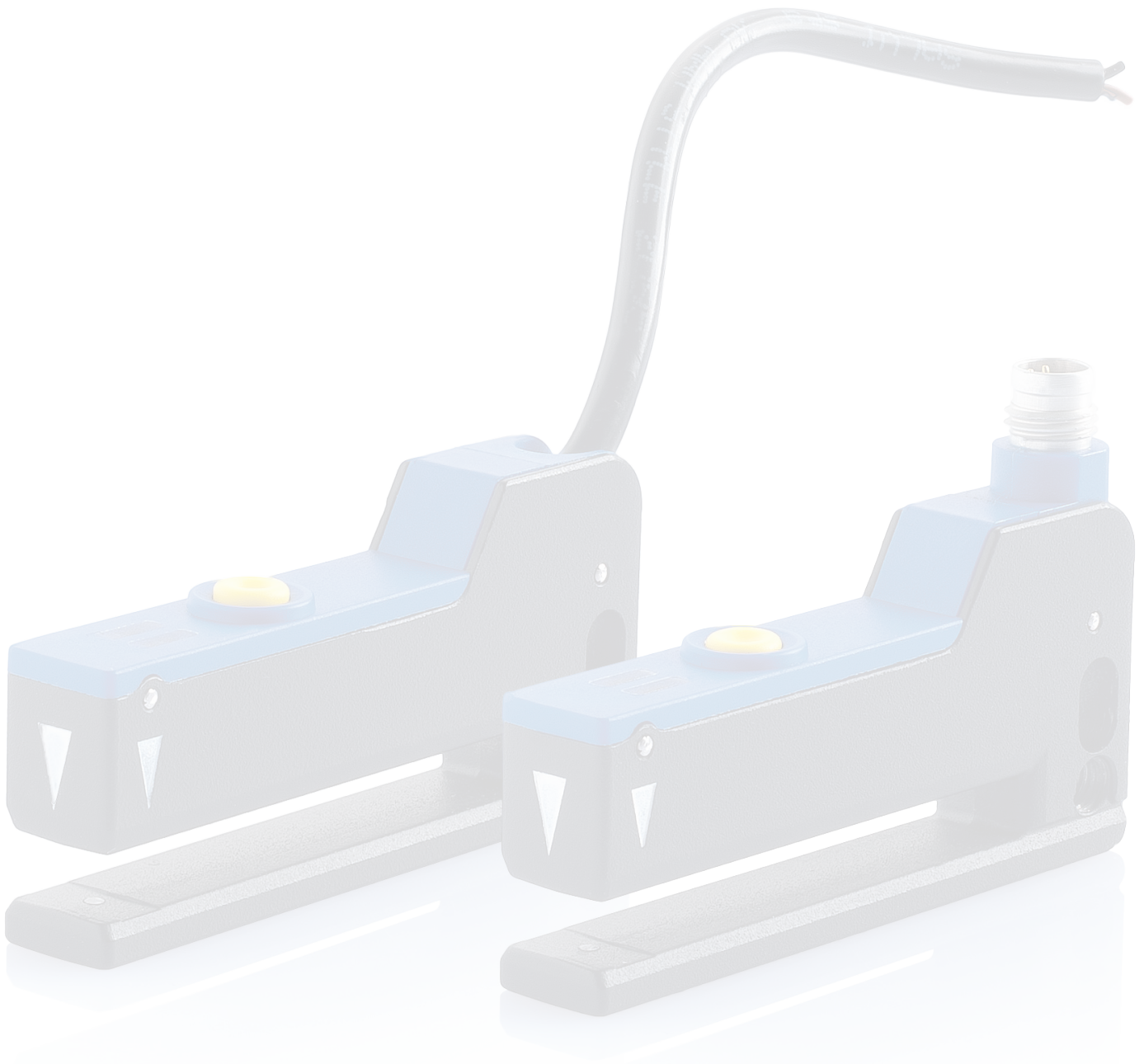

FORK SENSORS

SRF

Ultimate precision using LED or LASER emissions for high resolution

- Visible red emission models
- High resolution LASER models
- Sensitivity adjustment trimmer and DARK/LIGHT selectors
- Industrial metal housing with glass lenses



APPLICATIONS

- Packaging and labeling machinery
- Automotive
- Packaging lines



SRF-30/50/80/120		
Slot width	30 mm (SRF-30) 50 mm (SRF-50) 80 mm (SRF-80) 120 mm (SRF-120)	
Slot depth	34 mm (SRF-30) 54 mm (SRF-50/80/120)	
Switching frequency	1,5 kHz 5 kHz (class 2 LASER)	
Light emission	red LED red LASER (class 2)	
Setting	trimmer	
Power supply	Vdc	10...30 V
	Vac	
	Vac/dc	
Output	PNP	▪
	NPN	▪
	NPN/PNP	
	relay	
	other	
Connection	cable	
	connector	▪
	pig-tail	
Approximate dimensions (mm)	10x50x59 (SRF-30) 10x70x79 (SRF-50) 10x100x79 (SRF-80) 10x140x84 (SRF-120)	
Housing material	Aluminium	
Mechanical protection	IP67	

TECHNICAL DATA

Power supply	10 ... 30 Vdc (reverse polarity protection)
Ripple	2 Vpp max.
Consumption (output current excluded)	35 mA max. 20 mA max. (Laser mod.)
Light emission	red LED 640 nm red Laser 650 nm
Setting	sensitivity trimmer and N.O./N.C. trimmer
Operating mode	LIGHT/DARK configurable
Indicators	yellow LED
Output	PNP or NPN; NO; NC
Output current	200 mA max.
Saturation voltage	3 V max. PNP, 2,5 V max. NPN
Response time	333 µs 100 µs (Laser mod.)
Switching frequency	1,5 kHz 5 kHz (Laser mod.)
Connection	M8 3-pole connector
Dielectric strength	500 Vac, 1 min between electronics and housing
Insulating resistance	>20 MΩ, 500 Vdc between electronics and housing
Electrical protection	class 1
Mechanical protection	IP67
Ambient light rejection	5 kLux
Vibrations	0,5 mm amplitude, 10 ... 55 Hz frequency, for every axis (EN60068-2-6)
Shock resistance	11 ms (30 G) 6 shock for every axis (EN60068-2-27)
Slot width	30, 50, 80, 120 mm
Resolution	0,3 mm (mod. SRF...30), 0,5 mm (mod. SRF...50/80), 0,8 mm (mod. SRF...120) 0,05 mm (Laser mod. SRF...30), 0,08 mm (Laser mod. SRF...50), 0,1 mm (Laser mod. SRF...80), 0,15 mm (Laser mod. SRF...120)
Housing material	GDZn
Lens material	glass
Operating temperature	-10 ... 60 °C
Storage temperature	-20 ... 70 °C
Weight	36 g (mod. SRF...30), 54 g (mod. SRF...50), 77 g (mod. SRF...80), 118 g (mod. SRF...120) 66 g (Laser mod. SRF...30), 110 g (Laser mod. SRF...50), 135 g (Laser mod. SRF...80), 210 g (Laser mod. SRF...120)

DIMENSIONS

SRF-30

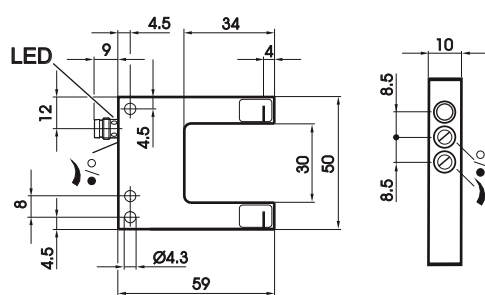

SRF-50

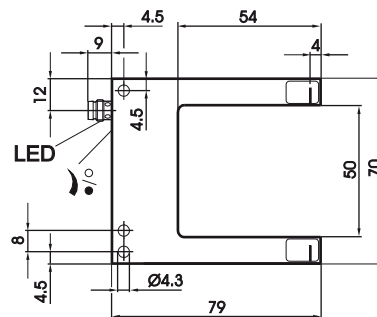

SRF-80

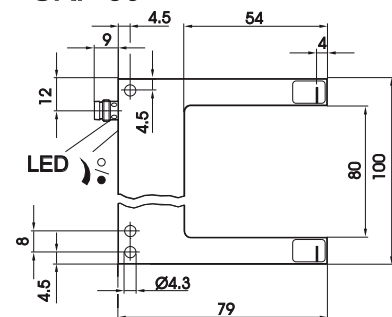

SRF-120

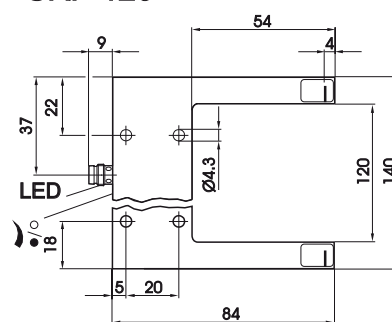

FORK SENSORS

INDICATORS AND SETTINGS

ALL MODELS

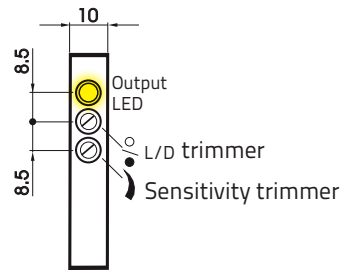

CONNECTIONS

M8 CONNECTOR

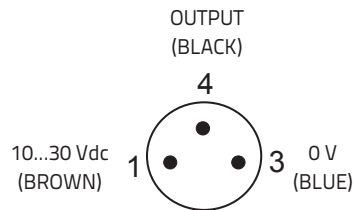

MODEL SELECTION AND ORDER INFORMATION

OPTIC FUNCTION	EMISSION	CONNECTION	OUTPUT	MODEL	ORDER No.
Fork sensor (30 mm)	Red LED	M8 Connector	PNP	SRF-30-5-P	95B020050
	LASER		NPN	SRF-30-5-N	95B020090
Fork sensor (50 mm)	Red LED	M8 Connector	PNP	SRF-L-30-5-P	95B020130
	LASER		PNP	SRF-50-5-P	95B020060
Fork sensor (80 mm)	Red LED	M8 Connector	NPN	SRF-50-5-N	95B020100
	LASER		PNP	SRF-L-50-5-P	95B020140
Fork sensor (120 mm)	Red LED	M8 Connector	PNP	SRF-80-5-P	95B020070
	LASER		NPN	SRF-80-5-N	95B020110
Fork sensor (120 mm)	Red LED	M8 Connector	PNP	SRF-L-80-5-P	95B020150
	LASER		PNP	SRF-120-5-P	95B020080
Fork sensor (120 mm)	Red LED	M8 Connector	NPN	SRF-120-5-N	95B020120
	LASER		PNP	SRF-L-120-5-P	95B020160



CABLES

TYPE	DESCRIPTION	LENGTH	MODEL	ORDER No.
Axial M8 connector	3-pole, Grey, P.V.C.	3 m	CS -B1-01-G-03	95A251490
		5 m	CS -B1-01-G-05	95A251510
Radial M8 connector		3 m	CS -B2-01-G-03	95A251500
		5 m	CS -B2-01-G-05	95A251520

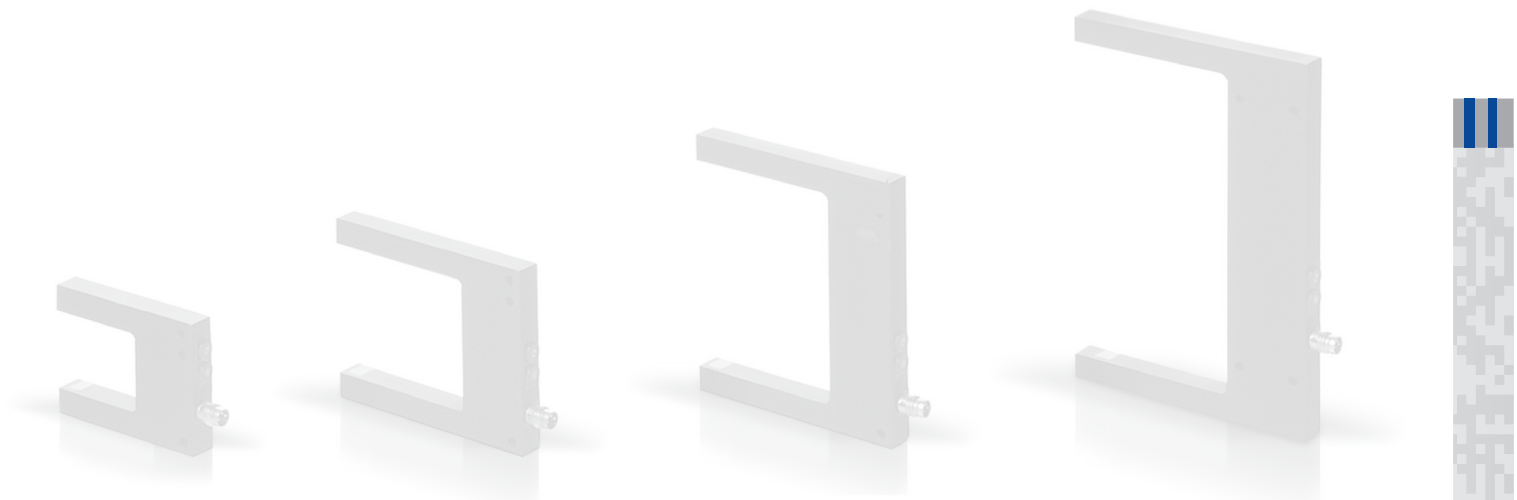

FORK SENSORS

SRX3

High performance ultrasonic fork sensors for transparent label detection

- Dynamic or static teach models
- Slot size 3mm
- High resolution up to 2 mm label gap
- M8 connector with PNP or NPN output
- M12 connector with PNP/NPN output and external teach-in
- Rugged and sturdy aluminium housing



APPLICATIONS

- Detection of transparent, opaque, or metallic ink labels
- Double sheet detection
- Adhesive surface detection



SRX3		
Slot width		3 mm
Slot depth		68 mm
Switching frequency		500 Hz
Emission type		Ultrasonic 300 KHz
Setting		300 mm
Power supply	Vdc	12...30 Vdc
	Output	
	PNP	•
	NPN	•
Connection	Connector	M12 5-pin
	Connector	M8 4-pin
Approximate dimensions (mm)		90 x 55 x 22
Housing material		Aluminium
Mechanical protection		IP54



TECHNICAL DATA	
SPECIFICATION	
Minimum pulse time	1ms
Detectable size	> 2mm
Max. tape speed	60m/min
Tape size	> 16mm
Ultrasonic frequency	300 KHz
ELECTRICAL DATA	
Power supply	12...30 Vdc
Current consumption	< 55mA
Ripple	10%
Output current	250 mA max.
Output saturation voltage	< 1,5V @ 100mA
Rising time	0,8 us max
Falling time	1,6 us max
Power On delay	325 ms
Response time	1ms
Switching frequency	500 hz
Output	PNP / NPN
MECHANICAL DATA	
Connection	M12 5 pin
Operating temperature	0 °C ...+50 °C
Storage temperature	-25 °C ...+75 °C
Humidity	35...85% rH non condensing
Vibration	0.5 mm amplitude, 10 ... 55 Hz frequency, for every axis (EN60068-2-6)
Shock resistance	11 ms (30 G) 6 shock for every axis (EN60068-2-27)
Housing material	Aluminium
Protection class	IP54
Weight	300g

DIMENSIONS

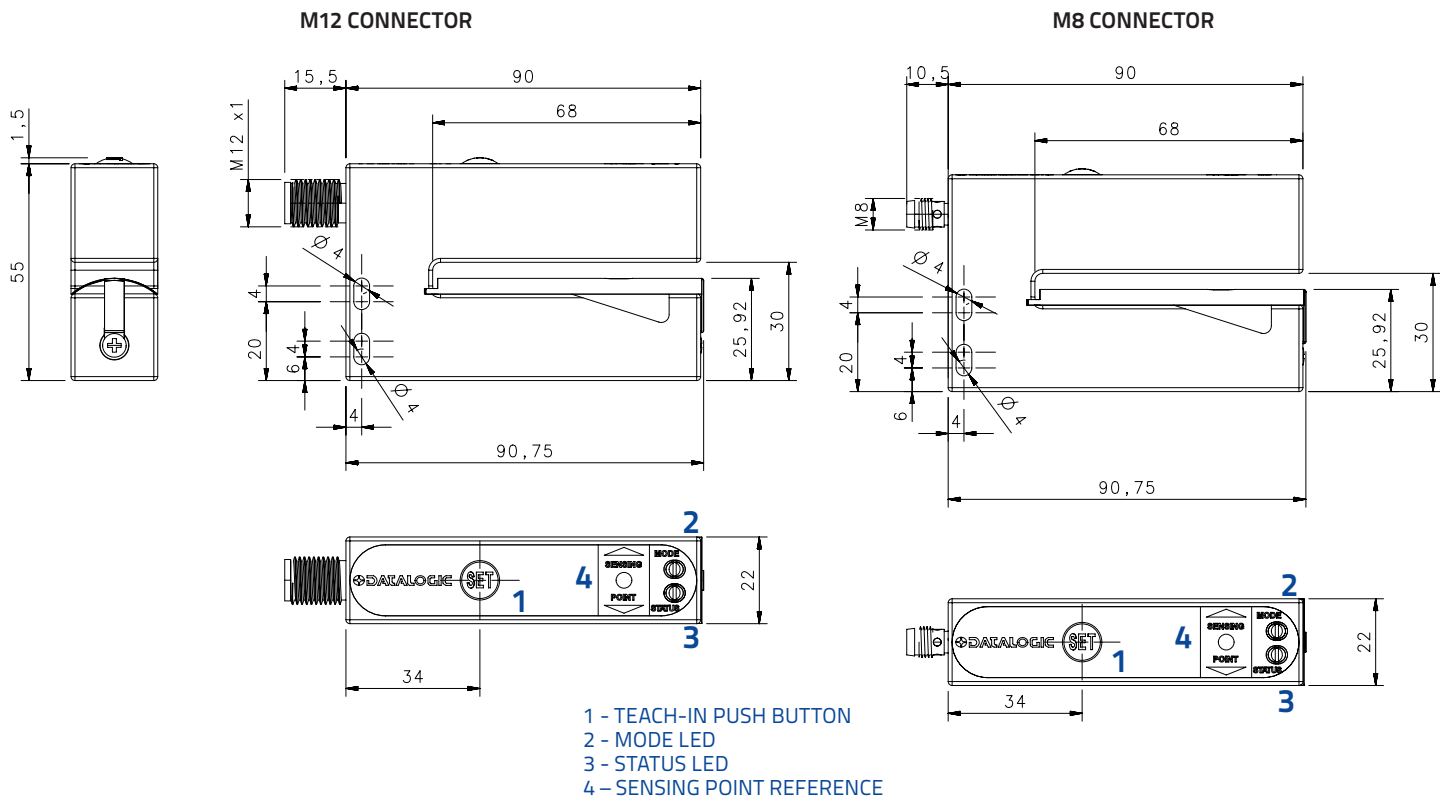

FORK SENSORS

INDICATORS AND SETTINGS



- 1 - TEACH-IN PUSH BUTTON
- 2 - MODE LED
- 3 - STATUS LED (OUTPUT LED)
- 4 - SENSING POINT REFERENCE

CONNECTIONS

M12 CONNECTOR – 5 PIN

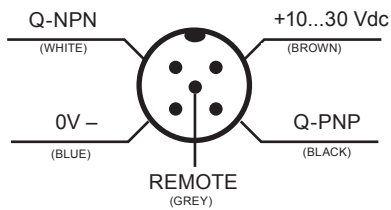

BROWN	1	+10...30 Vdc
WHITE	2	Q-NPN
BLACK	4	Q-PNP
BLUE	3	— 0 V
GREY	5	TEACH-IN

M8 CONNECTOR – 8 PIN

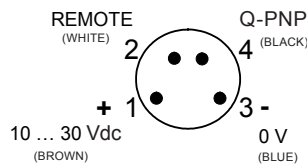

BROWN	1	+10...30 Vdc
WHITE	2	REMOTE
BLACK	4	Q-PNP
BLUE	3	— 0 V

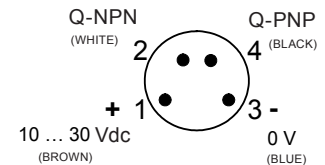

BROWN	1	+10...30 Vdc
WHITE	2	Q-NPN
BLACK	4	Q-PNP
BLUE	3	— 0 V

MODEL SELECTION AND ORDER INFORMATION

ADJUSTMENT	OUTPUT	CONNECTION	MODEL	ORDER No.
Dynamic Teach-in	PNP/NPN +EXT	M12 5 pin	SRX3-5-US-M12-PNH	953171000
Static Teach-in	PNP/NPN +EXT	M12 5 pin	SRX3-5-US-3-M12-PNH	953171010
Dynamic Teach-in	PNP+EXT	M8 4 pin	SRX3-6-US-M8-PH	953171020
Static Teach-in	PNP+EXT	M8 4 pin	SRX3-6-US-3-M8-PH	953171030
Dynamic Teach-in	PNP/NPN	M8 4 pin	SRX3-6-US-M8-PN	953171040
Static Teach-in	PNP/NPN	M8 4 pin	SRX3-6-US-3-M8-PN	953171050

CABLES

TYPE	No. Of POLES	SHEAT	LENGTH	DESCRIPTION	ORDER No.
Female M12 Connector (Axial)	5-poles	Grey, P.V.C.	3 m	CS-A1-03-G-03	95ACC2110
			5 m	CS-A1-03-G-05	95ACC2120
			10 m	CS-A1-03-G-10	95ACC2140
		Black, P.V.C. UL	3	CS-A1-03-U-03	95ASE1170
			5	CS-A1-03-U-05	95ASE1180
			10	CS-A1-03-U-10	95ASE1190
M8 Connector (Axial)	4-poles	Grey, P.V.C.	3 m	CS-B-1-02-G-03	95A251420
			5 m	CS-B-1-02-G-05	95A251430
			7 m	CS-B-1-02-G-07	95A251440
			10 m	CS-B-1-02-G-10	95A251480
		P.U.R.	2 m	CS-B-1-02-R-02	95A251500
			5 m	CS-B-1-02-R-05	95A251520
M8 Connector (radial 90°)	4-poles	Grey, P.V.C.	3 m	CS-B2-02-G-03	95A251450
			5 m	CS-B2-02-G-05	95A251480
			7 m	CS-B2-02-G-07	95A251470
		P.U.R.	5 m	CS-B2-02-R-05	95ACC2110

CONTRAST SENSORS

TL μ

All registration mark detection applications

- Teach-in, Remote settings
- Red/green or white LED emission
- Various interchangeable lenses and fiber-optic models
- Metal housing with orientable optics and connector

APPLICATIONS

- Packaging and labeling machinery
- Beverage/Food/Cosmetic/
Pharmaceutical industries
- Printing machinery

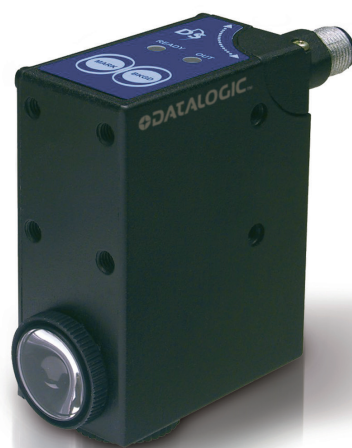

TL μ		
Contrast sensor		6...12 mm (9 mm lens) 14...22 mm (18 mm lens) 22...34 mm (28 mm lens) 40...60 mm (50 mm lens)
Contrast sensor with fiber optic		0...3 mm (proximity) 0...10 mm (through beam)
Switching frequency		10 kHz 20 kHz
Light emission		red/green LED white LED
Setting		push buttons remote
Power supply	Vdc	10...30 V
	Vac	
	Vac/dc	
Output	PNP	▪
	NPN	▪
	NPN/PNP	
	relay	
	other	0...5 V Analog Output
Connection	cable	▪
	connector	▪
	pig-tail	
Approximate dimensions (mm)		31x81x58
Housing material		Zama
Mechanical protection		IP67

TECHNICAL DATA

Power supply	10 ... 30 Vdc (limit values; reverse polarity protection)
Ripple	2 Vpp max.
Consumption (output current excluded)	80 mA max.
Light emission	green LED 526 nm / red LED 630 nm (mod. TL μ -0/1xx) white LED 400-700 nm (mod. TL μ -4/5xx)
Setting	teach-in push-buttons/remote by 2 wires, 4 settings storage cable version
Operating mode	Light/Dark automatic setting with teach-in procedure
Indicators	red OUTPUT LED green READY LED
Output	PNP or NPN; analog output
Output current	200 mA max.
Saturation voltage	1 V max. NPN vers., 2 V max. PNP vers.
Response time	50 μ s max. (mod. TL μ -4xx) 25 μ s max. (mod. TL μ -5xx)
Switching frequency	10 kHz max. (mod. TL μ -4xx) 20 kHz max. (mod. TL μ -5xx)
Connection	3 m shielded cable \varnothing 6.1 mm, M12 4-pole connector
Dielectric strength	500 Vac, 1 min between electronics and housing
Insulating resistance	>20 M Ω , 500 Vdc between electronics and housing
Electrical protection	class 1
Mechanical protection	IP67
Ambient light rejection	according to EN 60947-5-2
Vibrations	0,5 mm amplitude, 10 ... 55 Hz frequency, for every axis (EN60068-2-6)
Shock resistance	11 ms (30 G) 6 shock for every axis (EN60068-2-27)
Minimum spot dimension	1,5 x 5 mm (TL μ -x1x), 2 x 7 mm (TL μ -x6x), \varnothing 3 mm (TL μ -4xx/5xx)
Depth of field	\pm 3 mm (TL μ -x1x/4xx/5xx) / \pm 4 mm (TL μ -x6x)
Housing material	ZAMA
Lens material	glass
Operating temperature	-10 ... 55 °C
Storage temperature	-20 ... 70 °C
Weight	450 g max. cable vers., 310 g max. connector vers.

DIMENSIONS

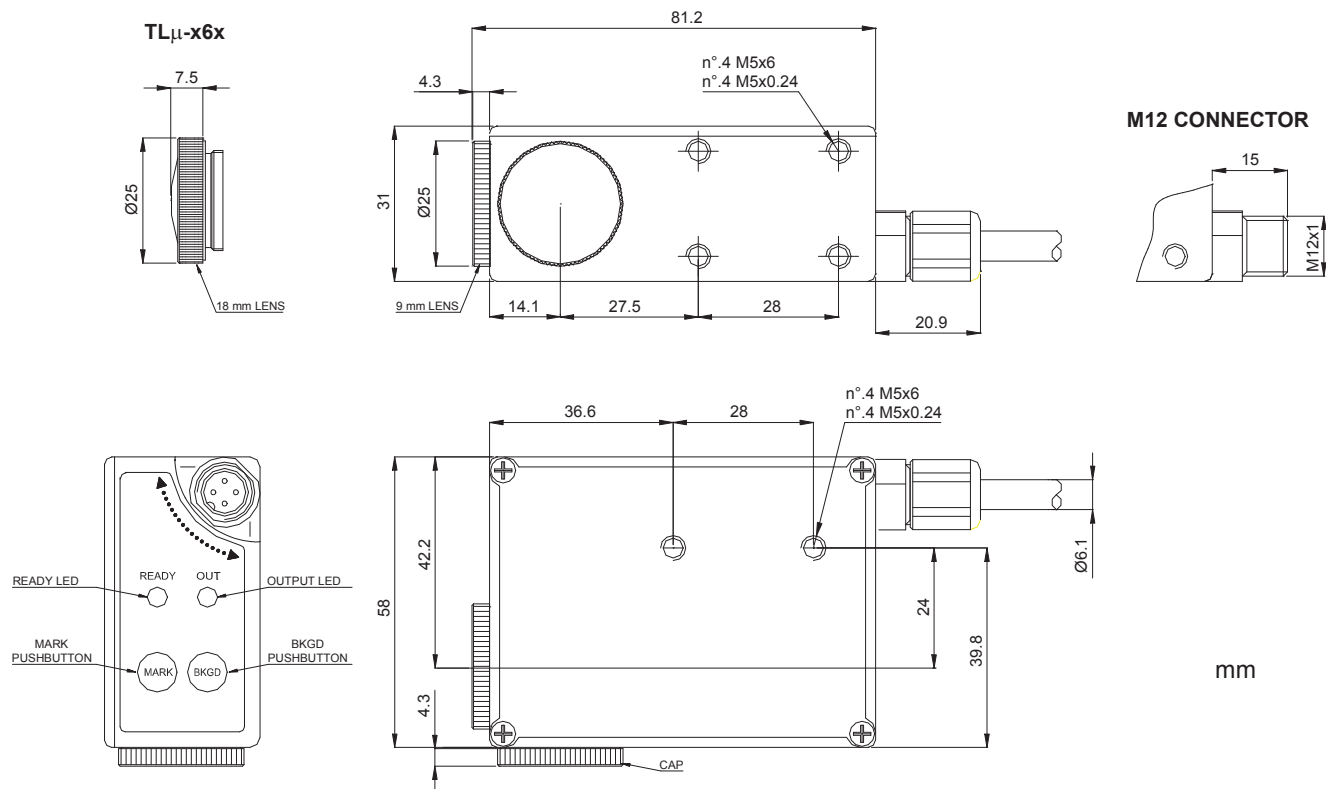

CONTRAST SENSORS

INDICATORS AND SETTINGS

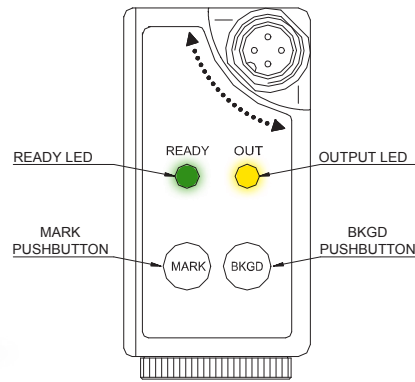

CONNECTIONS

CABLE

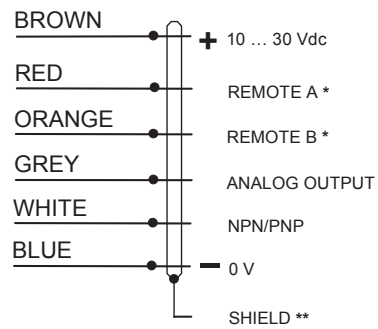

* = Connect the unused REMOTE wires to 0 V.

** = The cable shield is insulated from the sensor housing; it is recommended to connect the shield to 0 V.

M12 CONNECTOR

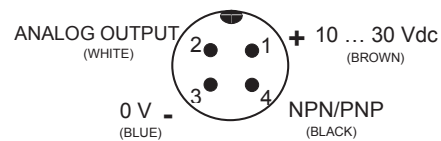

DETECTION DIAGRAMS

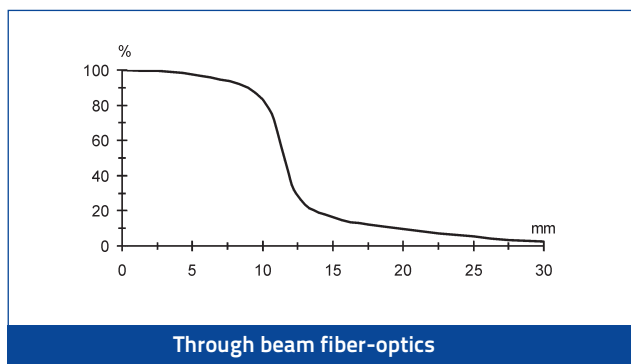
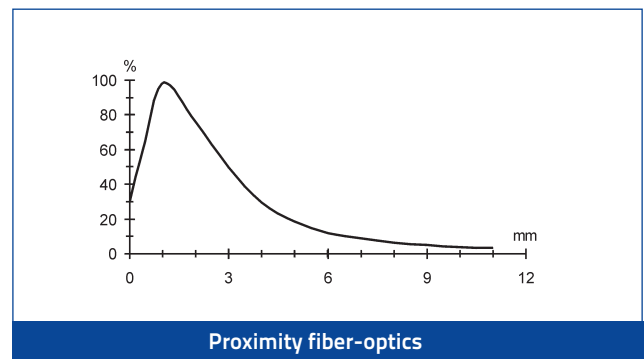
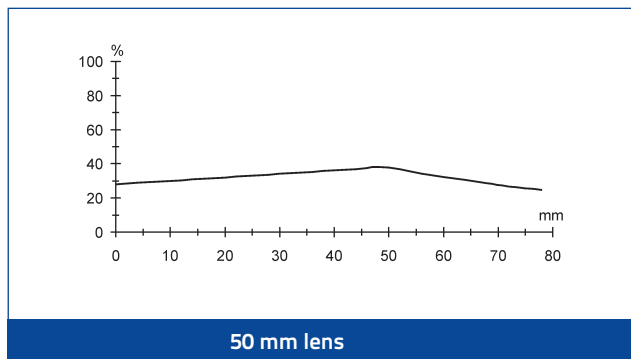
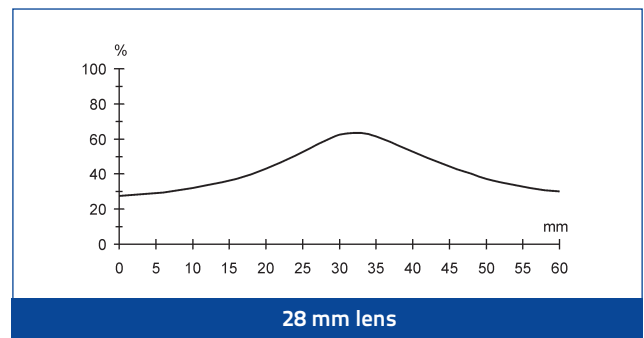
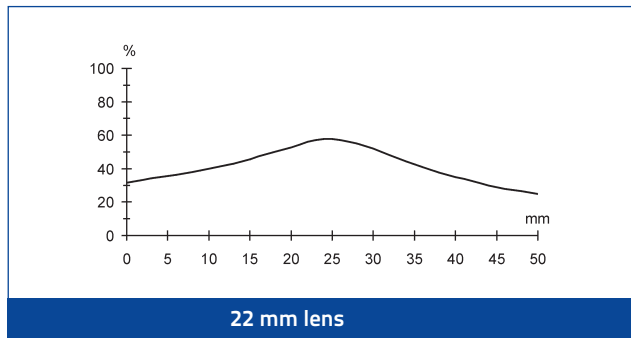
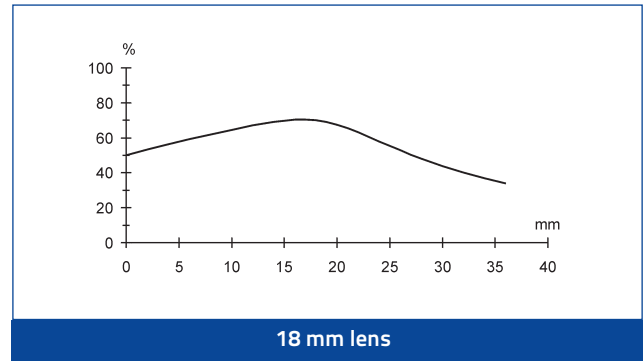
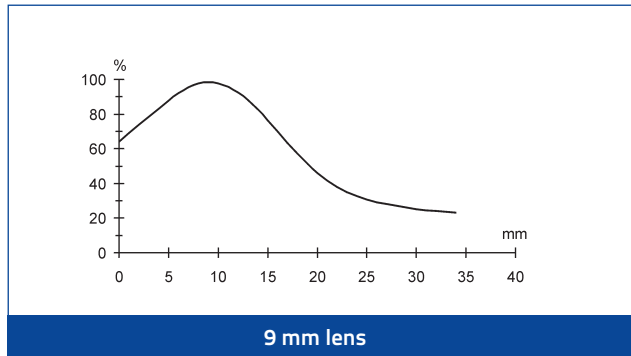

The detection diagrams indicate the typical operating distance.

CONTRAST SENSORS

MODEL SELECTION AND ORDER INFORMATION

OPTIC FUNCTION	EMISSION	OPTICS	CONNECTION	OUTPUT	MODEL	ORDER No.		
Contrast sensor	Red/Green (Vertical spot)	9 mm	3m Cable	NPN	TL μ -011	964401000		
				PNP	TL μ -111	964401080		
			M12 Connector	NPN	TL μ -015	964401020		
				PNP	TL μ -115	964401100		
			3m Cable	NPN	TL μ -011L	964401010		
				PNP	TL μ -111L	964401090		
	M12 Connector	NPN	TL μ -015L	964401030				
		PNP	TL μ -115L	964401110				
	Red/Green (Horizontal spot)	18 mm	M12 Connector	NPN	TL μ -065	964401060		
				PNP	TL μ -165	964401140		
	White (Circular spot)	9 mm	M12 Connector	NPN	TL μ -415C	954151330		
				PNP	TL μ -515C	954151360		
3m Cable			NPN	TL μ -411C	954151410			
			PNP	TL μ -511C	954151420			
Fiber optic contrast sensor			White	Fiber optics	M12 Connector	PNP	TL μ -545	954151380
						NPN	TL μ -445	954151350

ACCESSORIES

HI-RES LENS

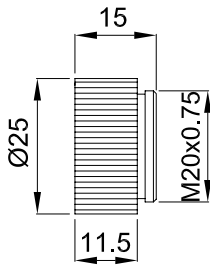

18 mm LENS

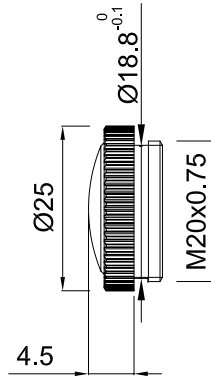

22 mm LENS

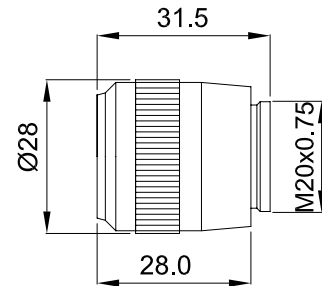

28 mm LENS

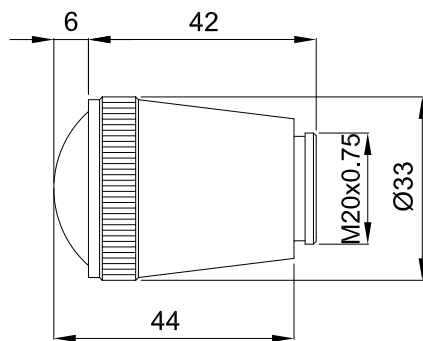

40 mm LENS

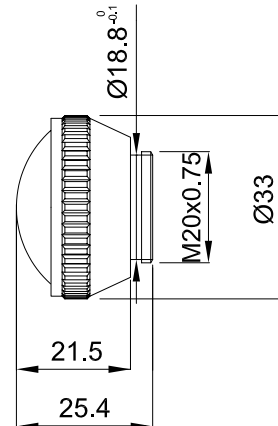

MODEL	DESCRIPTION	ORDER No.
Lens Hi-Res	additional focussing glass lens with 9 mm focus (*)	95ACC1050
Lens No.18	glass lens with 18 mm focus	95ACC2680
Lens No.22	glass lens with 22 mm focus	95ACC1100
Lens No.28	glass lens with 28 mm focus	890000194
Lens No.40	glass lens with 40 mm focus	95ACC2740
Lens No.50	glass lens with 50 mm focus	573030511
OF -30-5	plastic fiber-optic L 50 cm - point-shaped spot proximity	96B001070
OF -31-10	glass fiber-optic L 100 cm - point-shaped spot proximity	96B201000
OF -32-10	glass fiber-optic L 100 cm - rectangular spot proximity	96B211000
OF -33-10	glass fiber-optic L 100 cm - through beam	96B221000
OF -34-10	glass fiber-optic L 100 cm - horizontal spot 90° proximity	96B231000
OF -35-10	glass fiber-optic L 100 cm - vertical spot 90° proximity	96B24100

* focussing lens to screw between the sensor and the normal 9 mm lens

CABLES

TYPE	DESCRIPTION	LENGTH	MODEL	ORDER No.
Axial M12 Connector	4-pole, grey, P.V.C.	3 m	CS-A1-02-G-03	95A251380
		5 m	CS-A1-02-G-05	95A251270
		7 m	CS-A1-02-G-07	95A251280
		10 m	CS-A1-02-G-10	95A251390
	4-pole, P.U.R.	2 m	CS-A1-02-R-02	95A251540
		5 m	CS-A1-02-R-05	95A251560
Radial M12 Connector	4-pole, grey, P.V.C.	3 m	CS-A2-02-G-03	95A251360
		5 m	CS-A2-02-G-05	95A251240
		7 m	CS-A2-02-G-07	95A251245
		10 m	CS-A2-02-G-10	95A251260
	4-pole, P.U.R.	2 m	CS-A2-02-R-02	95A251550
		5 m	CS-A2-02-R-05	95A251570
Axial M12 Connector	4-pole, shielded, black, P.V.C.	3 m	CV-A1-22-B-03	95ACC1480
		5 m	CV-A1-22-B-05	95ACC1490
		10 m	CV-A1-22-B-10	95ACC1500
		15 m	CV-A1-22-B-15	95ACC2070
		25 m	CV-A1-22-B-25	95ACC2090
Radial M12 Connector	4-pole, shielded, black, P.V.C.	3 m	CV-A2-22-B-03	95ACC1540
		5 m	CV-A2-22-B-05	95ACC1550
		10 m	CV-A2-22-B-10	95ACC1560
Axial M12 Connector	4-pole, U.L., black, P.V.C.	3 m	CS-A1-02-U-03	95ASE1120
		5 m	CS-A1-02-U-05	95ASE1130
		10 m	CS-A1-02-U-10	95ASE1140
		15 m	CS-A1-02-U-15	95ASE1150
		25 m	CS-A1-02-U-25	95ASE1160
Radial M12 Connector	4-pole, black	Connector- not cabled	CS-A1-02-B-NC	G5085002
		Connector- not cabled	CS-A2-02-B-NC	G5085003

CONTRAST SENSORS

TL46

High performance contrast sensor for colored registration mark detection

- Fastest and accurate low jitter model (TL46-WJ)
- Wide-spectrum RGB or white LED emission
- 4 different models: basic, standard, enhanced, low jitter
- Automatic, manual and dynamic settings
- 15, 20, 30 or 50 kHz switching frequencies
- Very low jitter down to 7µs (TL46-WJ...)
- NPN/PNP and analog outputs
- Standard mounting, M12 connector rotatable to 5 positions

APPLICATIONS

- Packaging and labeling machinery
- Beverage/Food/Cosmetic/Pharmaceutical industries
- Printing machinery
- Flexographic printing machinery



(*) ATEX II 3DG

TL46

Contrast sensor		9 ±3 mm 18 mm (Lens No.18 glass) 22 mm (Lens No.22 glass) 28 mm (Lens No.28 glass) 40 mm (Lens No.40 glass)
Switching frequency		15 kHz 20 kHz 30 kHz 50 kHz
Jitter		< 7µs (TL46-WJ) 16µs (TL46-WLF) >25µs (TL46-W/WL)
Light emission		RGB LED white LED Red LED
Setting		push buttons trimmer
Power supply	Vdc	10...30 V
	Vac	
	Vac/dc	
Output	PNP	▪
	NPN	▪
	NPN/PNP	▪
	relay	▪ (see Technical Data Table)
	other	0...5 V Analog Output
Connection	cable	▪ (see Technical Data Table)
	connector	▪
	pig-tail	
Approximate dimensions (mm)		31x81x58
Housing material		Aluminium
Mechanical protection		IP67

TECHNICAL DATA

Power supply	10 ... 30 Vdc (limit values)
Ripple	2 Vpp max.
Consumption (output current excluded)	40 mA max. at 24 Vdc (mod. TL46-A) 50 mA max. at 24 Vdc (mod. TL46-W/WJ) 85 mA max. at 24 Vdc 24 Vdc with bargraph ON in threshold adjustment mode, 55 mA max at 24 Vdc with bargraph OFF in normal functioning mode (mod. TL46-WL) 35 mA max. at 24 Vdc (mod. TL46-WLF)
Light emission	white LED 400-700 nm (mod. TL46-A-4xx) red LED 630 nm (mod. TL46-A-6xx) blu LED 465nm/green LED 520 nm/red LED 630 nm (mod. TL46-W/WL/WLF/WJ)
Detection Distance	9 ±3 mm 18 mm (Lens No.18 glass) 22 mm (Lens No.22 glass) 28 mm (Lens No.28 glass) 40 mm (Lens No.40 glass)
Minimum spot dimension	1,5 x 5 mm 0,8x4mm (TL46-WJ)
Depth of field	± 3 mm
Response time	33 µs (mod. TL46-W) 25 µs (mod. TL46-A/WL) 16 µs (mod. TL46-WLF) 10 µs (mod. TL46-WJ)
Switching frequency	15 kHz (mod. TL46-W) 20 kHz (mod. TL46-A/WL) 30 kHz (mod. TL46-WLF) 50 kHz (mod. TL46-WJ)
Jitter	7 µs (mod. TL46-WJ)
Setting	SET push-buttons (mod. TL46-W/WL/WLF) sensitivity trimmer (mod. TL46-A)
Operating mode	DARK/LIGHT selection by switch (mod. TL46-A) automatic DARK/LIGHT selection (mod. TL46-W/WL/WJ) automatic DARK/LIGHT selection in the target/background detection, selectable via wire in the dynamic detection (mod. TL46-WLF)
Indicators	yellow OUTPUT LED green READY LED, orange DELAY LED and KEYLOCK (Mod TL46-W/WJ) green READY LED, 4-digit display/DELAY LED/KEYLOCK LED (mod. TL46-WLF) orange ARROWS (mod. TL46-A), DELAY LED and KEYLOCK LED 5-segment bargraph (mod. TL46-WL)
Dark/light selection	Switch Automatic Automatic/manual; remote/dynamic
Delay	0...20ms selectable via delay input 0...100ms programmed
Auxiliary function	Keylock Fine Hysteresis regulation
Indicators	
Output	PNP (mod. TL46-WJ); PNP or NPN; PNP/NPN (mod. TL46-W/WL/WLF); analog output (mod. TL46-A/W/WL)
Output current	100mA
Saturaton Voltage	=<2V
Analogue Out	0,5...5,5V ±10%; 2V on white target 90% 1...3V ±10%(white 90%) ; 5,5V max
Analogue out impedance	2,2 kΩ (short circuit protection)
Connection	M12 5-pole connector
Dielectric strength	500 Vac, 1 min between electronics and housing
Insulating resistance	>20 MΩ, 500 Vdc between electronics and housing
Electrical protection	class 2, double insulation
Protection device	Reverse polarity protection, overload and short circuit protection
Mechanical protection	IP67
Ambient light rejection	according to EN 60947-5-2
Vibrations	0,5 mm amplitude, 10 ... 55 Hz frequency, for every axis (EN60068-2-6)
Shock resistance	11 ms (30 G) 6 shock for every axis (EN60068-2-27)
Housing material	aluminium
Lens material	mirror (mod. TL46-A), glass (mod. TL46-W/WL/WLF/WJ)
Operating temperature	-10 ... 55 °C
Storage temperature	'-20 ... 70 °C
Weight	170 g max.

CONTRAST SENSORS

DIMENSIONS

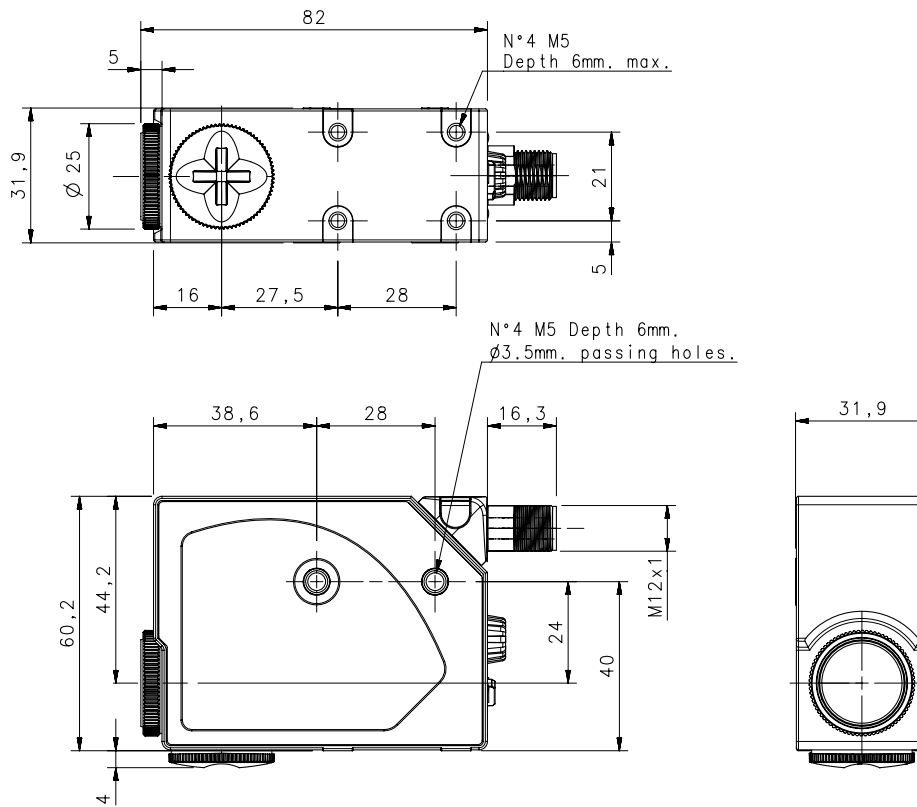

TL46-A

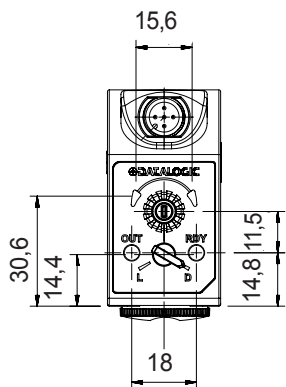

TL46-W/TL46-WJ

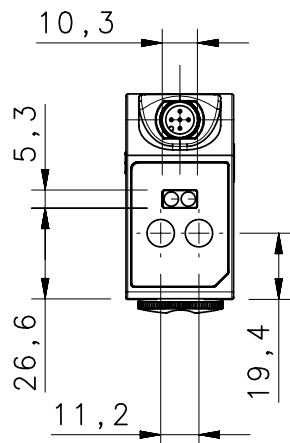

TL46-WL

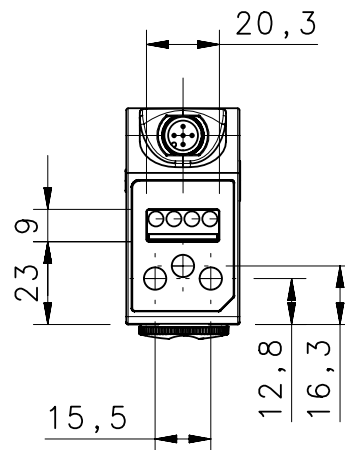

TL46-WLF

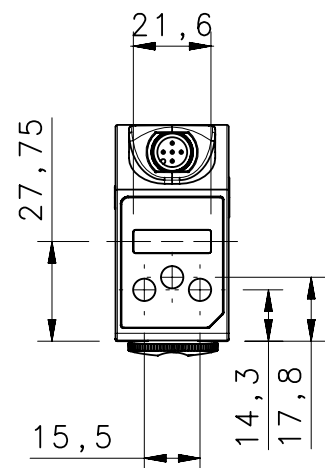

INDICATORS AND SETTINGS

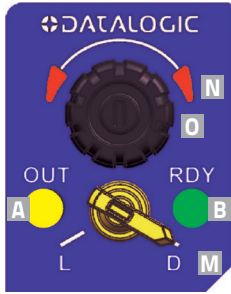

**TL46-A
TRIMMER**

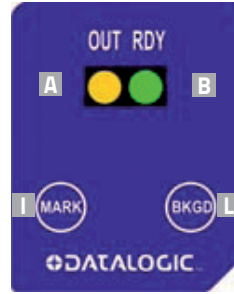

**TL46-W
BASE**

**TL46-WJ
LOW JITTER**

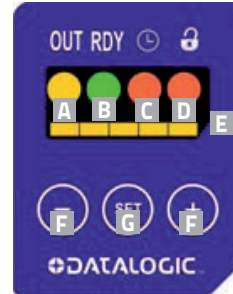

**TL46-WL
STANDARD**

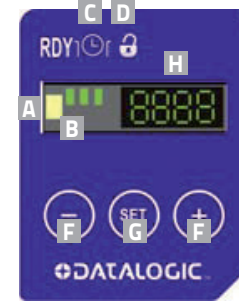

**TL46-WLF
ENHANCED**

- | | | |
|-----------------------------|---------------------------|--------------------------------------|
| A yellow OUTPUT LED | F +/- push-buttons | L BKGD push-button |
| B green READY LED | G SET push-button | M Light/Dark Switch |
| C orange DELAY LED | H Display | N Orange Indicators Arrows |
| E orange KEYLOCK LED | I MARK push-button | O Sensitivity Adjustment Knob |
| D Bargraph | | |

CONNECTIONS

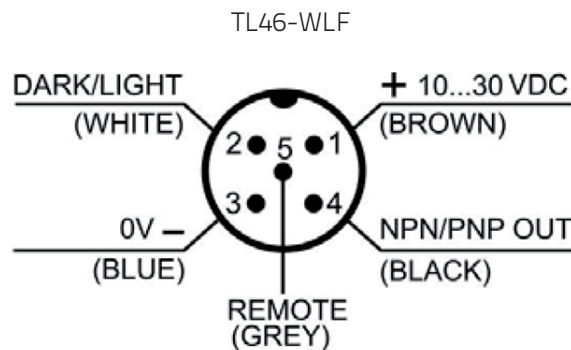
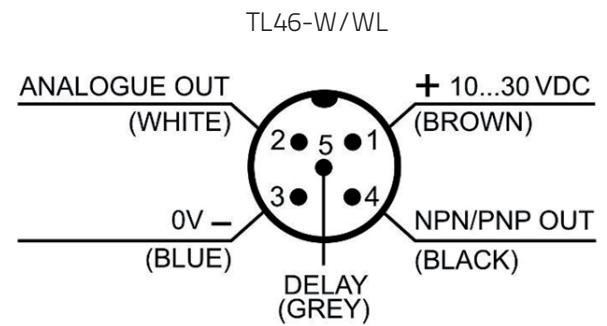
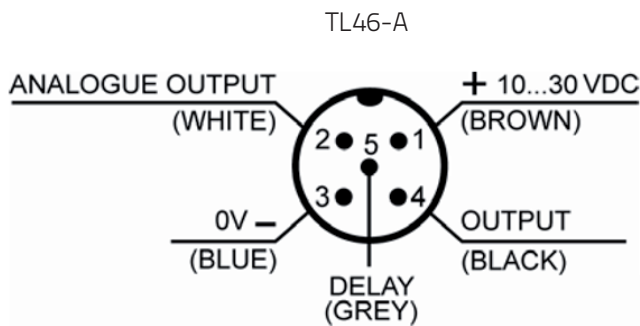

CONTRAST SENSORS

READING DIAGRAMS

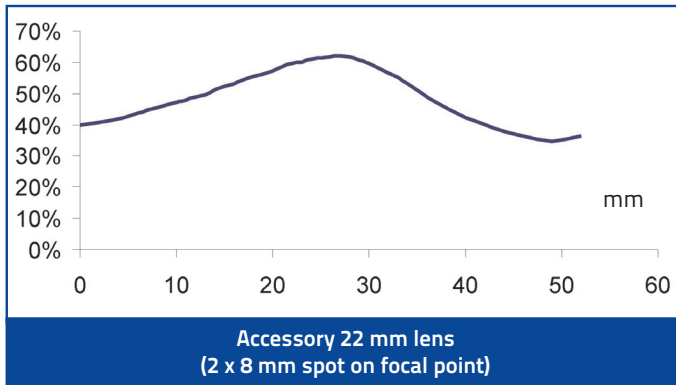
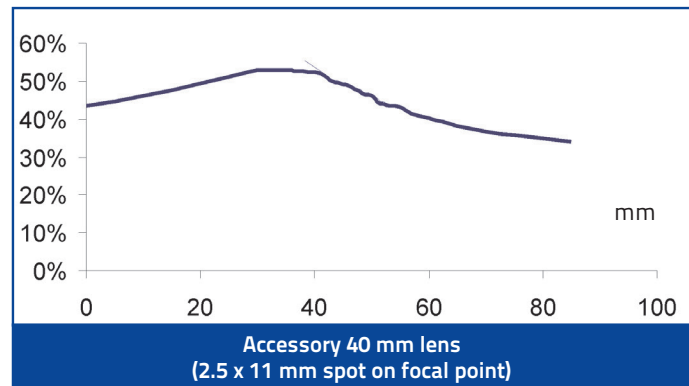
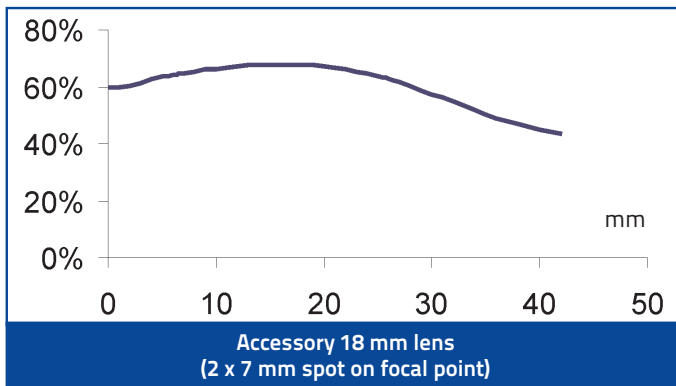
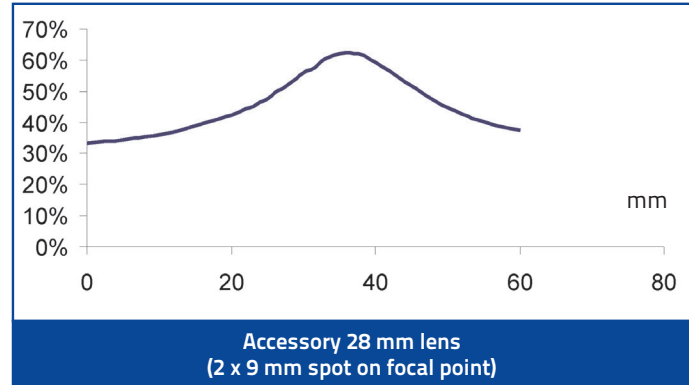
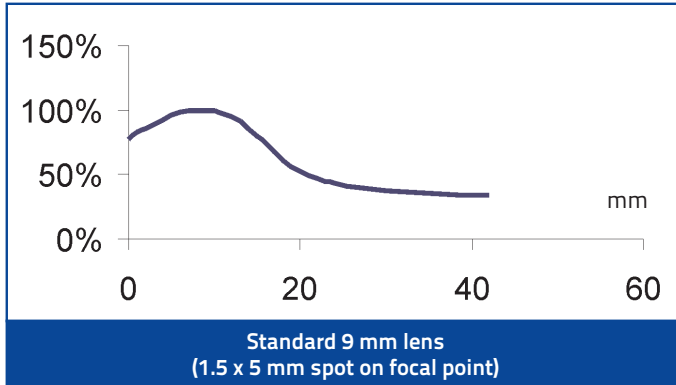

VERTICAL SPOT



HORIZONTAL SPOT



Horizontal spot is present in the TL46 models with final '-L' suffix

MODEL SELECTION AND ORDER INFORMATION

OPTIC FUNCTION	SETTING & INDICATORS	EMISSION	OUTPUT	MODEL	ORDER No.	
Contrast sensor	Trimmer 2 LEDs	WHITE vertical spot	PNP	TL46-A-415	954601070	
		RED vertical spot	NPN	TL46-A-425	954601080	
			PNP	TL46-A-615	954601090	
		Push-buttons 2 LEDs	R.G.B. vertical spot	PNP/NPN	TL46-W-815	954601000
	R.G.B. horizontal spot		TL46-W-815L		954601010	
	Push buttons 4 LEDs bargraph	R.G.B. vertical spot	TL46-WL-815		954601020	
		R.G.B. horizontal spot	TL46-WL-815L		954601030	
	Push buttons 4 LEDs display	R.G.B. vertical spot	TL46-WLF-815		954601040	
		R.G.B. horizontal spot	TL46-WLF-815L		954601050	
		R.G.B. vertical spot	PNP		TL46-WJ-815	954601110
		R.G.B. horizontal spot	TL46-WJ-815L		954601120	

ACCESSORIES

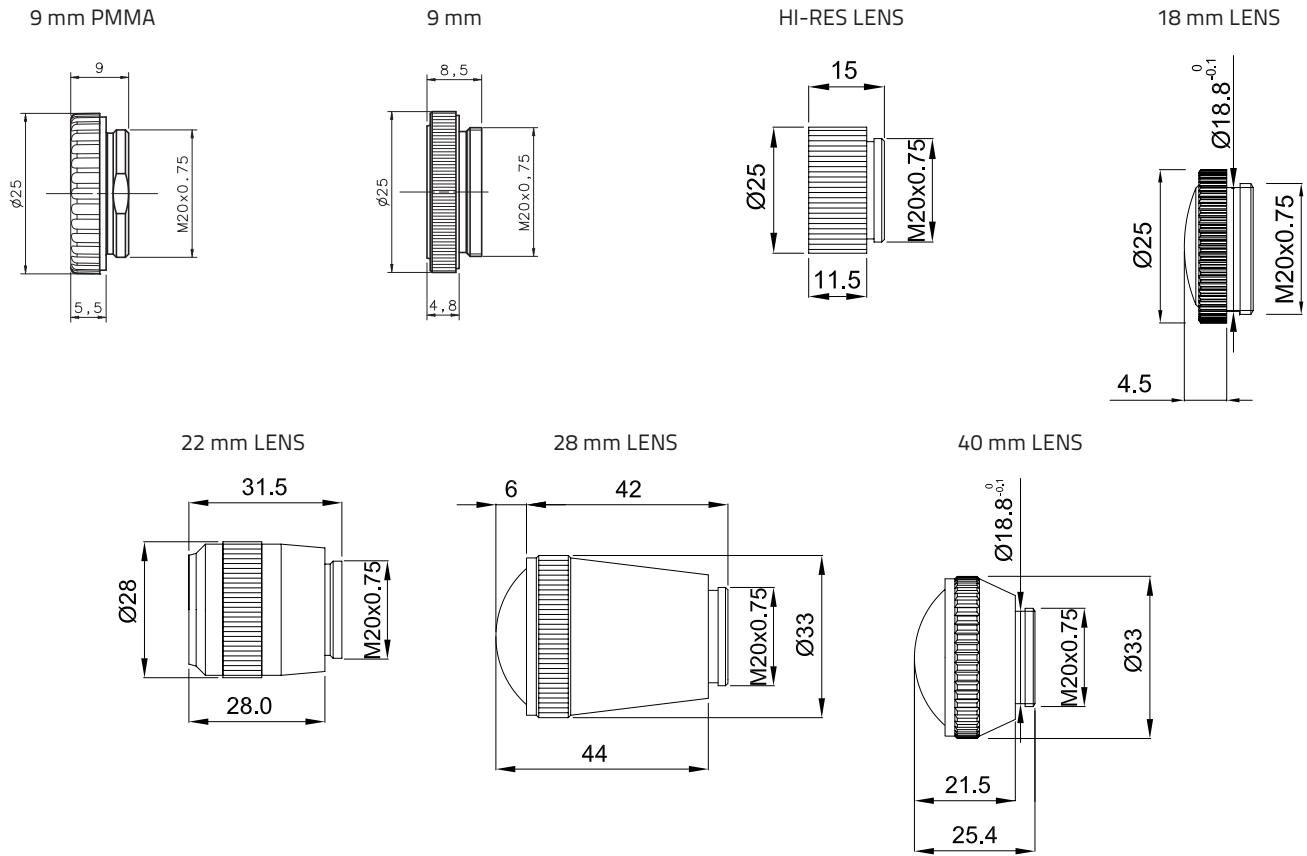

MODEL	DESCRIPTION	ORDER No.
Lens No.9	glass lens with 9 mm focus	95ACC2670
Lens No.9 PMMA	plastic lens with 9 mm focus	95ACC2540
Lens Hi-Res	additional focussing glass lens with 9 mm focus (*)	95ACC1050
Lens No.18	glass lens with 18 mm focus	95ACC2680
Lens No.22	glass lens with 22 mm focus	95ACC1100
Lens No.28	glass lens with 28 mm focus	890000194
Lens No.40	glass lens with 40 mm focus	95ACC2740

* focussing lens to screw between the sensor and the normal 9 mm lens

CABLES

TYPE	DESCRIPTION	LENGTH	MODEL	ORDER No.
Axial M12 Connector	5-pole, grey, P.V.C.	3 m	CS-A1-03-G-03	95ACC2110
		5 m	CS-A1-03-G-05	95ACC2120
		10 m	CS-A1-03-G-10	95ACC2140
	5-pole, U.L., black, P.V.C.	3 m	CS-A1-03-U-03	95ASE1170
		5 m	CS-A1-03-U-05	95ASE1180
		10 m	CS-A1-03-U-10	95ASE1190
		15 m	CS-A1-03-U-15	95ASE1200
		25 m	CS-A1-03-U-25	95ASE1210
		50 m	CS-A1-03-U-50	95A252700

LUMINESCENCE SENSORS

LD46

Luminescence sensor line in standard metal housing

- UV high power LED emission
- High sensitivity on fluorescent marks
- 10 - 50 mm detection distance
- 2 kHz switching frequency
- NPN/PNP and 0-5 V analog outputs



APPLICATIONS

- Packaging and labeling machinery
- Food, Cosmetic and Pharmaceutical
- Ceramic tiles selection and sorting



(*) ATEX II 3DG

LD46		
Luminescence sensor		10...20 mm (LD46-UL-715) 20...40 mm (LD46-UL-755) 30...50 mm (LD46-UL-735)
Spot dimension		2x8 mm at 10 mm 3x11 mm at 24 mm 4x15 mm at 50 mm
Switching frequency		2 kHz
Response Time		250 µs
Light emission		UV-HP LED
Setting		push buttons
Power supply	Vdc	15...30 V
	Vac	
	Vac/dc	
Output	PNP	
	NPN	
	NPN/PNP	▪
	relay	
	other	0...5 V Analog output
Connection	cable	
	connector	▪
	pig-tail	
Approximate dimensions (mm)		31x81x58
Housing material		aluminium
Mechanical protection		IP67

TECHNICAL DATA

Power supply	15 ... 30 Vdc (limit values)
Ripple	2 Vpp max.
Consumption (output current excluded)	50 mA max. at 24 Vdc
Light emission	UV LED 375 nm
Setting	SET push-buttons
Indicators	yellow OUTPUT LED green READY LED orange DELAY LED and KEYLOCK LED 5-segment bargraph
Output	PNP/NPN; analog output
Output current	100 mA max.
Saturation voltage	2 V max.
Response time	250 µs
Switching frequency	2 kHz
Connection	M12 5-pole connector
Dielectric strength	500 Vac, 1 min between electronics and housing
Insulating resistance	>20 MΩ, 500 Vdc between electronics and housing
Electrical protection	class 2, double insulation
Mechanical protection	IP67
Ambient light rejection	according to EN 60947-5-2
Vibrations	0,5 mm amplitude, 10 ... 55 Hz frequency, for every axis (EN60068-2-6)
Shock resistance	11 ms (30 G) 6 shock for every axis (EN60068-2-27)
Minimum spot dimension	2 x 8 mm at 10 mm (mod. LD46-UL-715) 3x11 mm at 24 mm (mod. LD46-UL-755) 4x15 mm at 50 mm (mod. LD46-UL-735)
Housing material	aluminium
Lens material	glass
Operating temperature	-10 ... 55 °C
Storage temperature	-20 ... 70 °C
Weight	180 g max.

DIMENSIONS

**LD46-UL-735
(40mm LENS)**

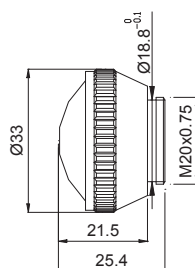

**LD46-UL-755
(22mm LENS)**

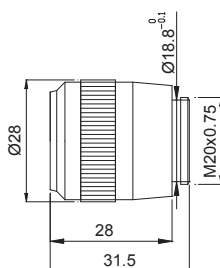

**LD46-UL-715
(9mm LENS)**

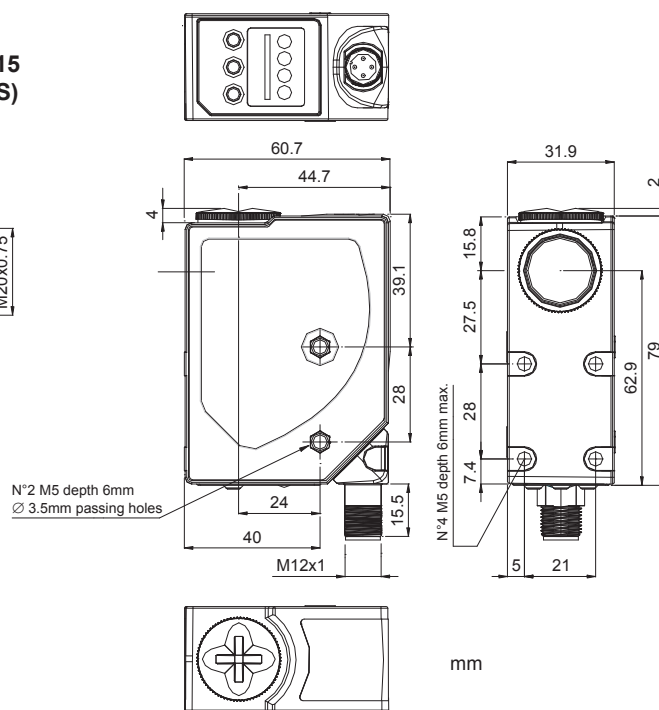
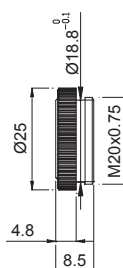

mm

LUMINESCENCE SENSORS

INDICATORS AND SETTINGS

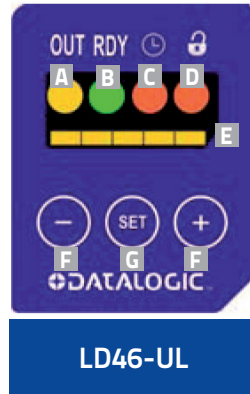

- A** yellow OUTPUT LED
- B** green READY LED
- C** orange DELAY LED
- D** orange KEYLOCK LED
- E** Bargraph
- F** +/- push-buttons
- G** SET push-button

LD46-UL

CONNECTIONS

M12 CONNECTOR

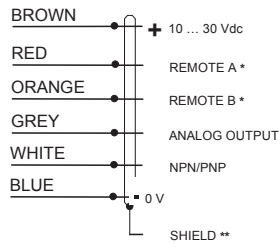

DETECTION DIAGRAMS

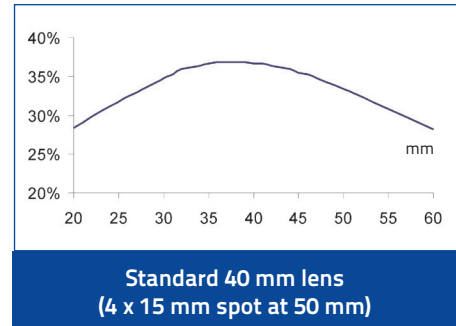
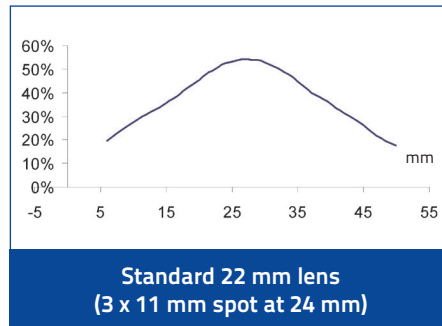
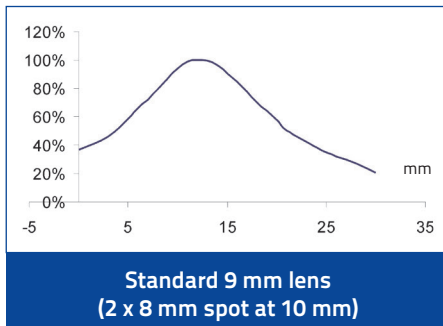

MODEL SELECTION AND ORDER INFORMATION

OPTIC FUNCTION	EMISSION	CONNECTION	OUTPUT	MODEL	ORDER No.
Luminescence sensor	10-20 mm Vertical spot	M12 Connector	NPN/PNP	LD46-UL-715	955201000
	20-40 mm Vertical spot			LD46-UL-755	955201010
	30-50 mm Vertical spot			LD46-UL-735	955201020

ACCESSORIES

40 mm LENS
(LD46-UL-735)

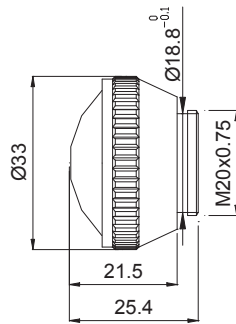

22 mm LENS
(LD46-UL-755)

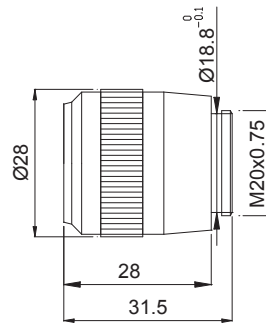

9 mm LENS
(LD46-UL-715)

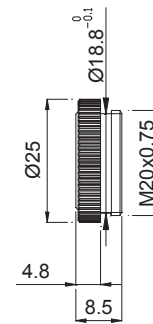

MODEL	DESCRIPTION	ORDER No.
Lens No.9	glass lens with 9 mm focus	95ACC2670
Lens No.22	glass lens with 22 mm focus	95ACC1100
Lens No.40	glass lens with 40 mm focus	95ACC2740

CABLES

TYPE	DESCRIPTION	LENGTH	MODEL	ORDER No.
Axial M12 Connector	5-pole, grey, P.V.C.	3 m	CS-A1-03-G-03	95ACC2110
		5 m	CS-A1-03-G-05	95ACC2120
		10 m	CS-A1-03-G-10	95ACC2140
	5-pole, U.L., black, P.V.C.	3 m	CS-A1-03-U-03	95ASE1170
		5 m	CS-A1-03-U-05	95ASE1180
		10 m	CS-A1-03-U-10	95ASE1190
		15 m	CS-A1-03-U-15	95ASE1200
		25 m	CS-A1-03-U-25	95ASE1210
		50 m	CS-A1-03-U-50	95A252700

COLOR & CONTRAST SENSORS

S65

Advanced color and contrast sensors in compact case

Color S65-V:

- 3 independent NPN or PNP outputs and RS 485 serial interface
- 3 channel color sensor with 10 tolerance levels
- Wide spectrum white light LED emission and RGB photo-receiver
- 2 push button setting with 4 digit display indicator

Contrast S65-W:

- High 12 bit resolution and 30 kHz switching frequency
- PNP or NPN output and RS 485 serial interface



APPLICATIONS

- Packaging lines
- Contrast reading
- Automatic machine



S65		
Contrast sensor		12...20 mm (S65-W)
Color sensor		5...45 mm (S65-V)
Switching frequency		30 kHz (S65-W)
		500 Hz (S65-V19 vers.)
		1,5 kHz (S65-V09 vers.)
Light emission		white LED
Serial interface		RS485
Setting		push-buttons
Power supply	Vdc	10...30 V
	Vac	
	Vac/dc	
Output	PNP	▪
	NPN	▪
	NPN/PNP	
	relay	
	other	0...5 V Analog output (S65-W)
Connection	cable	
	connector	▪
	pig-tail	
Approximate dimensions (mm)		50x50x25
Housing material		ABS
Mechanical protection		IP67

TECHNICAL DATA

Power supply	10 ... 30 Vdc (limit values)
Ripple	2 Vpp max.
Consumption (output current excluded)	50 mA max. at 24 Vdc (mod. S65-W) 60 mA max. at 24 Vdc (mod. S65-V)
Light emission	white LED 400-700 nm
Setting	SET push-buttons SEL push-buttons (mod. S65-V)
Indicators	yellow OUTPUT LED green 4-digit display, 3 OUTPUT STATUS LEDs (S65-V), STABILITY and 2 OUTPUT DELAY LEDs (mod. S65-W)
Output	1 PNP or NPN; analog output (mod. S65-W) 3 PNP or NPN; RS485 serial interface (mod. S65-V)
Output current	100 mA max.
Saturation voltage	2 V max.
Response time	5 ms (norm) and 1 ms (fast) (mod. S65-V19) 335 μ s (mod. S65-V09) 16 μ s (mod. S65-W)
Switching frequency	100 Hz (norm) and 500 Hz (fast) (mod. S65-V19) 1,5 kHz (mod. S65-V09) 30 kHz (mod. S65-W)
Connection	M12 5-pole connector (mod. S65-W standard vers.), M12 8-pole connector (mod. S65-W vers. with RS485 serial interface) M12 8-pole connector (mod. S65-V)
Dielectric strength	500 Vac, 1 min between electronics and housing
Insulating resistance	>20 M Ω , 500 Vdc between electronics and housing
Electrical protection	class 2
Mechanical protection	IP67
Ambient light rejection	according to EN 60947-5-2
Vibrations	0,5 mm amplitude, 10 ... 55 Hz frequency, for every axis (EN60068-2-6)
Shock resistance	11 ms (30 G) 6 shock for every axis (EN60068-2-27)
Minimum spot dimension	3x1 mm at 19 mm (mod. S65-W) \varnothing 4 mm (mod. S65-V)
Depth of field	\pm 2 mm (mod. S65-W)
Housing material	ABS
Lens material	window and lenses in glass
Operating temperature	-10 ... 55 °C
Storage temperature	-20 ... 70 °C
Weight	100 g max.

DIMENSIONS

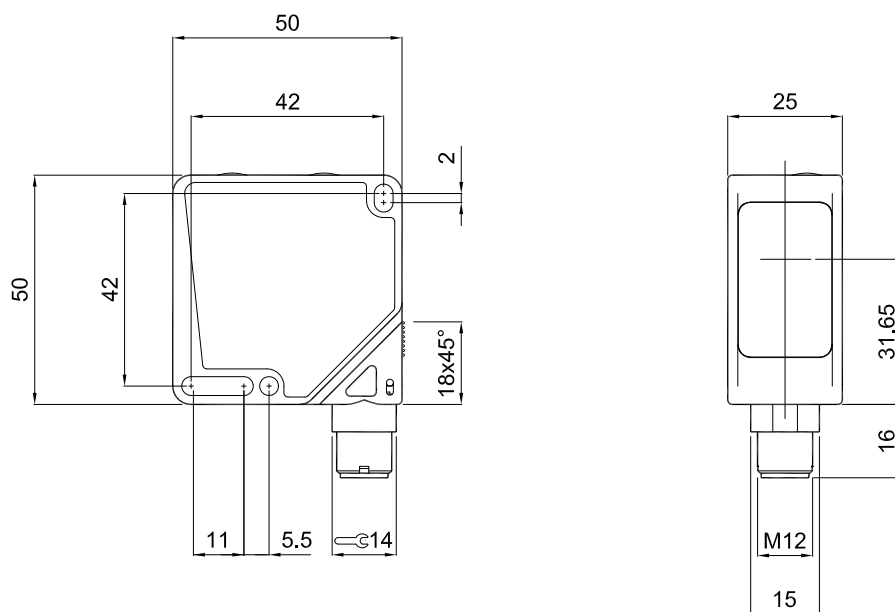

COLOR & CONTRAST SENSORS

S65-W

INDICATORS AND SETTINGS S65-W

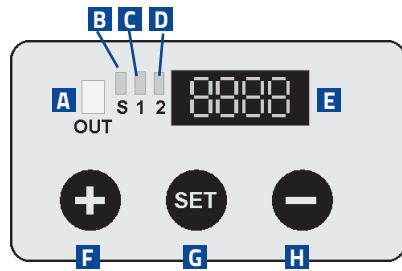

- A** Output status LED
- B** Stability LED
- C** Delay ON LED
- D** Delay OFF LED
- E** 4-digit display
- F** +/- push-buttons
- G** SET push-button
- H** M12 connector output, orientable on two positions

DETECTION DIAGRAMS S65-W

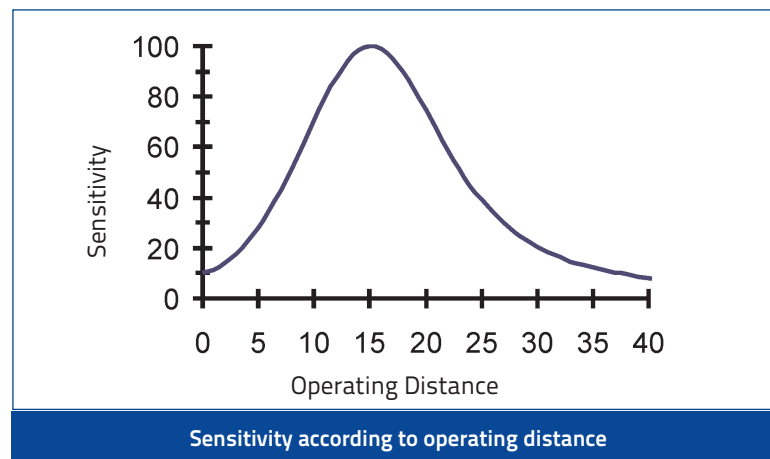

S65-V

INDICATORS AND SETTINGS S65-V

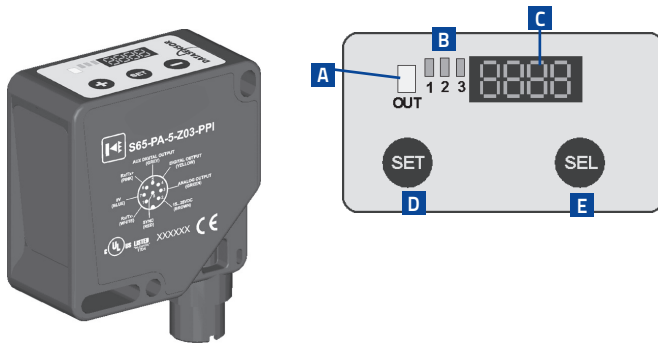

- A** Output 'OR' function LED
- B** Output status LEDs
- C** 4 digit display
- D** SET push-button
- E** SEL push-button
- F** +/- selection push-buttons
- G** M12 connector output, orientable on two positions

DETECTION DIAGRAMS S65-V

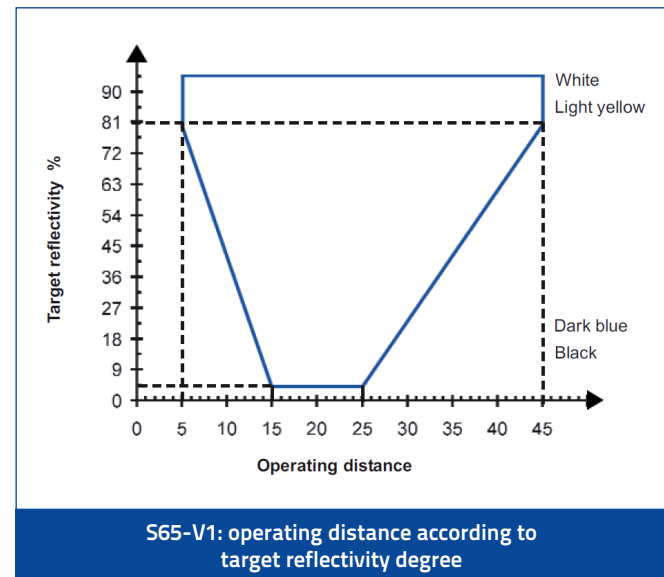
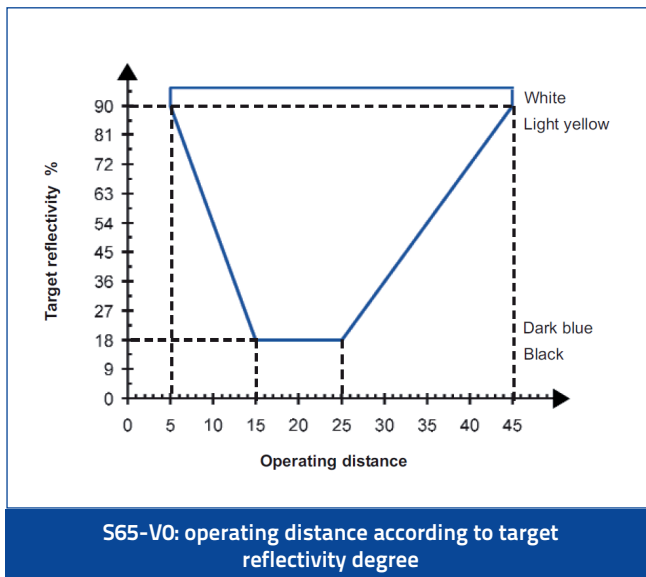

COLOR & CONTRAST SENSORS

Color sensor S65-V

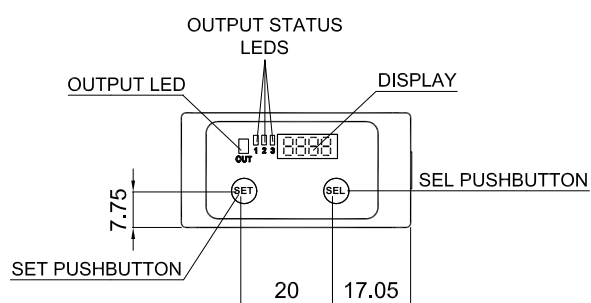

Contrast sensor S65-W

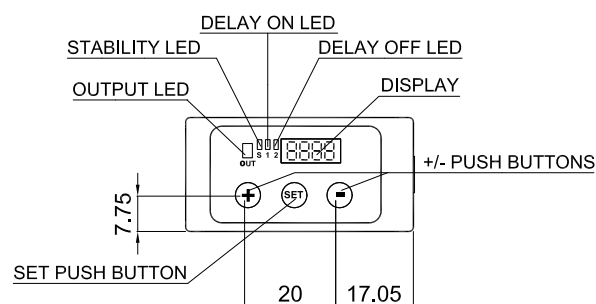

mm

CONNECTIONS

M12 CONNECTOR - COLOR SENSOR S65-V

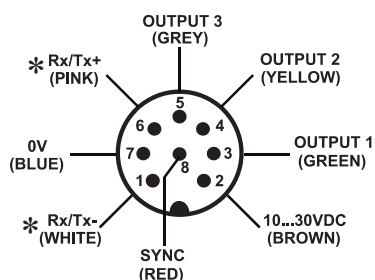

* Available only for version with RS485 serial connection (S65-PA-5-V09-xxxZ).

M12 CONNECTOR - CONTRAST SENSOR S65-W

standard versions

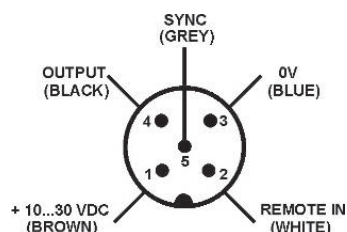

versions with RS485 serial interface

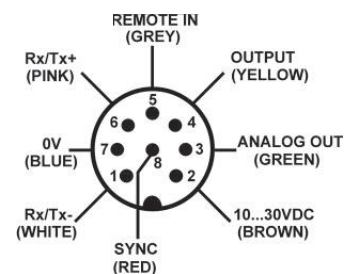

MODEL SELECTION AND ORDER INFORMATION

OPTIC FUNCTION	HOUSING	CONNECTION	OUTPUT	MODEL	ORDER No.
Color sensor	335 μ s	M12 8-pole Connector	PNP, RS485	S65-PA-5-V09-PPPZ	956251000
			NPN, RS485	S65-PA-5-V09-NNNZ	956251010
			PNP	S65-PA-5-V09-PPP	956251020
			NPN	S65-PA-5-V09-NNN	956251030
	5 ms (norm) or 1 ms (fast)		PNP, RS485	S65-PA-5-V19-PPPZ	956251080
			NPN, RS485	S65-PA-5-V19-NNNZ	956251090
			PNP	S65-PA-5-V19-PPP	956251100
			NPN	S65-PA-5-V19-NNN	956251110
Contrast sensor	16 μ s	M12 5-pole Connector	NPN	S65-PA-5-W09-NH	954201000
		M12 8-pole Connector	NPN, RS485	S65-PA-5-W09-NHZ	954201010
		M12 5-pole Connector	PNP	S65-PA-5-W09-PH	954201020
		M12 8-pole Connector	PNP, RS485	S65-PA-5-W09-PHZ	954201030

ACCESSORIES

ST-5020

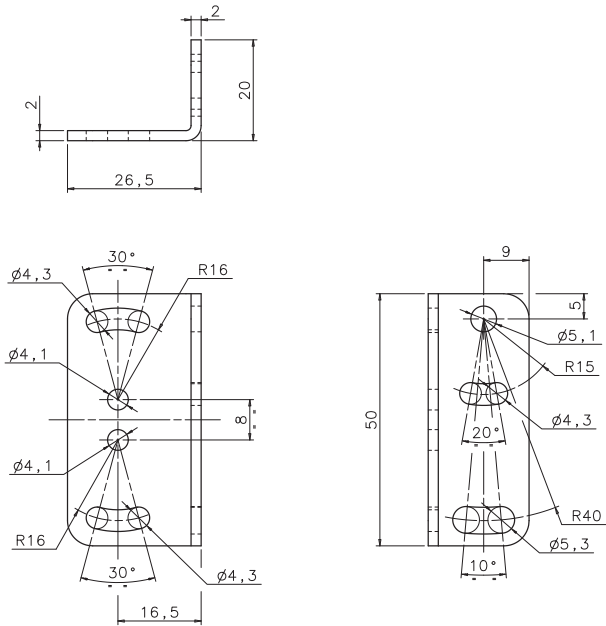

ST-5021

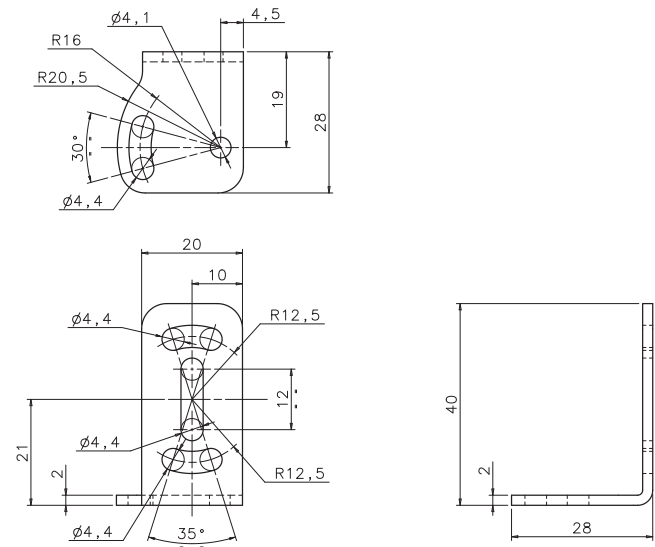

MODEL	DESCRIPTION	ORDER No.
ST-5020	mounting bracket 50 x 27 x 20 mm	95ACC5330
ST-5021	mounting bracket 20 x 40 x 28 mm	95ACC5340

CABLES

TYPE	DESCRIPTION	LENGTH	MODEL	ORDER No.
Axial M12 connector	5-pole, grey, P.V.C.	3 m	CS-A1-03-G-03	95ACC2110
		5 m	CS-A1-03-G-05	95ACC2120
		10 m	CS-A1-03-G-10	95ACC2140
	5-pole, U.L., black, P.V.C.	3 m	CS-A1-03-U-03	95ASE1170
		5 m	CS-A1-03-U-05	95ASE1180
		10 m	CS-A1-03-U-10	95ASE1190
		15 m	CS-A1-03-U-15	95ASE1200
		25 m	CS-A1-03-U-25	95ASE1210
		50 m	CS-A1-03-U-50	95A252700
	8-pole, black, P.V.C.	3 m	CS-A1-06-B-03	95ACC2260
5 m		CS-A1-06-B-05	95ACC2270	
10 m		CS-A1-06-B-10	95ACC2280	
Radial M12 Connector	8-pole, shielded, black, P.V.C.	3 m	CV-A2-26-B-03	95ACC1600
		5 m	CV-A2-26-B-05	95ACC1610
		10 m	CV-A2-26-B-10	95ACC1620
Axial M12 Connector	8-pole, shielded, black, P.V.C.	3 m	CV-A1-26-B-03	95ACC1510
		5 m	CV-A1-26-B-05	95ACC1520
		10 m	CV-A1-26-B-10	95ACC1530
		15 m	CV-A1-26-B-15	95ACC2080
		25 m	CV-A1-26-B-25	95ACC2100
		50 m	CV-A1-26-B-50	95A252710
	8-pole, U.L., black, P.V.C.	3 m	CS-A1-06-U-03	95ASE1220
		5 m	CS-A1-06-U-05	95ASE1230
		10 m	CS-A1-06-U-10	95ASE1240
		15 m	CS-A1-06-U-15	95ASE1250
		25 m	CS-A1-06-U-25	95ASE1260
8-pole, black	Connector-not cabled	CS-A1-06-B-NC	95ACC2550	

AREA SENSORS

AS1

AREAscan™ high-resolution detection photoelectric light grids

- Crossed beam area sensors
- 100mm controlled height
- Adjustment trimmer
- Optical or wire synchronism
- Scan Mode input

APPLICATIONS

- Processing lines
- Food, Cosmetic and Pharmaceutical
- Electronics and mechanical assembling
- Conveyor lines and sorting systems



AS1		
Area sensing	100 mm	
Operating Distance	0,3...2,1 m (AS1-LD) 0,8...3 m (AS1-HD)	
Resolution	Flat: 0,2x75mm Cylindrical: Ø 6mm (AS1-HR) Flat: 0,2x200mm Cylindrical: Ø18mm (AS1-SR)	
Response Time	1,75 ms (AS1-SR) 2,75...8 ms (AS1-HR)	
Light emission	IR LED	
Power supply	Vdc	24 V
	Vac	
	Vac/dc	
Output	PNP	▪
	NPN	
	NPN/PNP	
	relay	
	other	
Connection	cable	
	connector	▪
	pig-tail	
Approximate dimensions (mm)	22x43x150	
Housing material	aluminium	
Mechanical protection	IP65	

TECHNICAL DATA

Power supply	24 Vdc ± 15%
Consumption on emitter unit (TX)	150 mA max.
Consumption on receiver unit (RX)	40 mA max. load excluded
Light emission	IR LED 880 nm
Setting	adjustment trimmer (mod. AS1...P)
Indicators	yellow OUTPUT LED green POWER ON LED
Output	PNP
Output current	100 mA max.
Saturation voltage	1,5 V max.
Response time	2,75 - 8 ms (mod. AS1-HR) 1,75 ms (mod. AS1-SR)
Connection	M12 4-pole connector (TX), M12 5-pole connector (RX)
Dielectric strength	500 Vac, 1 min between electronics and housing
Insulating resistance	>20 MΩ, 500 Vdc between electronics and housing
Mechanical protection	IP65 (EN 60529)
Vibrations	0,5 mm amplitude, 10 ... 55 Hz frequency, for every axis (EN60068-2-6)
Shock resistance	11 ms (30 G) 6 shock for every axis (EN60068-2-27)
Housing material	black electro-painted aluminium
Lens material	PMMA
Operating temperature	0 ... 50 °C
Storage temperature	-25 ... 70 °C
Weight	300 g

DIMENSIONS

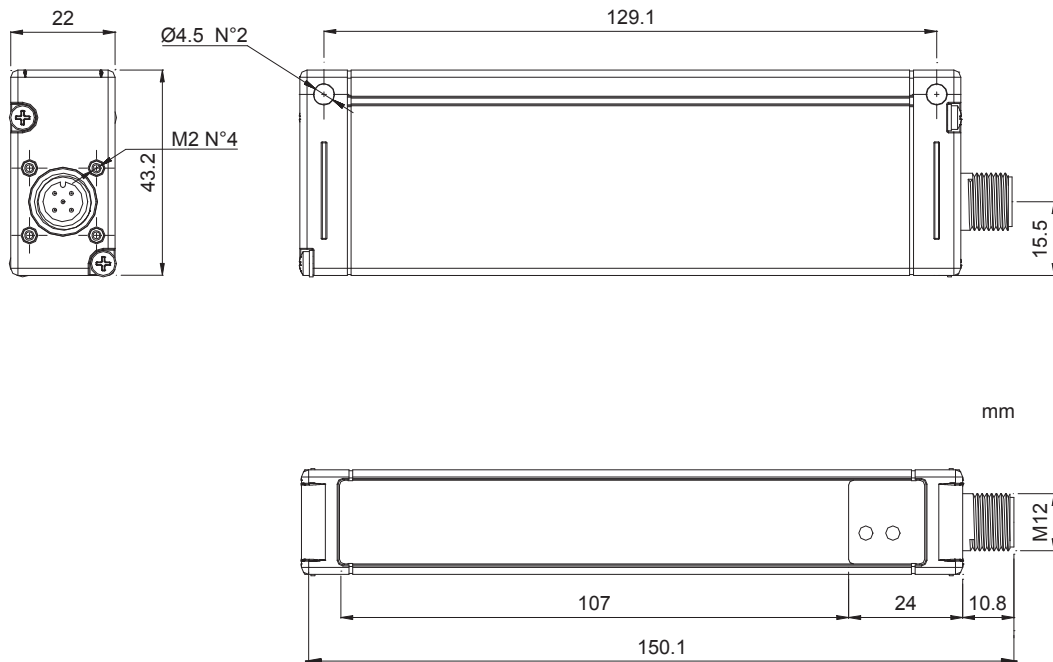

COLOR & CONTRAST SENSORS

INDICATORS AND SETTINGS

Two different models are available: high resolution (AS1-HR) or standard resolution (AS1-SR). In the first case the light array has 16 beams, while in the second case the beams are reduced to 6. In the AS1-HR model, the selection inputs of the SCAN MODE, can configure 4 different crossed-beam scanning modes. These different modes allow to vary the detection performances, in particular the resolution can be increased to 0.2mm thickness, or the response time up to less than 3ms.

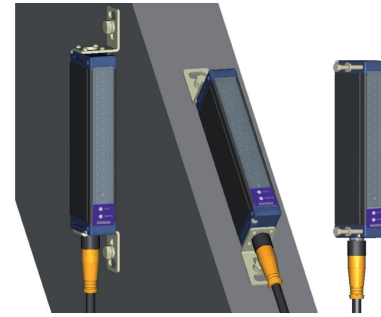

INDICATORS AND SETTINGS (TRIMMER VERSIONS)

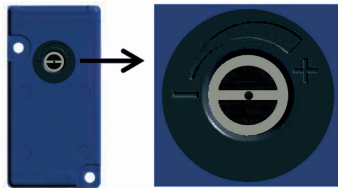

Emitter is equipped with a manual regulation which lets the user change the emission power by means of a screwdriver.

The emission power reduction can be particularly useful to lower passive reflections when maximum operating distance it is not required.

CONNECTIONS

M12 CONNECTOR

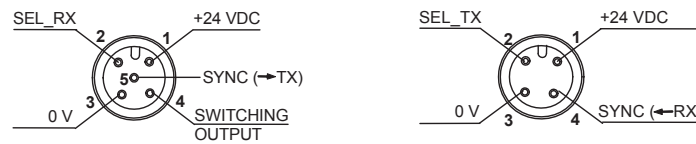

		AS1-HR	AS1-SR			AS1-HR	AS1-SR
RECEIVER (RX): M12 5-pole connector	1 – brown:	+24 VDC	+24 VDC	EMITTER (TX): M12 4-pole connector	1 – brown:	+24 VDC	+24 VDC
	2 – white:	SEL_RX	Not used		2 – white:	SEL_TX	Not used
	3 – blue:	0 V	0 V		3 – blue:	0 V	0 V
	4 – black:	Switching output	Switching output		4 – black:	SYNC **	SYNC *
	5 – grey:	SYNC *	SYNC *				

* not used in trimmer version
** SEL_TX2 in trimmer version

HIGH RESOLUTION SCANNING MODE

PROG. N°	SEL_RX	SEL_TX	RESOLUTION	RESPONSE TIME (msec)
1	0 Vdc or FLOAT	0 Vdc or FLOAT	LOW	2.75
2	0 Vdc or FLOAT	24 Vdc	M/L	3
3	24 Vdc	0Vdc or FLOAT	M/H	7.75
4	24 Vdc	24 Vdc	HIGH	8

Scan mode 1:
high speed / low resolution
Minimum object detection
Flat = 0.4 (thickness) x 100 (width) mm
Cylindrical objects = \varnothing 6 mm

Scan mode 2:
high speed / mid resol. central area
Minimum object detection
Flat = 0.4 (thickness) x 90 (width) mm
Cylindrical objects = \varnothing 6 mm

Scan mode 3-4:
low speed / high resolution
Minimum object detection
Flat = 0.2 (thickness) x 75 (width) mm
Cylindrical objects = \varnothing 6 mm

STANDARD RESOLUTION SCANNING MODE

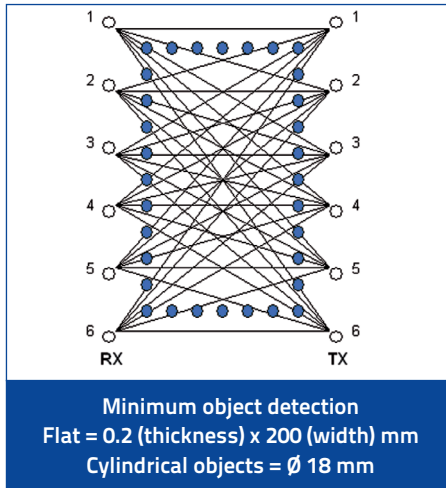

Note: the scan mode is fixed in the standard resolution version.

MODEL SELECTION AND ORDER INFORMATION

OPTIC FUNCTION	OPERATING DISTANCE	RESOLUTION	SETTING	MODEL	ORDER No.
Area sensor	2 m	High	n/a	AS1-LD-HR-010-J	958101000
			Adjustment Trimmer	AS1-LD-HR-010-P	958101040
		Standard	n/a	AS1-LD-SR-010-J	958101010
			Adjustment Trimmer	AS1-LD-SR-010-P	958101050
	3 m	High	n/a	AS1-HD-HR-010-J	958101020
		Standard	n/a	AS1-HD-SR-010-J	958101030

CABLES

TYPE	DESCRIPTION	LENGTH	MODEL	ORDER No.
Axial M12 Connector	4-pole, grey, P.V.C.	3 m	CS-A1-02-G-03	95A251380
		5 m	CS-A1-02-G-05	95A251270
		10 m	CS-A1-02-G-10	95A251390
	4-pole, U.L., black, P.V.C.	3 m	CS-A1-02-U-03	95ASE1120
		5 m	CS-A1-02-U-05	95ASE1130
		10 m	CS-A1-02-U-10	95ASE1140
		15 m	CS-A1-02-U-15	95ASE1150
		25 m	CS-A1-02-U-25	95ASE1160
	5-pole, grey, P.V.C.	3 m	CS-A1-03-G-03	95ACC2110
		5 m	CS-A1-03-G-05	95ACC2120
		10 m	CS-A1-03-G-10	95ACC2140
	5-pole, U.L., black, P.V.C.	3 m	CS-A1-03-U-03	95ASE1170
		5 m	CS-A1-03-U-05	95ASE1180
		10 m	CS-A1-03-U-10	95ASE1190
		15 m	CS-A1-03-U-15	95ASE1200
25 m		CS-A1-03-U-25	95ASE1210	
		50 m	CS-A1-03-U-50	95A252700

DIMENSION LIGHT GRIDS

DS1

AREAscan™ detection and measurement light grids with analog output

- 4 mm resolution and 1 ms response time
- 100 to 300 mm controlled height
- Operating distance up to 4 m
- PNP digital and 0-10 V analog outputs
- Adjustment trimmer

APPLICATIONS

- Processing and Packaging machinery
- Food, Cosmetic, Pharmaceutical
- Electronics and mechanical assembling
- Conveyor lines and sorting systems



DS1		
Light array (controlled height)		100...300 mm
Resolution		4...7 mm
Number of beams		16...48
Light emission		IR LED
Response time		1...2,75 ms
Setting		Trimmer
Operating distance		0,15...0,8 m (SD)
		0,15...2,1 m (LD)
		0,2...4 m (HD)
Power supply	Vdc	24V +/- 15%
	Vac	
	Vac/dc	
Output	PNP	▪
	NPN	
	NPN/PNP	
	relay	
	other	0...10 V Analog output
Connection	cable	
	connector	▪
	pig-tail	
Approximate dimensions (mm)		22x43x(150/350)
Housing material		aluminium
Mechanical protection		IP65

TECHNICAL DATA

Power supply	24 Vdc ± 15%
Consumption on emitter unit (TX)	150 mA max.
Consumption on receiver unit (RX)	50 mA max. load excluded
Light emission	IR LED 880 nm
Setting	adjustment trimmer (mod. DS1...PV)
Indicators	yellow OUTPUT LED green POWER ON LED
Output	PNP; analog output
Output current	100 mA max.
Saturation voltage	1,5 V max.
Response time	1 - 2,75 ms
Connection	M12 4-pole connector (TX), M12 5-pole connector (RX)
Dielectric strength	500 Vac, 1 min between electronics and housing
Insulating resistance	>20 MΩ, 500 Vdc between electronics and housing
Mechanical protection	IP65 (EN 60529)
Vibrations	0,5 mm amplitude, 10 ... 55 Hz frequency, for every axis (EN60068-2-6)
Shock resistance	11 ms (30 G) 6 shock for every axis (EN60068-2-27)
Housing material	black electro-painted aluminium
Lens material	PMMA
Operating temperature	0 ... 50 °C
Storage temperature	-25 ... 70 °C
Weight	300 g (mod. DS1...010)
	400 g (mod. DS1...015)
	600 g (mod. DS1...030)

DIMENSIONS

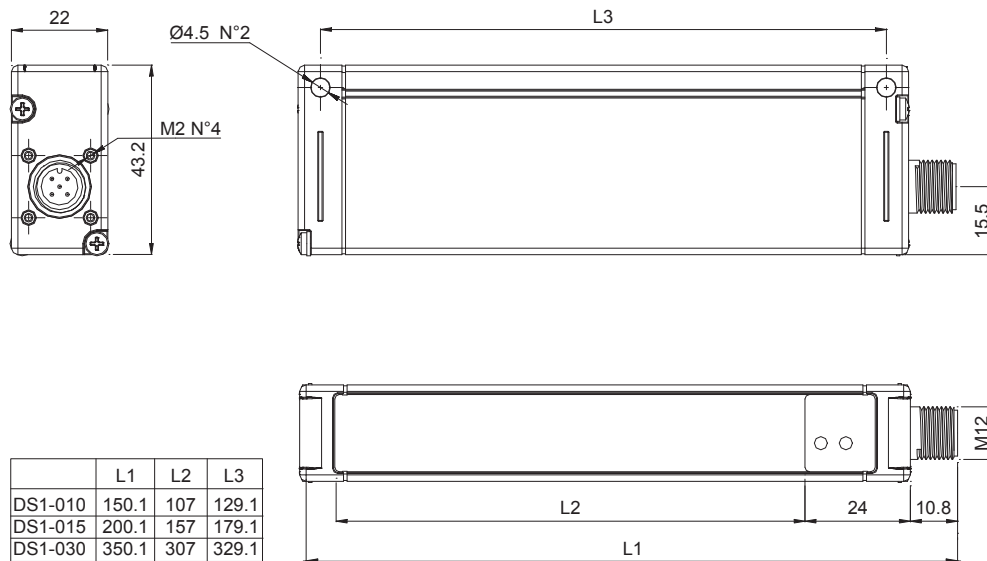

DIMENSION LIGHT GRIDS

INDICATORS AND SETTINGS (TRIMMER VERSIONS)



CONNECTIONS

M12 CONNECTOR

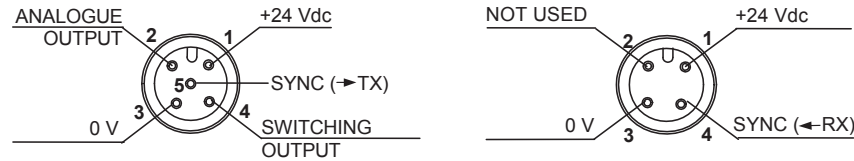

RECEIVER (RX): M12 5-pole connector	1 – brown:	+24 Vdc	EMITTER (TX): M12 4-pole connector	1 – brown:	+24 Vdc
	2 – white:	Analogue output		2 – white:	Not used
	3 – blue:	0 V		3 – blue:	0 V
	4 – black:	Switching output		4 – black:	SYNC
	5 – grey:	SYNC			

DETECTION DIAGRAMS

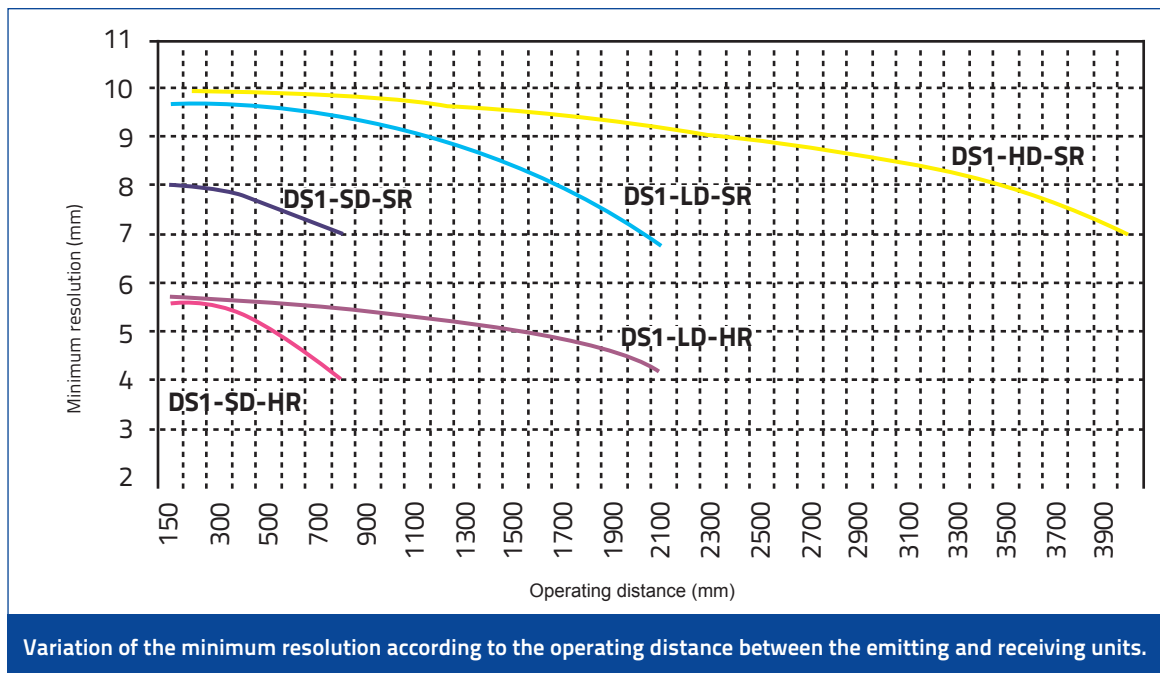

MODEL SELECTION AND ORDER INFORMATION

OPTIC FUNCTION	OPERATING DISTANCE	SETTING	CONTROLLED HEIGHT & RESOLUTION	MODEL	ORDER NO
Measurement light curtain	0,8 m	n/a	100 mm (res.: 7 mm)	DS1-SD-SR-010-JV	957701170
			100 mm (res.: 4 mm)	DS1-SD-HR-010-JV	957701200
			150 mm (res.: 7 mm)	DS1-SD-SR-015-JV	957701180
			150 mm (res.: 4 mm)	DS1-SD-HR-015-JV	957701210
			300 mm (res.: 7 mm)	DS1-SD-SR-030-JV	957701190
	2 m		100 mm (res.: 7 mm)	DS1-LD-SR-010-JV	957701130
			100 mm (res.: 4 mm)	DS1-LD-HR-010-JV	957701120
			150 mm (res.: 7 mm)	DS1-LD-SR-015-JV	957701150
			150 mm (res.: 4 mm)	DS1-LD-HR-015-JV	957701140
			300 mm (res.: 7 mm)	DS1-LD-SR-030-JV	957701160
	4 m	Adjustment trimmer	100 mm (res.: 7 mm)	DS1-LD-SR-010-PV	957701250
			150 mm (res.: 7 mm)	DS1-LD-SR-015-PV	957701260
			300 mm (res.: 7 mm)	DS1-LD-SR-030-PV	957701270
	4 m	n/a	100 mm (res.: 7 mm)	DS1-HD-SR-010-JV	957701220
			150 mm (res.: 7 mm)	DS1-HD-SR-015-JV	957701230
300 mm (res.: 7 mm)			DS1-HD-SR-030-JV	957701240	

CABLES

TYPE	DESCRIPTION	LENGTH	MODEL	ORDER No.
Axial M12 Connector	4-pole, grey, P.V.C.	3 m	CS-A1-02-G-03	95A251380
		5 m	CS-A1-02-G-05	95A251270
		10 m	CS-A1-02-G-10	95A251390
	4-pole, U.L., black, P.V.C.	3 m	CS-A1-02-U-03	95ASE1120
		5 m	CS-A1-02-U-05	95ASE1130
		10 m	CS-A1-02-U-10	95ASE1140
		15 m	CS-A1-02-U-15	95ASE1150
		25 m	CS-A1-02-U-25	95ASE1160
	5-pole, grey, P.V.C.	3 m	CS-A1-03-G-03	95ACC2110
		5 m	CS-A1-03-G-05	95ACC2120
		10 m	CS-A1-03-G-10	95ACC2140
	5-pole, U.L., black, P.V.C.	3 m	CS-A1-03-U-03	95ASE1170
		5 m	CS-A1-03-U-05	95ASE1180
		10 m	CS-A1-03-U-10	95ASE1190
		15 m	CS-A1-03-U-15	95ASE1200
		25 m	CS-A1-03-U-25	95ASE1210
		50 m	CS-A1-03-U-50	95A252700

DIMENSION LIGHT GRIDS

DS2

AREAscan™ detection and measurement light grids with serial or Ethernet interface

- 6 or 25 mm resolution
- Relative measurement precision ± 6 mm or ± 22.5 mm
- 150 - 1650 mm controlled heights
- Operating distance up to 10 m
- PNP and 0-10 V Analog output and RS485 or Ethernet interface



APPLICATIONS

- Processing and Packaging machinery
- Food, Cosmetic, Pharmaceutical
- Electronics and mechanical assembling
- Conveyor lines and sorting systems

DS2		
Light array (controlled height)		150...1650 mm
Resolution		6...25 mm
Number of beams		21...231 (res= 6mm)
		6...66 (res= 25mm)
Light emission		IR LED
Response time		5...90 ms
Interface		serial RS485 or Ethernet
Setting		Dip-switches
		Graphic interface
Operating distance		0,3...5 m (res= 6mm)
		0,3...10 m (res=25mm)
Power supply	Vdc	24V +/- 20%
	Vac	
	Vac/dc	
Output	PNP	▪
	NPN	
	NPN/PNP	
	relay	
	other	0...10 V Analog output
Connection	cable	
	connector	▪
	pig-tail	
Approximate dimensions (mm)		35x40x(256...1726)
Housing material		aluminium
Mechanical protection		IP65

TECHNICAL DATA

Power supply	24 Vdc \pm 20%
Consumption on emitter unit (TX)	250 mA max. load excluded
Light emission	IR LED 880 nm
Output	PNP; analog output
Output current	100 mA
Saturation voltage	1,5 V max.
Connection	M12 4-pole connector (TX), M12 8-pole and M12 4-pole type "D" connector (RX)
Dielectric strength	500 Vac, 1 min between electronics and housing
Insulating resistance	>20 M Ω , 500 Vdc between electronics and housing
Electrical protection	class I
Mechanical protection	IP65 (EN 60529)
Vibrations	0,5 mm amplitude, 10 ... 55 Hz frequency, for every axis (EN60068-2-6)
Shock resistance	11 ms (30 G) 6 shock for every axis (EN60068-2-27)
Housing material	painted aluminium (Pulverit 5121/0085 Black)
Lens material	PMMA
Operating temperature	0 ... 50 °C
Storage temperature	-25...70°C
Weight	1,9 - 4,6 kg

DIMENSIONS

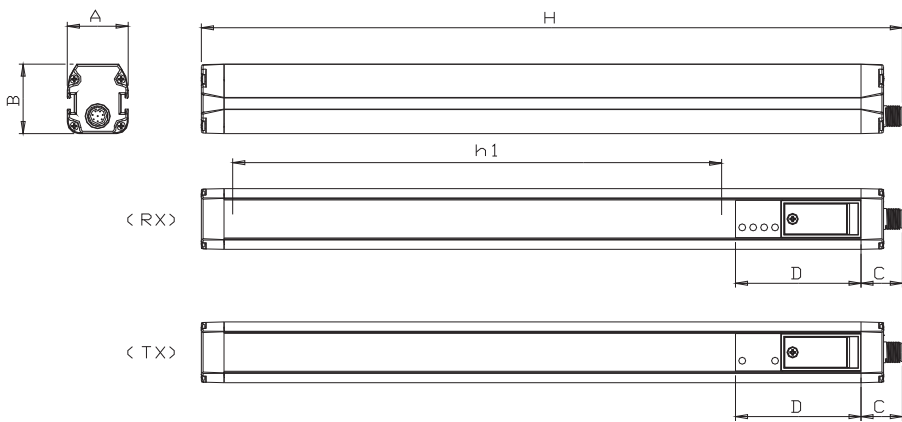

MODEL	A x B (mm)	H (mm)	C (mm)	D (mm)
DS2-05-07-015-XX	35 x 40	256	23.8	72.5
DS2-05-07-030-XX	35 x 40	403	23.8	72.5
DS2-05-07-045-XX	35 x 40	550	23.8	72.5
DS2-05-07-060-XX	35 x 40	697	23.8	72.5
DS2-05-07-075-XX	35 x 40	844	23.8	72.5
DS2-05-07-090-XX	35 x 40	991	23.8	72.5
DS2-05-07-105-XX	35 x 40	1138	23.8	72.5
DS2-05-07-120-XX	35 x 40	1285	23.8	72.5
DS2-05-07-135-XX	35 x 40	1432	23.8	72.5
DS2-05-07-150-XX	35 x 40	1579	23.8	72.5
DS2-05-07-165-XX	35 x 40	1726	23.8	72.5
DS2-05-07-045-XX	35 x 40	562	23.8	72.5
DS2-05-07-060-XX	35 x 40	713	23.8	72.5
DS2-05-07-075-XX	35 x 40	864	23.8	72.5
DS2-05-07-090-XX	35 x 40	1015	23.8	72.5

XX: JV for serial models or JE for ETHERNET models

CONNECTIONS

M12 CONNECTOR - SERIAL VERSION

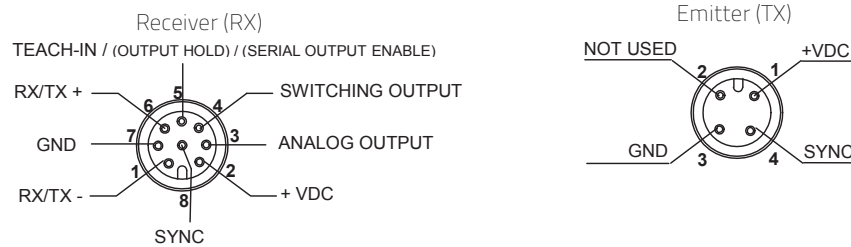

M12 CONNECTOR - ETHERNET VERSION

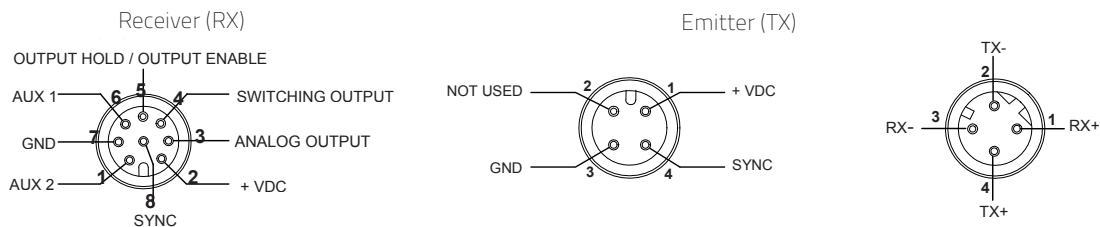

DIMENSION LIGHT GRIDS

INDICATORS AND SETTING



DETECTION MODE EXAMPLES

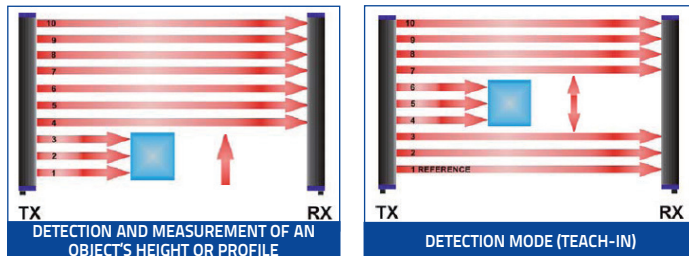

And more applications:

- Object height measurement (vertical mounting);
- Object width measurement (horizontal mounting);
- Object distance measurement (horizontal mounting);
- Object volume measurement (vertical and horizontal combination);
- Single or multiple object presence and/or position detection in a given area;
- Missing label detection on multiple lanes;
- Vertical warehouse drawers positioning;
- Box or other objects profiling on conveyors;
- Web edges or center guiding;
- Cartoners, stackers and palletizers.

RESPONSE TIME - SERIAL AND ETHERNET VERSION

	Tmin (msec)							Tmax (msec)	
	T2	T3	T4	T5	T6	T7			
MODEL RS485	CONFIGURATION								
	Top beam				Complete beams status				
	Binary	Binary	ASCII	ASCII	Binary	Binary	ASCII	ASCII	
	57600 baud	9600 baud	57600 baud	9600 baud	57600 baud	9600 baud	57600 baud	9600 baud	
	DS2-05-07-015-JV	5.5	12.5	5.05	13	5.5	15	6.5	10
	DS2-05-07-030-JV	7	14	7	14.5	7	18	8.5	21
	DS2-05-07-045-JV	8.5	15.5	8.5	16	8.5	21	10	24
	DS2-05-07-060-JV	10	17	10	18	10	26	12	38
	DS2-05-07-075-JV	11.5	18.5	11.5	19	11.5	31	15	44
	DS2-05-07-090-JV	13	20	13	20	13	36	17	54
DS2-05-07-105-JV	14.5	21.5	14.5	22	14.5	40	19	62	
DS2-05-07-120-JV	17	24	17	24	17	44	21	70	
DS2-05-07-135-JV	18.5	25	19	26	19	48	23	80	
DS2-05-07-150-JV	20	26.5	21	28	21	53	25	84	
DS2-05-07-165-JV	22	28	23	30	23	56	28	91	
DS2-05-07-045-JV	5	11	5	11	5	13	6	18	
DS2-05-07-060-JV	5.5	12	5.5	12.5	5.5	14.5	6.5	19.5	
DS2-05-07-075-JV	6	13	6	13.5	6	16	7	21	
DS2-05-07-090-JV	6.5	13.5	6.5	14.5	6.5	17.5	7.5	22.5	
MODEL ETHERNET	CONFIGURATION								
	Top beam				Complete beams status				
	Binary	ASCII		Binary		ASCII			
	10	10		10		12			
	11.5	11.5		11.5		15			
	13	13		13		17			
17	17		17		21				
20	21		21		25				
22	23		23		28				

MODEL SELECTION AND ORDER INFORMATION

OPTIC FUNCTION	CONTROLLED AREA (mm)	OPTICS INTERAXIS (mm)	OUTPUT	MODEL	ORDER No.
Measurement light curtain	147	6.75	Voltage Analog and RS485	DS2-05-07-015-JV	957501040
	294			DS2-05-07-030-JV	957501050
	441			DS2-05-07-045-JV	957501060
	588			DS2-05-07-060-JV	957501000
	735			DS2-05-07-075-JV	957501070
	882			DS2-05-07-090-JV	957501010
	1029			DS2-05-07-105-JV	957501080
	1176			DS2-05-07-120-JV	957501020
	1323			DS2-05-07-135-JV	957501090
	1470			DS2-05-07-150-JV	957501100
	1617	DS2-05-07-165-JV	957501030		
	453	25	Voltage Analog and RS485	DS2-05-25-045-JV	957501110
	604			DS2-05-25-060-JV	957501140
	755			DS2-05-25-075-JV	957501120
	912			DS2-05-25-090-JV	957501130
	588	6.75	Voltage Analog and Ethernet	DS2-05-07-060-JE	957501150
	735			DS2-05-07-075-JE	957501160
	882			DS2-05-07-090-JE	957501170
	1176			DS2-05-07-120-JE	957501180
	1470			DS2-05-07-150-JE	957501190
1617	DS2-05-07-165-JE			957501200	

CABLES

TYPE	DESCRIPTION	LENGTH	MODEL	ORDER No.
Axial M12 Connector	4-pole, grey, P.V.C.	3 m	CS-A1-02-G-03	95A251380
		5 m	CS-A1-02-G-05	95A251270
		10 m	CS-A1-02-G-10	95A251390
	4-pole, P.U.R.	2 m	CS-A1-02-R-02	95A251540
		5 m	CS-A1-02-R-05	95A251560
		10 m	CS-A1-02-R-10	95A251570
	8-pole, black, P.V.C.	3 m	CS-A1-06-B-03	95ACC2230
		5 m	CS-A1-06-B-05	95ACC2240
		10 m	CS-A1-06-B-10	95ACC2250
	4-pole, shielded, grey, P.V.C.	3 m	CV-A1-22-B-03	95ACC1480
		5 m	CV-A1-22-B-05	95ACC1490
		10 m	CV-A1-22-B-10	95ACC1500
	8-pole, shielded, black, P.V.C.	3 m	CV-A1-26-B-03	95ACC1510
		5 m	CV-A1-26-B-05	95ACC1520
		10 m	CV-A1-26-B-10	95ACC1530
		15 m	CV-A1-26-B-15	95ACC2080
		25 m	CV-A1-26-B-25	95ACC2100
	4-pole, U.L., black, P.V.C.	3 m	CS-A1-02-U-03	95ASE1120
		5 m	CS-A1-02-U-05	95ASE1130
		10 m	CS-A1-02-U-10	95ASE1140
		15 m	CS-A1-02-U-15	95ASE1150
		25 m	CS-A1-02-U-25	95ASE1160
	8-pole, U.L., black, P.V.C.	3 m	CS-A1-06-U-03	95ASE1220
		5 m	CS-A1-06-U-05	95ASE1230
		10 m	CS-A1-06-U-10	95ASE1240
		15 m	CS-A1-06-U-15	95ASE1250
		25 m	CS-A1-06-U-25	95ASE1260
50 m	CS-A1-06-U-50	95A252710		
4-pole, black	Connector-not cabled	CS-A1-02-B-NC	G5085002	
8-pole, black	Connector-not cabled	CS-A1-06-B-NC	95ACC2550	

DISTANCE SENSORS

S65-M

Time Of Flight long range background suppressor

- Long Range background suppression detection up to 5m
- Cost effective solution for precise and reliable detection
- Risk-free Infrared LED emission and embedded green LED pointer
- Two independent fully programmable outputs
- NPN/PNP or IO-Link connection models
- Rugged plastic housing in compact 50x50x24 mm format



APPLICATIONS

- Presence of all medium and large sized objects on conveyors
- Critical object detection in front of problematic background
- Positioning tasks in palletizing
- Position limiter for deck and robot in automotive manufacturing
- Collision prevention limit switch for AGV applications
- Checking filling level for liquid and objects



S65-M		
Operating Distance		0.1..5 m (90% white) / 0.1..4 m (18% grey) / 0.1..2.5 m (6 % black)
Hysteresis		20mm / 50mm / 80mm
Difference White 90%/Grey 18% and White 90%/Black 6%		see chart (value Typ, 1, T=25°C, ambient light <1Klux)
Repeatability error		20mm for distance > 750mm / 40mm for distance <= 750mm (1, T=25°C)
Response time		8.5 msec max.T=25°C
Operating Frequency		<65Hz
Setting		Teach-in buttons SET1, SET2
Teach-in Input		Active High (+24V) 1 sec < t < 3 sec teach Q1 / > 3 sec teach Q2
Supply voltage	Vdc	24 VDC ± 20%
	Vac	
	Vac/dc	
Switching output	PNP	
	NPN	
	NPN/PNP	Can be set up (PNP NPN / Light Dark) 100mA max.
	relay	
	other	IO-Link V1.1
Connections	cable	
	connector	M12 - 5 poles
	pig-tail	
Exposed material		Body ABS / Display POLYESTER
Front side material		PMMA
Dimensions		50 x 50 x 25 mm
Mechanical protection		IP67
Weight		50 g.max.
UL (requirements)		Class 2 power supply according to UL 508

TECHNICAL DATA

Supply voltage	24 VDC \pm 20%
Consumption	< 2.2 W (excluding any loads)
Operating Distance	0.1..5 m (90% white) / 0.1..4 m (18% grey) / 0.1..2.5 m (6 % black)
Hysteresis	20mm / 50mm / 80mm
Response time	8.5 msec max.
Difference White 90%/Grey 18% and White 90%/Black 6%	see chart (value Typ, 1, T=25°C, ambient light <1klux)
Repeatability error	20mm for distance > 750mm / 40mm for distance \leq 750mm (1, T=25°C)
Thermal compensation error	1.5 mm / °C (T \neq 25°C)
Switching output	Can be set up (PNP NPN / Light Dark) 100mA max.
Teach-in Input	Active High (+24V) 1 sec < t < 3 sec teach Q1 / > 3 sec teach Q2
Warming-up time	20 min typ
Warnings	Q1 (YELLOW) / Q2 (YELLOW) / ON PWR (GREEN) - PNP / NPN (GREEN)
Operating temperature	-15°...+55 °C (with device ON)
Storage temperature	-25 ...+70 °C
Electrical strength	500 VAC, 1 min between electronics and case
Insulation resistance	> 20 M Ω , 500 VDC between electronics and case
Reading spot size	typ 200x200 mm @ 4m
Pointer spot size (green)	typ 250x250 mm @ 4m
Max. deviation of pointer/reading spot axes origin	+/- 40 mm
Emission and Wavelength	LED / 850 nm
Ambient light rejection	according to EN 60947-5-2,
Vibrations	width 0.5 mm, frequency 10 ... 55Hz, per axis (EN60068-2-6)
Shock resistance	11 ms (30 G) 6 shocks for each axis (EN60068-2-27)
Humidity	< 90% no condensation
Exposed material	Body ABS / Display POLYESTER
Front side material	PMMA
Mechanical protection	IP67
Connections	M12 - 5 poles
(Overall) Dimensions	50 x 50 x 25 mm
Weight	50 g,max.
I/O LINK Connection	NO (See parameter table on www.datalogic.com)
UL (requirements)	Class 2 power supply according to UL 508

DIMENSIONS

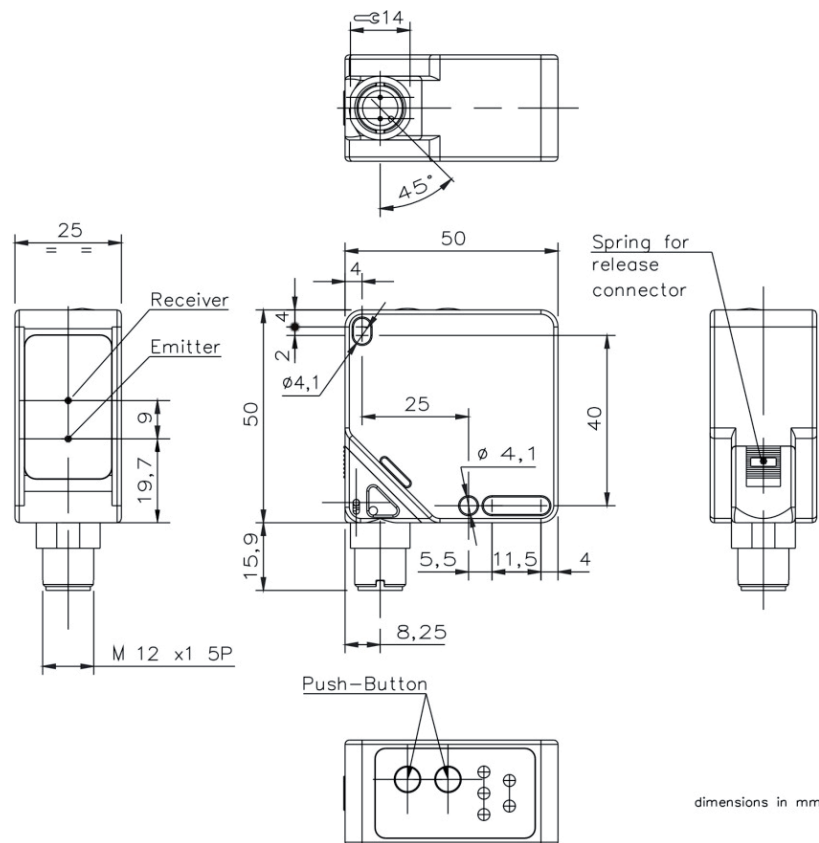

DISTANCE SENSORS

CONNECTIONS

M12 CONNECTOR

S65-PA-5-M13-OO

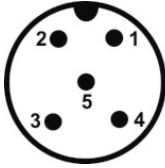

1 (BROWN) : +24 V \pm 20%
 2 (WHITE) : Q2 100mA max.
 3 (BLUE) : 0 V
 4 (BLACK) : Q1 100mA max.
 5 (GREY) : REMOTE TEACH-IN

S65-PA-5-M13-OOZ

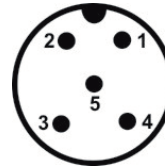

1 (BROWN) : +24 V \pm 20%
 2 (WHITE) : Q2 100mA max.
 3 (BLUE) : 0 V
 4 (BLACK) : C/Q1 (I/O LINK)
 5 (GREY) : REMOTE TEACH-IN

NOTE: Wire colour refers to European standard.

INDICATORS AND SETTINGS

OUTPUT LED (yellow)

Yellow LEDs on, numbered as 1 and 2, indicate activation of Q1 and Q2 outputs. LEDs blink at the same time if measurement is out of range or not available due to the presence of environmental contamination.

POWER LED (green)

Green PWR LED on indicates that the device is switched on and operating.

ACTIVE SETUP LED (green)

Green PNP/NPN LEDs on indicate that the device is in the selected setup.

SET1 Push Button

Teach-in push button for Q1 and setting parameter menu

SET2 Push Button

Teach-in push button for Q2 and setting parameter menu



DETECTION DIAGRAMS

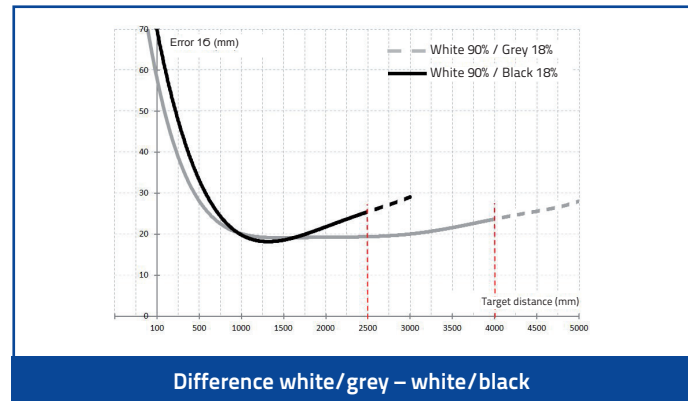
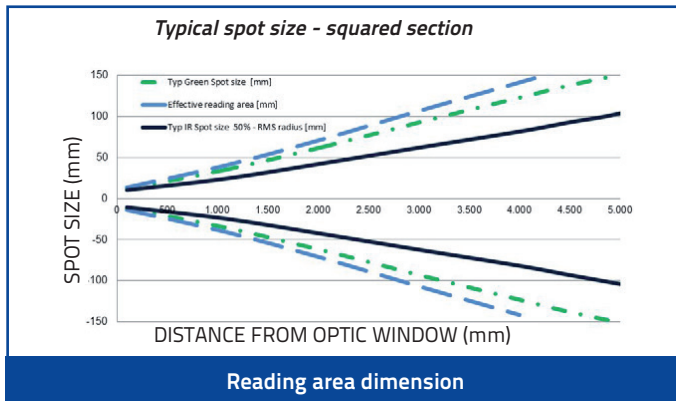

MODEL SELECTION AND ORDER INFORMATION

OPTIC FUNCTION	CONNECTION	OUTPUT	MODEL	ORDER No.
Background Suppression long range IR	M12 5 poles	NPN/PNP	S65-PA-5-M13-00	956251160
	M12 5 poles	IO-LINK	S65-PA-5-M13-00Z	956251170

ACCESSORIES

ST-5020

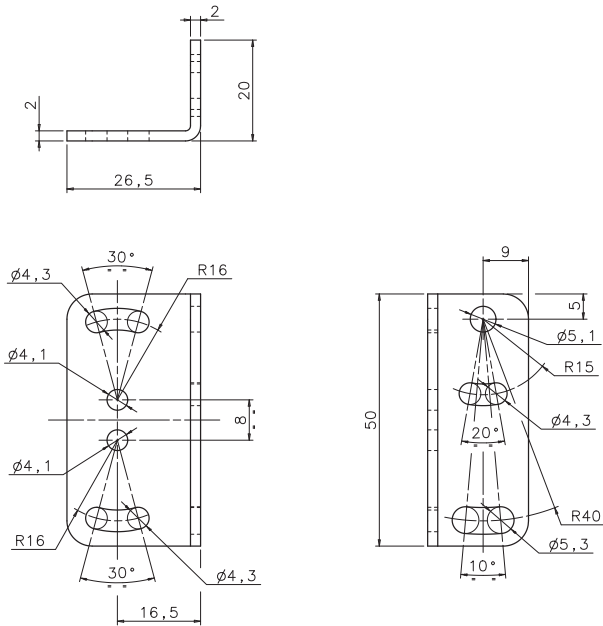

ST-5021

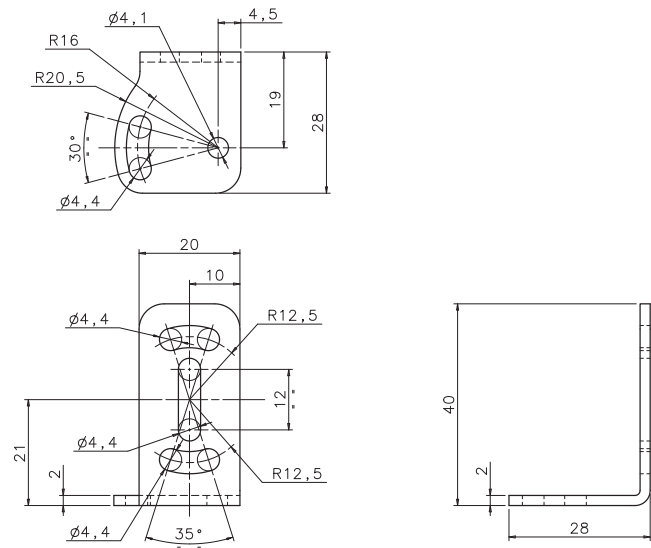

MODEL	DESCRIPTION	ORDER No.
ST-5020	mounting bracket 50 x 27 x 20 mm	95ACC5330
ST-5021	mounting bracket 20 x 40 x 28 mm	95ACC5340

CABLES

TYPE	DESCRIPTION	LENGTH	MODEL	ORDER No.
Axial M12 Connector	M12 5-pole conn. with 3 m unshielded cable	3 m	CS-A1-03-G-03	95ACC2110
	M12 5-pole conn. with 5 m unshielded cable	5 m	CS-A1-03-G-05	95ACC2120
	M12 5-pole conn. with 10 m unshielded cable	10 m	CS-A1-03-G-10	95ACC2140

DISTANCE SENSORS

S80

Time Of Flight measurement LASER distance sensor

- Class 2 visible red LASER emission
- Direct proximity measurement from 4 m to 7 m
- From 20 m to 100m retroreflective models
- High precision and measurement speed
- PNP or NPN, 4-20 mA analog output and RS 485 serial interface

APPLICATIONS

- Automated warehousing
- Trans-elevator and crane positioning
- Automotive assembling lines
- Non-LFT measurement in logistics



S80		
Direct measurement range ¹ :	0,3...4 m (S80-Y0) 0,3...7 m (S80-YL0)	
Retroreflective measurement range ² :	0,3...20,3 m (S80-Y1) 0,3...100,3 m (S80-Y2)	
Repeatability	< 5mm (S80-Y0) 7 mm @7m (S80-YL0) 10 mm @20m (S80-Y1) 10 mm @100m (S80-Y2)	
Switching frequency	100 Hz (Normal), 500 Hz(Fast)	
Light emission	red LASER (class 2)	
Response time	5 ms (Normal), 1 ms(Fast)	
Serial interface	RS485	
Setting	Teach-in	
Power supply	Vdc	15...30 V
	Vac	
Output	Vac/dc	
	PNP	▪
	NPN	▪
	NPN/PNP	
	relay	
Connection	other	4...20 mA Analog output , RS485 serial interface
	cable	
	connector	▪
Connection	pig-tail	
Approximate dimensions (mm)	34x90x73	
Housing material	aluminum	
Mechanical protection	IP67	

¹On target 90% white to 18% grey

²On reflector R80

TECHNICAL DATA

Power supply	15 ... 30 Vdc (limit values)
Ripple	2 V _{pp} max.
Consumption (output current excluded)	130 mA max. (110 mA at 24 V) (mod. S80...Y19/Y29) 170 mA max. (110 mA at 24 V) (mod. S80...Y09/YL09)
Light emission	red Laser 658 nm
Setting	SET push-buttons +/- push-buttons
Indicators	command panel: yellow OUTPUT LED green 4-digit display, 2 OUT1, OUT2 LEDs green FAST LED (mod. S80...Y09/Y19/Y29) indicators LED: yellow OUTPUT LED red ALARM LED
Output	2 PNP or NPN; analog output with 4-20 mA; RS485 serial interface
Output current	100 mA max.
Saturation voltage	2 V max.
Response time	5 ms (norm) and 1 ms (fast) (mod. S80...Y09/Y19/Y29) 6 ms (mod. S80...YL09)
Switching frequency	100 Hz (norm) and 500 Hz (fast) (mod. S80...Y09/Y19/Y29) 85 Hz (mod. S80...YL09)
Connection	M12 8-pole connector
Dielectric strength	500 Vac, 1 min between electronics and housing
Insulating resistance	>20 MΩ, 500 Vdc between electronics and housing
Electrical protection	class 2
Mechanical protection	IP67
Ambient light rejection	according to EN 60947-5-2
Vibrations	0,5 mm amplitude, 10 ... 55 Hz frequency, for every axis (EN60068-2-6)
Shock resistance	11 ms (30 G) 6 shock for every axis (EN60068-2-27)
Housing material	aluminium
Lens material	window and lenses in glass
Operating temperature	-10 ... 50 °C
Storage temperature	-20 ... 70 °C
Weight	330 g max.

DIMENSIONS

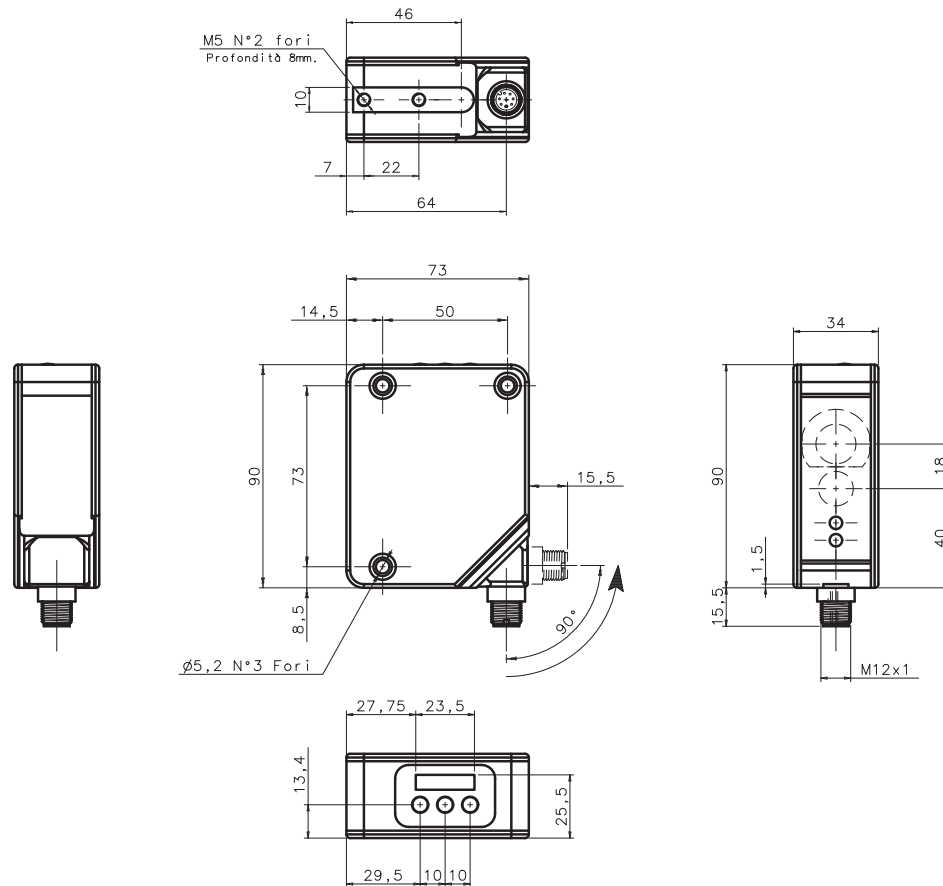

DISTANCE SENSORS

CONNECTIONS

M12 CONNECTOR

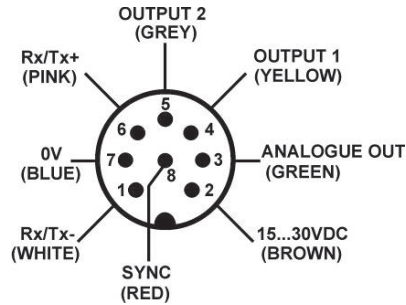

INDICATORS AND SETTINGS

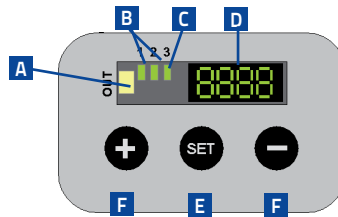
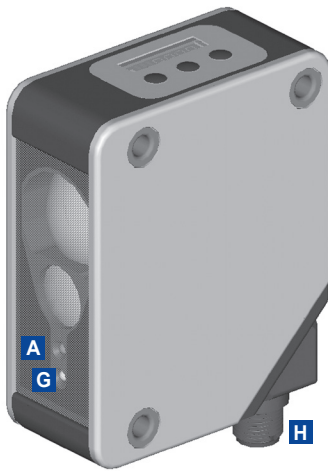

- A** Output 'OR' function LED
- B** Output status LED
- C** Response time LED
- D** 4-digit display
- E** SET push-button
- F** +/- selection push-buttons
- G** Alarm LED
- H** M12 connector output orientable on two positions

DETECTION DIAGRAMS

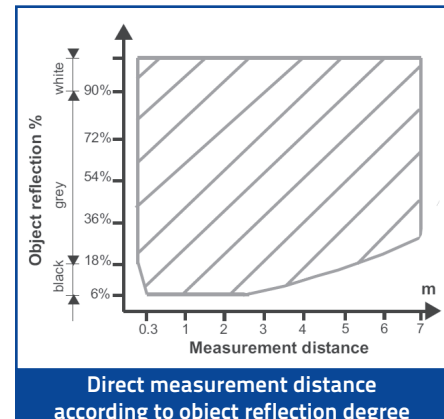
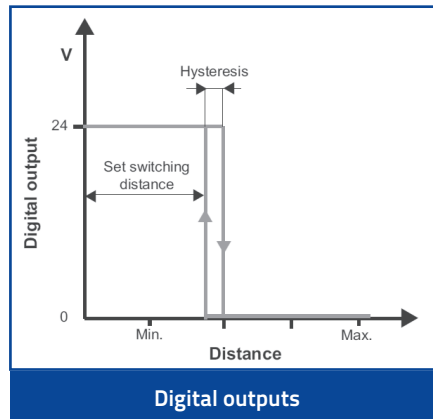
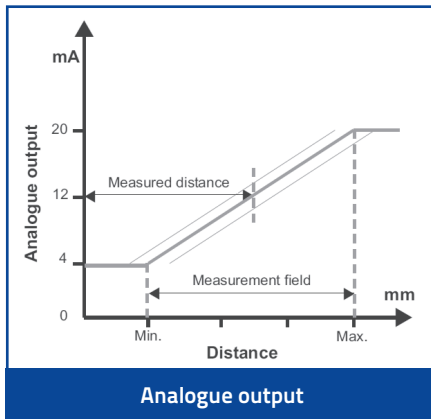

MODEL SELECTION AND ORDER INFORMATION

OPTIC FUNCTION	HOUSING	CONNECTION	OUTPUT	MODEL	ORDER No.
Distance sensor (4 m)	Aluminum	M12 Connector	PNP, Analog 4...20 mA, RS485	S80-MH-5-Y09-PPIZ	951501080
		M12 Connector	NPN, Analog 4...20 mA, RS485	S80-MH-5-Y09-NNIZ	951501010
Distance sensor (7 m)		M12 Connector	PNP, Analog 4...20 mA, RS485	S80-MH-5-YL09-PPIZ	951501060
		M12 Connector	NPN, Analog 4...20 mA, RS485	S80-MH-5-YL09-NNIZ	951501070
Distance sensor (20 m)		M12 Connector	PNP, Analog 4...20 mA, RS485	S80-MH-5-Y19-PPIZ	951501020
		M12 Connector	NPN, Analog 4...20 mA, RS485	S80-MH-5-Y19-NNIZ	951501030
Distance sensor (100 m)		M12 Connector	PNP, Analog 4...20 mA, RS485	S80-MH-5-Y29-PPIZ	951501040
		M12 Connector	NPN, Analog 4...20 mA, RS485	S80-MH-5-Y29-NNIZ	951501050

ACCESSORIES

MODEL	DESCRIPTION	ORDER No.
ST-5037	L-SHAPED mounting bracket	95ACC2260
R80*	S80 distance sensor reflector	95A151210

*Supplied with the sensor

CABLES

TYPE	DESCRIPTION	LENGTH	MODEL	ORDER No.
Axial M12 Connector	8-pole, black, P.V.C.	3 m	CS-A1-06-B-03	95ACC2230
		5 m	CS-A1-06-B-05	95ACC2240
		10 m	CS-A1-06-B-10	95ACC2250
Radial M12 Connector	8-pole, shielded, black, P.V.C.	3 m	CV-A2-26-B-03	95ACC1600
		5 m	CV-A2-26-B-05	95ACC1610
		10 m	CV-A2-26-B-10	95ACC1620
Axial M12 Connector	8-pole, shielded, black, P.V.C.	3 m	CV-A1-26-B-03	95ACC1510
		5 m	CV-A1-26-B-05	95ACC1520
		10 m	CV-A1-26-B-10	95ACC1530
		15 m	CV-A1-26-B-15	95ACC2080
		25 m	CV-A1-26-B-25	95ACC2100
		8-pole, U.L., black, P.V.C.	3 m	CS-A1-06-U-03
	5 m		CS-A1-06-U-05	95ASE1230
	10 m		CS-A1-06-U-10	95ASE1240
	15 m		CS-A1-06-U-15	95ASE1250
	8-pole, black	25 m	CS-A1-06-U-25	95ASE1260
50 m		CS-A1-06-U-50	95A252710	
Connector-not cabled		CS-A1-06-B-NC	95ACC2550	

DISTANCE SENSORS

S81

Cost effective T.O.F. LASER distance sensor

- Class 2 visible red LASER emission
- Plastic housing and optics
- 2 PNP or NPN digital outputs
- 0-10 V analog output or alarm output



APPLICATIONS

- Packaging end of lines
- Carton stacking control
- Paper reel unwinding control
- Automotive assembling line



S81		
Distance sensor		0,3...4 m
Repeatability		± 4 mm
Switching frequency		80 Hz
Light emission		red LASER (class 2)
Response time		5 ms
Setting		push buttons
Power supply	Vdc	24 Vdc +/- 20%
	Vac	
	Vac/dc	
Output	PNP	▪
	NPN	▪
	NPN/PNP	
	relay	
	other	0...10 V Analog output (S81-Y), Alarm output (S81-M)
Connection	cable	
	connector	▪
	pig-tail	
Approximate dimensions (mm)		31x53x80
Housing material		ABS
Mechanical protection		IP67

TECHNICAL DATA

Power supply	24 Vdc \pm 20% (limit values)
Ripple	2 Vpp max.
Consumption (output current excluded)	120 mA max. (100 mA at 24 V)
Light emission	red Laser 665 nm
Setting	OUT1 and OUT2 push-buttons
Indicators	yellow OUTPUT1 and OUTPUT2 LEDs green POWER/READY LED
Output	2 PNP or NPN analog output with 0-10 V (mod. S81-Y), alarm output (S81-M)
Output current	100 mA max.
Response time	5 ms
Switching frequency	80 Hz
Connection	M12 5-pole connector
Dielectric strength	500 Vac, 1 min between electronics and housing
Insulating resistance	20 M Ω , 500 Vdc between electronics and housing
Electrical protection	class 2
Mechanical protection	IP67
Ambient light rejection	according to EN 60947-5-2
Vibrations	0,5 mm amplitude, 10 ... 55 Hz frequency, for every axis (EN60068-2-6)
Shock resistance	11 ms (30 G) 6 shock for every axis (EN60068-2-27)
Housing material	ABS
Lens material	PMMA
Operating temperature	0 ... 50 °C
Storage temperature	-20 ... 70 °C
Weight	92 g max.

DIMENSIONS

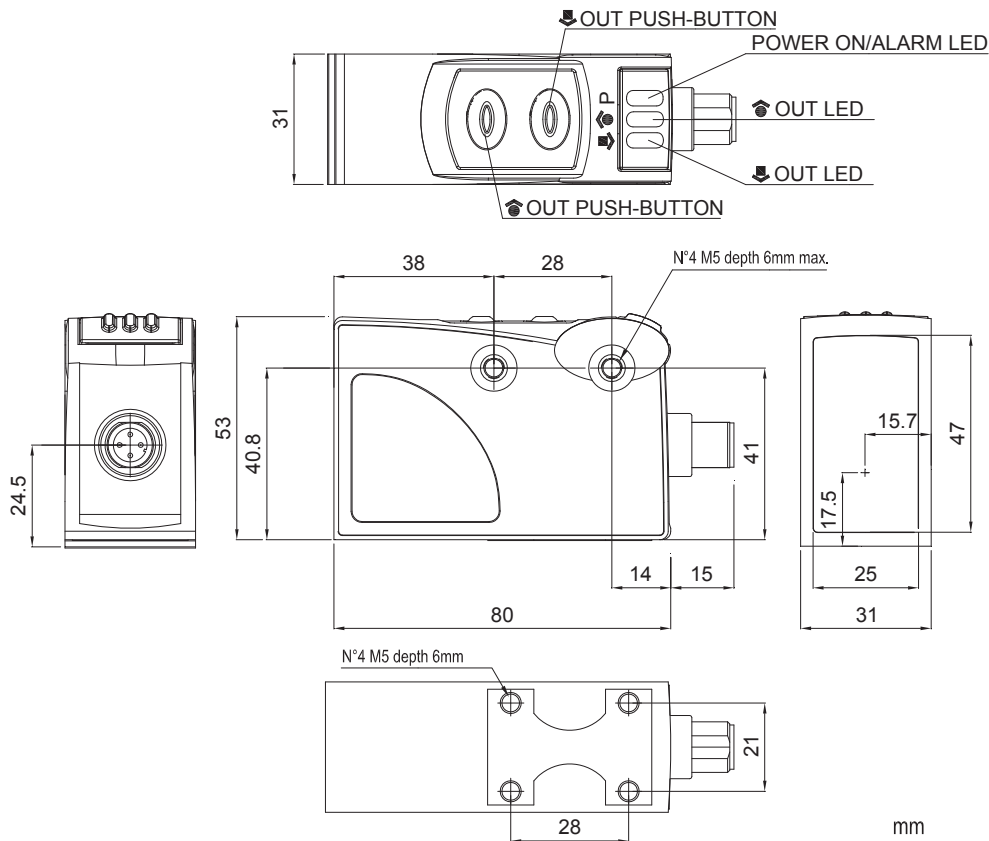

DISTANCE SENSORS

CONNECTIONS

M12 Connector

Background suppression S81-M

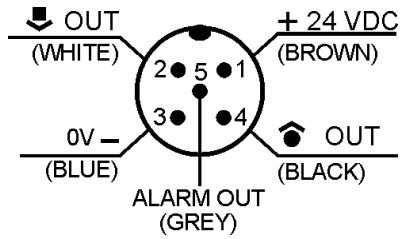

Distance S81-Y

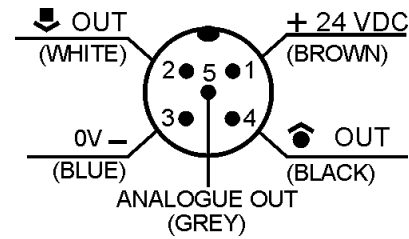

INDICATORS AND SETTINGS

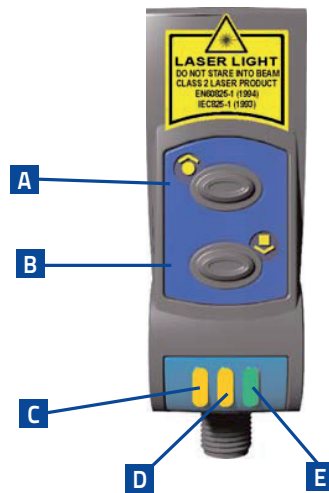

- A Output2 push-button
- B Output1 push-button
- C Output1 LED
- D Output2 LED
- E Power/Alarm LED

DETECTION DIAGRAMS

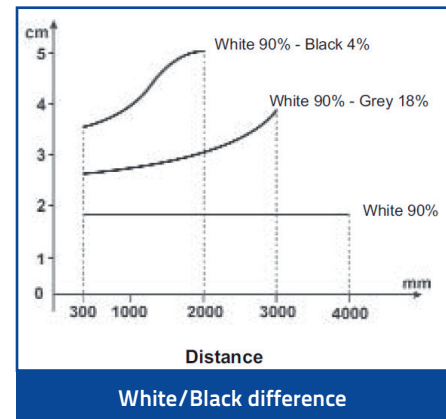
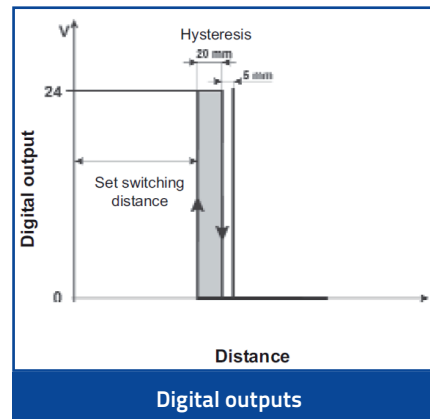
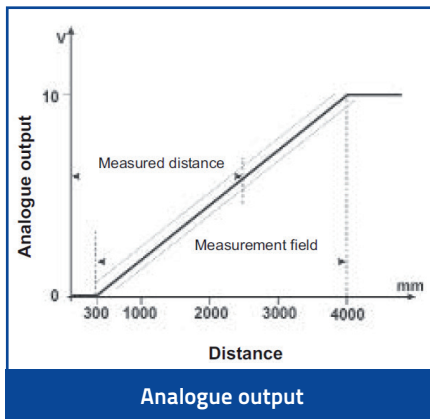

MODEL SELECTION AND ORDER INFORMATION

OPTIC FUNCTION	HOUSING	CONNECTION	OUTPUT	MODEL	ORDER No.
Background suppression	Plastic	M12 Connector	NPN, Alarm	S81-PL-5-M03-NNC	951551000
			PNP, Alarm	S81-PL-5-M03-PPC	951551110
NPN, Analog 0...10V			S81-PL-5-Y03-NNV	951551120	
PNP, Analog 0...10V			S81-PL-5-Y03-PPV	951551030	
PNP, Analog 0...10V, Scalable			S81-PL-5-Y03-PPVK	951551040	
Distance					

ACCESSORIES

ST-S85-STD

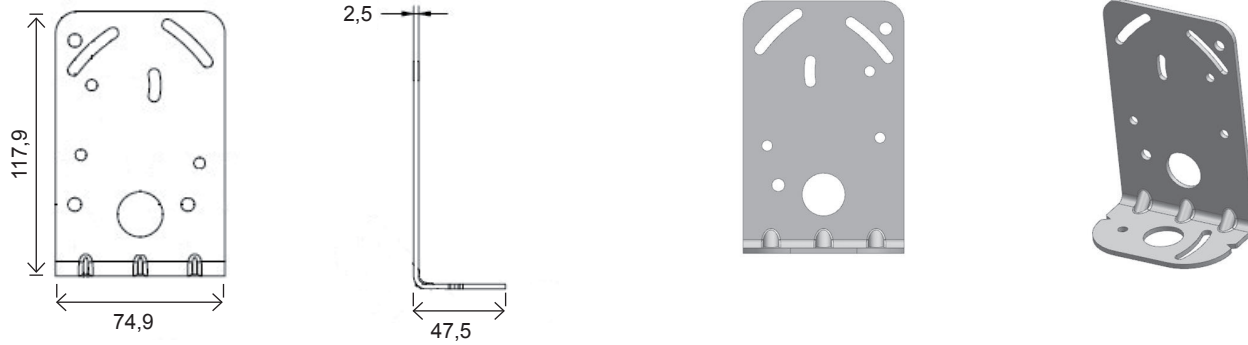

MODEL	DESCRIPTION	ORDER No.
ST-S85-STD	mounting bracket	95ACC7840

CABLES

TYPE	DESCRIPTION	LENGTH	MODEL	ORDER No.
Axial M12 connector	5-pole, grey, P.V.C.	3 m	CS-A1-03-G-03	95ACC2110
		5 m	CS-A1-03-G-05	95ACC2120
		10 m	CS-A1-03-G-10	95ACC2140
	5-pole, U.L., black, P.V.C	3 m	CS-A1-03-U-03	95ASE1170
		5 m	CS-A1-03-U-05	95ASE1180
		10 m	CS-A1-03-U-10	95ASE1190
		15 m	CS-A1-03-U-15	95ASE1200
		25 m	CS-A1-03-U-25	95ASE1210
		50 m	CS-A1-03-U-50	95A252700

DISTANCE SENSORS

S85

LASER distance sensor for precise measurement up to 20 m with a millimeter of resolution and repeatability through the Time of Flight technology

- Time of Flight technology
- Class 2 visible red LASER for an easy alignment with the target
- Measuring range up to 10m or 20m in the advanced model
- 1 mm resolution, 7 mm accuracy, 1 mm repeatability
- 4-20 mA or 0-10 V scalable analog output and 2 digital outputs
- RS485 serial interface in the advanced model
- Standard M12 connector
- IP67 Industrial metal housing



APPLICATIONS

- Automated warehousing
- Processing and Packaging machinery
- Industrial vehicles
- Automotive

S85

Distance sensor (90% White target)		0,2...20 m (S85...Y13) 0,2...10 m (S85...Y03)
Repeatability		1...2 mm
Accuracy		7...10 mm
Resolution		1 mm
Light emission		red LASER (class 2)
Response time		30 ms (S85...Y03) 15...30 ms (S85...Y13)
Serial interface		RS485 (S85...Y13)
Setting		Display (S85...Y13) push-buttons (S85...Y03)
Power supply	Vdc	24 Vdc +/- 20%
	PNP	▪
	NPN	▪
Output	Push pull	▪
	other	Analog output: 4...20 mA or 0...10 V
Connection	connector	▪
Approximate dimensions (mm)		60x72x37
Housing material		Zamak
Mechanical protection		IP67

TECHNICAL DATA

Power supply	24 Vdc ± 20%
Consumption (output current excluded)	2,8 W max. (mod. S85...Y03) 3 W max. (mod. S85...Y13)
Light emission	red Laser 658 nm
Setting	push-buttons (mod. S85...Y03) push-buttons and display (mod. S85...Y13)
Operating distance	90% white target 0,2...10 m (mod. S85...Y03), 0,2...20 m (mod. S85...Y13) 18% grey target 0,2...5 m (mod. S85...Y03), 0,2...8 m (mod. S85...Y13) 6% black target 0,2...3 m (mod. S85...Y03), 0,2...5 m (mod. S85...Y13)
Indicators	yellow Q1 LED, Q2 LED green/red POWER/OUT OF RANGE LED 5-digit multi display (mod. S85...Y13)
Output	push pull/Q (mod. S85...Y03) PNP, NPN, push pull, Q, Qneg (mod. S85...Y13)
Analog output	0-10 V (mod. S85...Y03-00V) 4-20 mA (mod. S85...Y03-00I) 0-10 V/4-20 mA (mod. S85...Y13-00IVY)
Response time	slow 45 ms (mod. S85...Y13) medium 30 ms fast 15 ms (mod. S85...13)
Connection	M12 5-pole connector (mod. S85...Y03), M12 8-pole connector (mod. S85...Y13)
Dielectric strength	500 Vac, 1 min between electronics and housing
Insulating resistance	>20 MΩ, 500 Vdc between electronics and housing
Mechanical protection	IP67
Ambient light rejection	according to EN 60947-5-2, >40 Klux DC ambient light
Vibrations	0,5 mm amplitude, 10 ... 55 Hz frequency, for every axis (EN60068-2-6)
Shock resistance	11 ms (30 G) 6 shock for every axis (EN60068-2-27)
Housing material	ZINC ALLOY ZAMA 13 EN-1774/PC LEXAN 121R display
Lens material	PMMA
Operating temperature	-15 ... 50 °C
Storage temperature	-25 ... 70 °C
Weight	250 g max.

DIMENSIONS

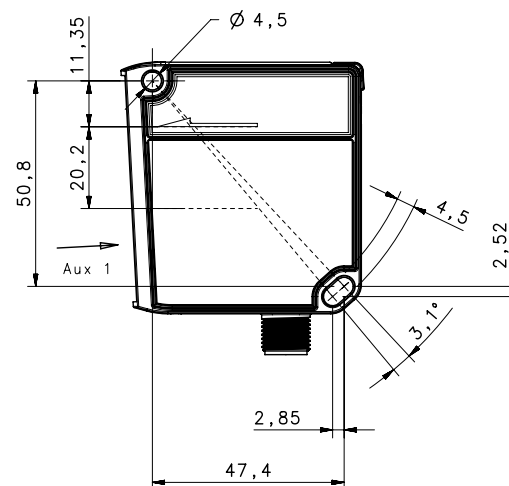
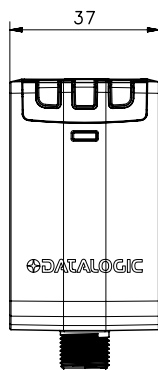
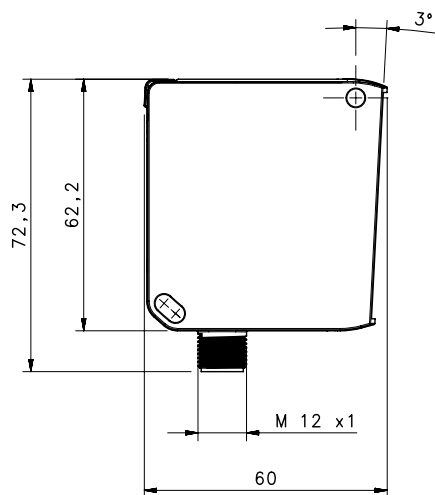

DISTANCE SENSORS

CONNECTIONS

M12 CONNECTOR - STANDARD

S85-Y03-00V
Voltage version

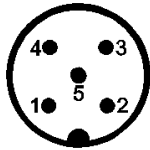

- 1 (BROWN): +24 V \pm 20 %
- 2 (WHITE): Q2 100mA max.
- 3 (BLUE): 0 V
- 4 (BLACK): Q1 100mA max.
- 5 (GREY): ANALOG. OUT 0-10V

S85-Y03-00I
Current version

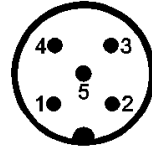

- 1 (BROWN): +24 V \pm 20 %
- 2 (WHITE): Q2 100mA max.
- 3 (BLUE): 0 V
- 4 (BLACK): Q1 100mA max.
- 5 (GREY): ANALOG. OUT 4-20mA

M12 CONNECTOR - ADVANCED

S85-Y13-00IVY
Analog version

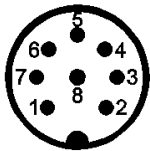

- 1 (WHITE): RS485 -
- 2 (BROWN): +24 V \pm 20 %
- 3 (GREEN): ANALOGUE OUT
- 4 (YELLOW): Q1 100mA max.
- 5 (GREY): Q2 100mA max.
- 6 (PINK): RS485 +
- 7 (BLUE): 0 V
- 8 (RED): MULTIFUNC.INPUT

S85-Y13-00Y

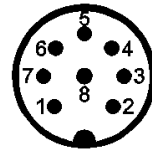

- 1 (WHITE): RS485 -
- 2 (BROWN): +24 V \pm 20 %
- 3 (GREEN): RESERVED
- 4 (YELLOW): Q1 100mA max.
- 5 (GREY): Q2 100mA max.
- 6 (PINK): RS485 +
- 7 (BLUE): 0 V
- 8 (RED): MULTIFUNC.INPUT

INDICATORS AND SETTINGS

Without the procedure setting the sensor is configured to measure distances on a white target from a minimum value of 200 mm and a maximum of 20000 mm, with both switching point placed at 500 mm.

The parameters can be changed by the menu on the display pointing the LASER on the target in the different interested points.



INDICATORS

- LED 1 | Q1 (yellow)
- LED 2 | Q2 (yellow)
- LED 3 | POWER ON (green),
OUT OF RANGE (red)

DISPLAY

- Run/W.UP → Run mode or Warm-up mode
- Q+Q → Digital Output setting → PNP/NPN/Push-Pull
- I/V → Analog Output Setting → Ampere/Volt
- Lock Symbol → Keylock or unlock
- 5-digit display → Value corresponds to Distance in mm

Menu	Functions
OUT 1	Switching point1: Light/ Dark; Switching point value; PNP, NPN, Push-pull; Alarm
OUT 2	Switching point 2: Light/ Dark; Switching point value; PNP, NPN, Push-pull; Alarm
HYSTERESIS	Hysteresis level: 5...1000 mm
ANALOG OUT	Voltage (0...10 V); Current (4...20 mA)
MULTIFUNCTION IN	LASER OFF; Teach IN (Thresholds); RS485 Send Data
AVERAGE	Response time: SLOW; MEDIUM; FAST
RS485	Node N°; Enable; Termination; Output mode; Delay (0...254 ms)
SCALABLE OUT	Analog output range: Reset, MIN and MAX distance
FACTORY RESET	Factory default values
INFO	Software version

DETECTION DIAGRAMS

CURRENT ANALOG OUTPUT
 MEASUREMENT RANGE (4...20 mA)
 OUT OF RANGE (3,95...4 mA; 20...20,5 mA)

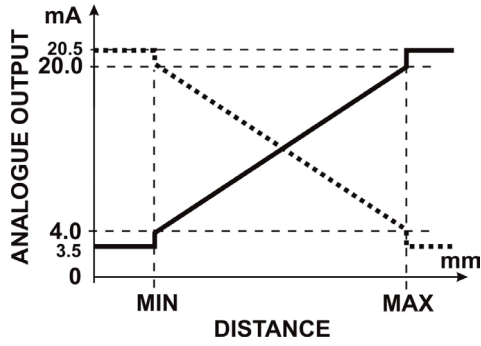

VOLTAGE ANALOG OUTPUT
 MEASUREMENT RANGE (0...10 V)

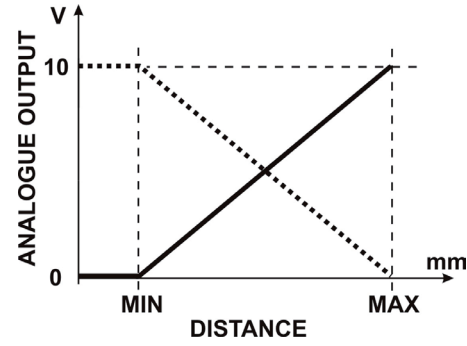

S85-...-Y13 ADVANCED
 REPEATABILITY (SLOW MODE)
 [WHITE 90%; GREY 18%; BLACK 6%]

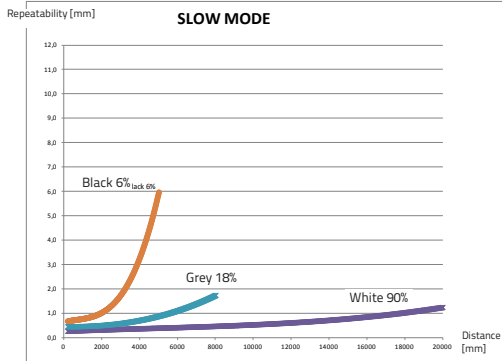

S85-...-Y13 ADVANCED
 REPEATABILITY (MEDIUM MODE)
 [WHITE 90%; GREY 18%; BLACK 6%]

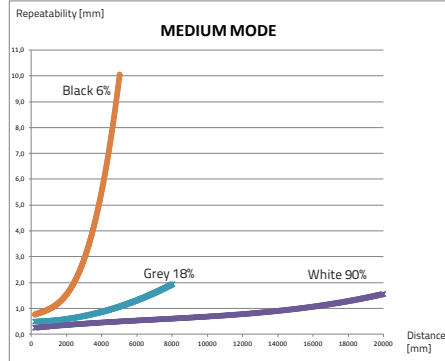

S85-...-Y13 ADVANCED
 REPEATABILITY (FAST MODE)
 [WHITE 90%; GREY 18%; BLACK 6%]

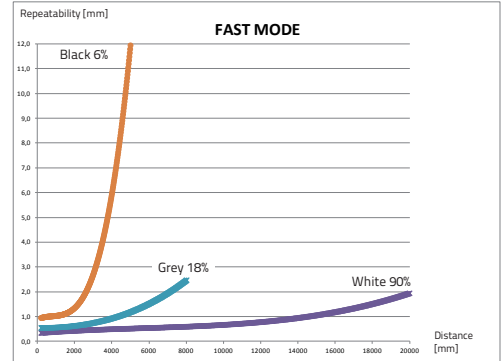

S85-...-Y13 ADVANCED
 REPEATABILITY/RESPONSE TIME
 (90% WHITE TARGET @ 20 m)

Mode	Response time	Repeatability
Slow	45 ms	< 1,5 mm
Medium	30 ms	1,5 mm
Fast	15 ms	< 2 mm

HYSTERESIS

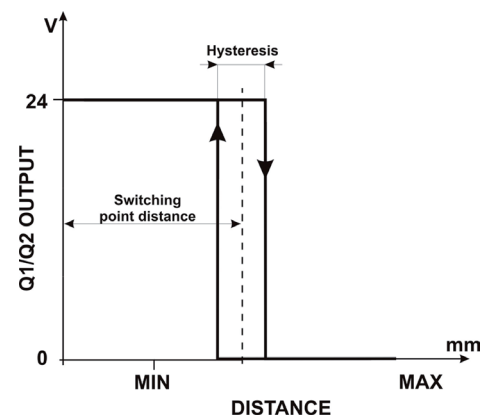

DISTANCE SENSORS

MODEL SELECTION AND ORDER INFORMATION

OPTIC FUNCTION	OPERATING DISTANCE	CONNECTION	OUTPUT & INPUT	MODELS	ORDER No.
Distance sensor (Standard)	10 m	M12 5-pole connector	2 Digital outputs; Analog output: Voltage (0...10 V)	S85-MH-5-Y03-OOV	951511010
			2 Digital outputs; Analog output: Current (4... 20mA)	S85-MH-5-Y03-OOI	951511030
Distance sensor (Advanced)	20 m	M12 8-pole connector	2 Digital outputs; Analog output: Current (4... 20mA) or Voltage (0...10 V); RS485; Multifunction input	S85-MH-5-Y13-OOIVY	951511020
			2 Digital outputs; RS485; Multifunction input	S85-MH-5-Y13-OOY	951511040

ACCESSORIES

ST-S85-STD

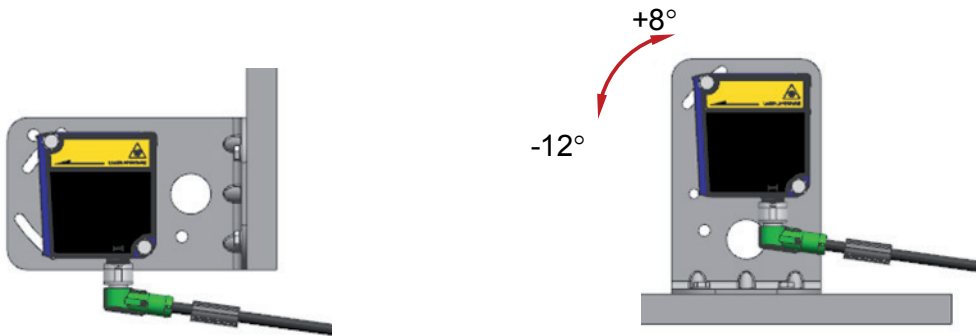
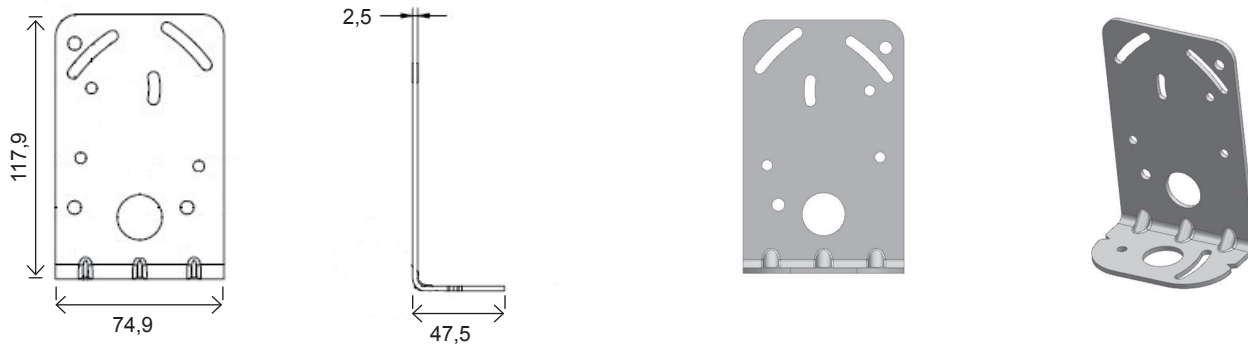

MODEL	DESCRIPTION	ORDER No.
ST-S85-STD	mounting bracket	95ACC7840

CABLES

TYPE	DESCRIPTION	LENGTH	MODEL	ORDER No.
Axial M12 connector	5-pole, grey, P.V.C.	3 m	CS-A1-03-G-03	95ACC2110
		5 m	CS-A1-03-G-05	95ACC2120
		10 m	CS-A1-03-G-10	95ACC2140
	5-pole, U.L., black, P.V.C	3 m	CS-A1-03-U-03	95ASE1170
		5 m	CS-A1-03-U-05	95ASE1180
		10 m	CS-A1-03-U-10	95ASE1190
		15 m	CS-A1-03-U-15	95ASE1200
		25 m	CS-A1-03-U-25	95ASE1210
		50 m	CS-A1-03-U-50	95A252700
Axial M12 Connector	8-pole, black, P.V.C.	3 m	CS-A1-06-B-03	95ACC2230
		5 m	CS-A1-06-B-05	95ACC2240
		10 m	CS-A1-06-B-10	95ACC2250
Radial M12 Connector	8-pole, shielded, black, P.V.C.	3 m	CV-A2-26-B-03	95ACC1600
		5 m	CV-A2-26-B-05	95ACC1610
		10 m	CV-A2-26-B-10	95ACC1620
Axial M12 Connector	8-pole, shielded, black, P.V.C.	3 m	CV-A1-26-B-03	95ACC1510
		5 m	CV-A1-26-B-05	95ACC1520
		10 m	CV-A1-26-B-10	95ACC1530
		15 m	CV-A1-26-B-15	95ACC2080
		25 m	CV-A1-26-B-25	95ACC2100
		50 m	CV-A1-26-B-50	95A252710
	8-pole, U.L., black, P.V.C.	3 m	CS-A1-06-U-03	95ASE1220
		5 m	CS-A1-06-U-05	95ASE1230
		10 m	CS-A1-06-U-10	95ASE1240
		15 m	CS-A1-06-U-15	95ASE1250
		25 m	CS-A1-06-U-25	95ASE1260
8-pole, black	Connector-not cabled	CS-A1-06-B-NC	95ACC2550	

CS series – Cables & Connectors

The right connection for your photoelectric sensors

- M8 and M12, axial or radial female connectors
- Standard length cables: 3, 5, 7, 10, 15 or 25 m
- 3, 4, 5 or 8 poles
- Shielded or unshielded models
- P.U.R. coated models for use in harsh environments
- P.V.C. coated models for standard use
- Standard M12 4 pole non-cabled connectors

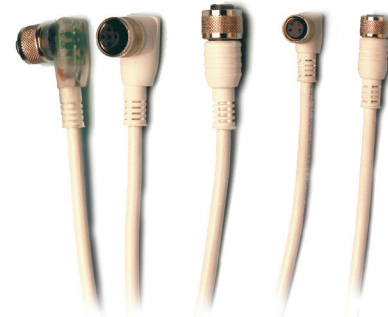

CS	
Connectors	M8 axial or radial(90°) 3 poles M12 axial or radial(90°) 3 poles M8 axial or radial(90°) 4 poles M12 axial or radial(90°) 4 poles M12 axial 5 poles M12 axial 8 poles
Cable lengths	3, 5, 7, 10, 15, 25 m
Conductor diameter	42 x 0.10 mm - 0.35 mm≈ (m12 3-pole) 32 x 0.10 mm - 0.25 mm≈ (m12 4-pole) 32 x 0.10 mm - 0.25 mm≈ (m8 4-pole)
Conductor material	annealed non-tinned electrolytic copper
Flammability class	CEI 20-22, IEC 332/3
Housing material	flame-retardant and non-propagate
Mechanical protection	P.U.R., P.V.C. IP67, with locked ring

CONNECTOR & DIRECTION	POLES	STYLE	CABLE LENGTH	MODEL	ORDER No.	
M12 Connector (Axial)	3-pole	Grey, P.V.C.	3 m	CS-A1-01-G-03	95A251290	
			5 m	CS-A1-01-G-05	95A251300	
			7 m	CS-A1-01-G-07	95A251320	
			10 m	CS-A1-01-G-10	95A251340	
	4-pole	Grey, P.V.C.	3 m	CS-A1-02-G-03	95A251380	
			5 m	CS-A1-02-G-05	95A251270	
			7 m	CS-A1-02-G-07	95A251280	
		P.U.R.	10 m	CS-A1-02-G-10	95A251390	
			2 m	CS-A1-02-R-02	95A251540	
			5 m	CS-A1-02-R-05	95A251560	
	5-pole	Grey, P.V.C.	3 m	CS-A1-03-G-03	95ACC2110	
			5 m	CS-A1-03-G-05	95ACC2120	
			10 m	CS-A1-03-G-10	95ACC2140	
			8-pole	Black, P.V.C.	3 m	CS-A1-06-B-03
	5 m	CS-A1-06-B-05			95ACC2240	
	10 m	CS-A1-06-B-10			95ACC2250	
M12 Connector (Radial 90°)	3-pole	Grey, P.V.C.	3 m	CS-A2-01-G-03	95A251200	
			5 m	CS-A2-01-G-05	95A251210	
			7 m	CS-A2-01-G-07	95A251220	
			10 m	CS-A2-01-G-10	95A251230	
		OIL resistant (CEI 2034-01)	3 m	CS-A2-01-O-03	95A251660	
			5 m	CS-A2-01-O-05	95A251670	
			10 m	CS-A2-01-O-10	95A251680	
			4-pole	Grey, P.V.C.	3 m	CS-A2-02-G-03
	5 m	CS-A2-02-G-05			95A251240	
	7 m	CS-A2-02-G-07			95A251245	
	10 m	CS-A2-02-G-10			95A251260	
	P.U.R.	2 m		CS-A2-02-R-02	95A251550	
		5 m		CS-A2-02-R-05	95A251570	
		OIL resistant (CEI 2034-01)		5 m	CS-A2-02-O-05	95A251690
				10 m	CS-A2-02-O-10	95A251700



M12 Connector with LED (for PNP N.O. sensors) (Radial 90°)	3-pole	Grey, P.V.C.	5 m	CS-A2-11-G-05	95A251310	
			10 m	CS-A2-11-G-10	95A251330	
	4-pole	Grey, P.V.C.	3 m	CS-A2-12-G-03	95A251400	
			5 m	CS-A2-12-G-05	95A251350	
M8 Connector (Axial)	3-pole	Grey, P.V.C.	3 m	CS-B1-01-G-03	95A251490	
			5 m	CS-B1-01-G-05	95A251510	
		P.U.R.	2 m	CS-B1-01-R-02	95A251580	
			5 m	CS-B1-01-R-05	95A251600	
	4-pole	Grey, P.V.C.	3 m	CS-B1-02-G-03	95A251420	
			5 m	CS-B1-02-G-05	95A251430	
		P.U.R.	7 m	CS-B1-02-G-07	95A251440	
			10 m	CS-B1-02-G-10	95A251480	
		OIL resistant (CEI 2034-01)	2 m	CS-B1-02-R-02	95A251620	
			5 m	CS-B1-02-R-05	95A251640	
	M8 Connector (Radial 90°)	3-pole	Grey, P.V.C.	3 m	CS-B2-01-G-03	95A251500
				5 m	CS-B2-01-G-05	95A251520
			P.U.R.	2 m	CS-B2-01-R-02	95A251590
				5 m	CS-B2-01-R-05	95A251610
4 pole		Grey, PVC	3 m	CS-B2-02-G-03	95A251450	
			5 m	CS-B2-02-G-05	95A251460	
		P.U.R.	7 m	CS-B2-02-G-07	95A251470	
			10 m	CS-B2-02-G-10	95A251530	
		OIL resistant (CEI 2034-01)	2 m	CS-B2-02-R-02	95A251630	
			5 m	CS-B2-02-R-05	95A251650	
Shielded M12 Connector (Axial)		3-pole	Grey, P.V.C.	10 m	CV-A1-21-G-10	95ACC2060
				3 m	CV-A1-22-B-03	95ACC1480
		4-pole	Black, P.V.C.	5 m	CV-A1-22-B-05	95ACC1490
				10 m	CV-A1-22-B-10	95ACC1500
	15 m			CV-A1-22-B-15	95ACC2070	
	25 m			CV-A1-22-B-25	95ACC2090	
	8-pole	Black, P.V.C.	3 m	CV-A1-26-B-03	95ACC1510	
			5 m	CV-A1-26-B-05	95ACC1520	
			10 m	CV-A1-26-B-10	95ACC1530	
			15 m	CV-A1-26-B-15	95ACC2080	
			25 m	CV-A1-26-B-25	95ACC2100	
			3 m	CV-A2-22-B-03	95ACC1540	
	Shielded M12 Connector (Radial 90°)	4-pole	Black, P.V.C.	5 m	CV-A2-22-B-05	95ACC1550
				10 m	CV-A2-22-B-10	95ACC1560
8-pole		Black, P.V.C.	3 m	CV-A2-26-B-03	95ACC1600	
			5 m	CV-A2-26-B-05	95ACC1610	
M12 Connector (Axial)	4-pole	U.L., Black, P.V.C.	10 m	CS-A1-02-U-10	95ASE1140	
			15 m	CS-A1-02-U-15	95ASE1150	
			25 m	CS-A1-02-U-25	95ASE1160	
			3 m	CS-A1-03-U-03	95ASE1170	
			5 m	CS-A1-03-U-05	95ASE1180	
	5-pole	U.L., Black, P.V.C.	10 m	CS-A1-03-U-10	95ASE1190	
			15 m	CS-A1-03-U-15	95ASE1200	
			25 m	CS-A1-03-U-25	95ASE1210	
			50 m	CS-A1-03-U-50	95A252700	
			3 m	CS-A1-06-U-03	95ASE1220	
	8-pole	U.L., Black, P.V.C.	5 m	CS-A1-06-U-05	95ASE1230	
			10 m	CS-A1-06-U-10	95ASE1240	
			15 m	CS-A1-06-U-15	95ASE1250	
			25 m	CS-A1-06-U-25	95ASE1260	
50 m			CS-A1-06-U-50	95A252710		
M12 Connector (Axial)	4-pole	Black	Connector- not cabled	CS-A1-02-B-NC	G5085002	
M12 Connector (Radial 90°)	8-pole	Black	Connector- not cabled	CS-A1-06-B-NC	95ACC2550	
	4-pole	Black	Connector- not cabled	CS-A2-02-B-NC	G5085003	

R series – REFLECTORS

Excellent performance with infrared, red light and polarized emission

- Prismatic reflectors for retroreflective sensors
- High efficiency models for long operating distances
- Microprism reflectors for sensors with LASER emission
- Self-adhesive reflectors and reflector tape

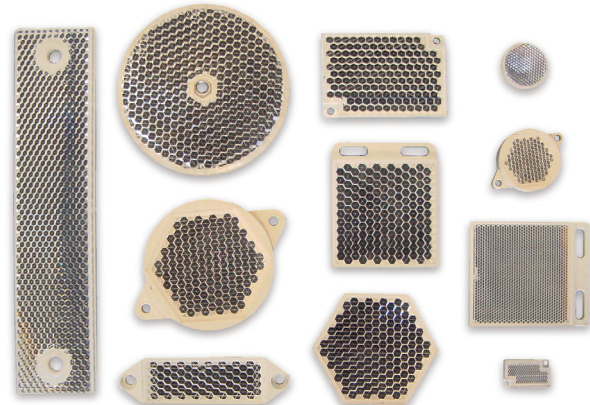

REFLECTORS	
Prismatic reflector material	Reflector in PMMA plastic
Support material	Support in ABS
Mechanical protection	IP67, IP69K (R4K)
Operating temperature	-30 ... +70 °c

MODELS	DESCRIPTION	ORDER No.
R1	Ø 23 mm with Ø 31 mm support	S940700023
R2	Ø 48 mm with Ø 63 mm support	S940700048
R3	18 x 54 mm with 22 x 82 mm support	S940700972
R4	47x 47 mm with 51.5 x 61 mm support	95A151340
R4K	51X61 mm IP69K protection	95A151220
R5	Ø 75 mm with Ø 82 mm support	S940700075
R6	36 x 55 mm with 40.5 x 60 mm support	95A151350
R7	47x47 mm microprism reflector with 51 x 61 mm support	95A151360
R8	9.7 x 19 mm microprism reflector with 13.8 x 23 mm support	95A151370
R9	Ø 23 mm with Ø 25 mm self-adhesive support	95A151080
R10	36 x 176 mm with 41 x 181 mm support	S19120000
R11	146 x 15 mm with 150 x 18 mm support	95A155050
R14	Ø 24 mm with Ø 25 mm support	95A151310
R16	9.7 x 19 mm reflector with 14 x 23 mm support	95A151330
R20	Ø 48 mm microprism reflector with Ø 63 mm support	95A151090
R35	Ø 33 mm with Ø 35 mm support	95A151530
S12	Ø 48 mm with ch.52 mm hexagon support	S940710048
RT3870	200 x 300 mm self-adhesive reflective tape	S940000600
RT3970	200 x 300 mm self-adhesive reflective tape for polarized light	S940000900
RT3970	60 x 40 mm self-adhesive reflective tape for polarized light	S940000604

DIMENSIONS

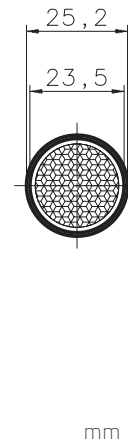
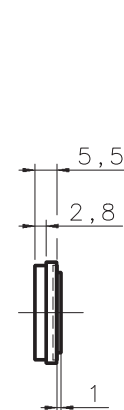
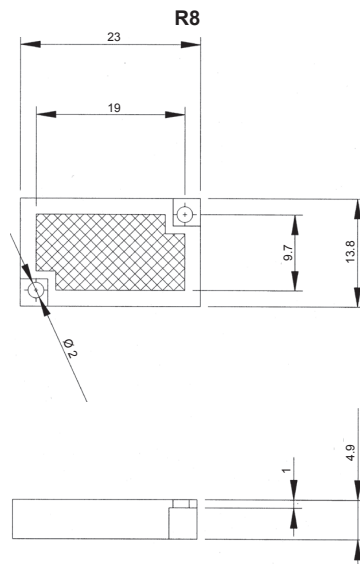
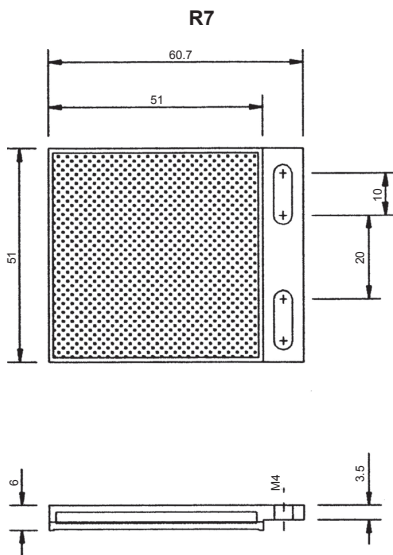
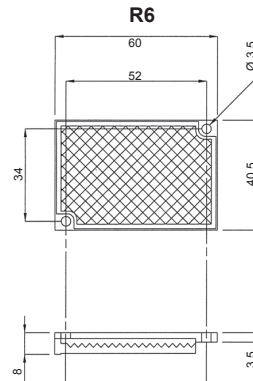
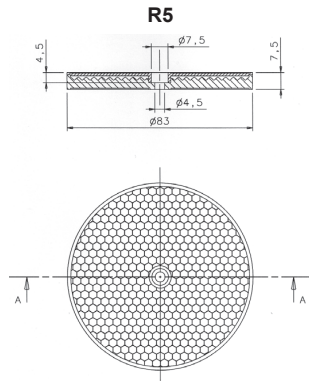
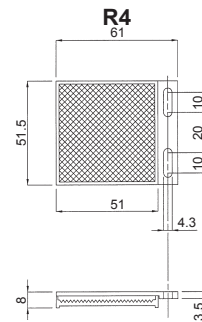
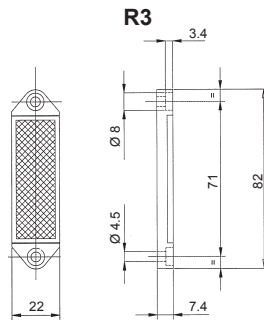
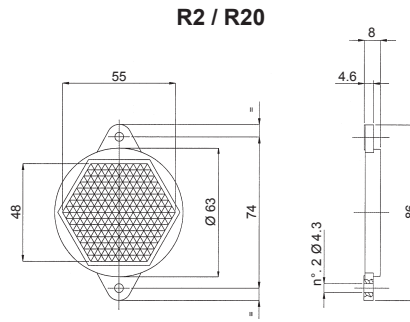
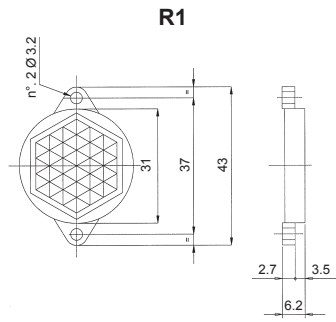

mm

ACCESSORIES

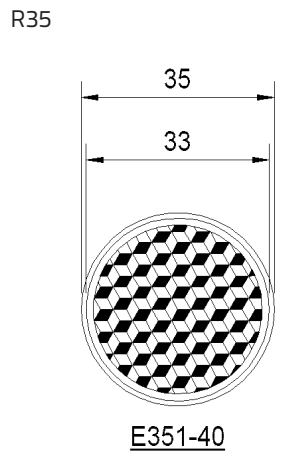
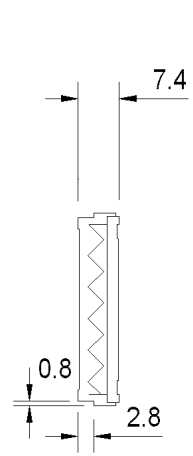
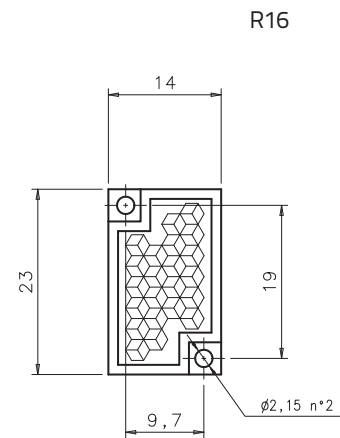
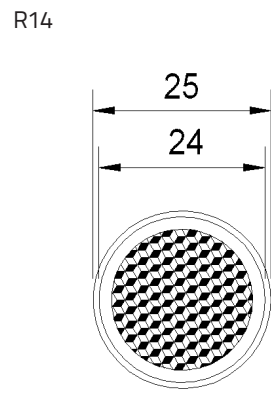
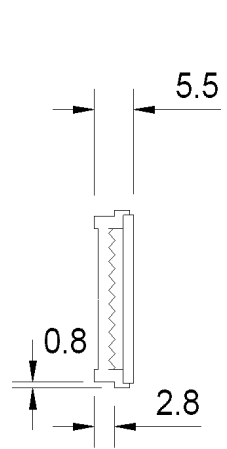
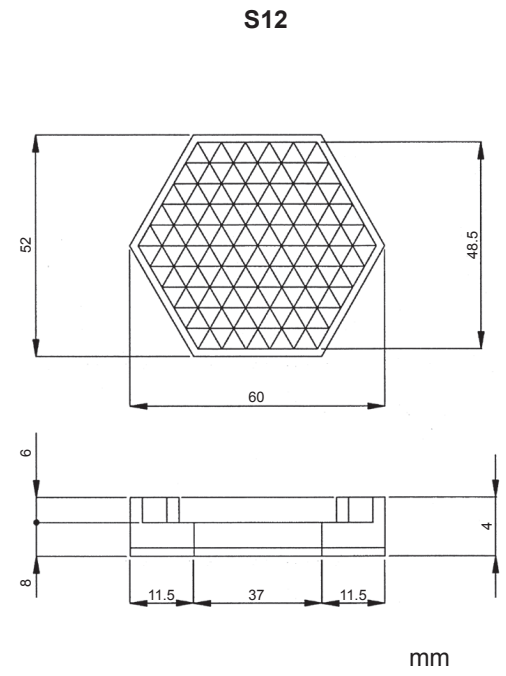
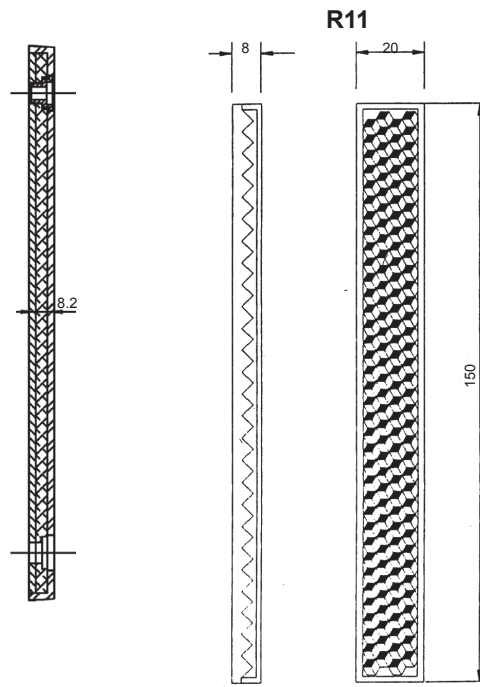
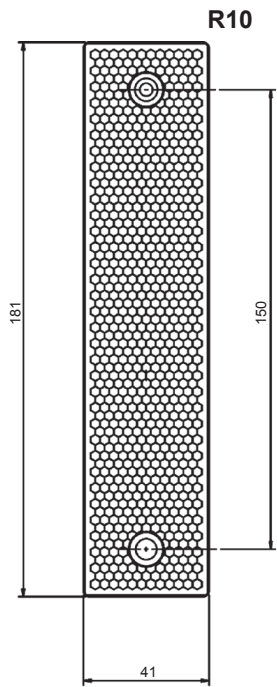

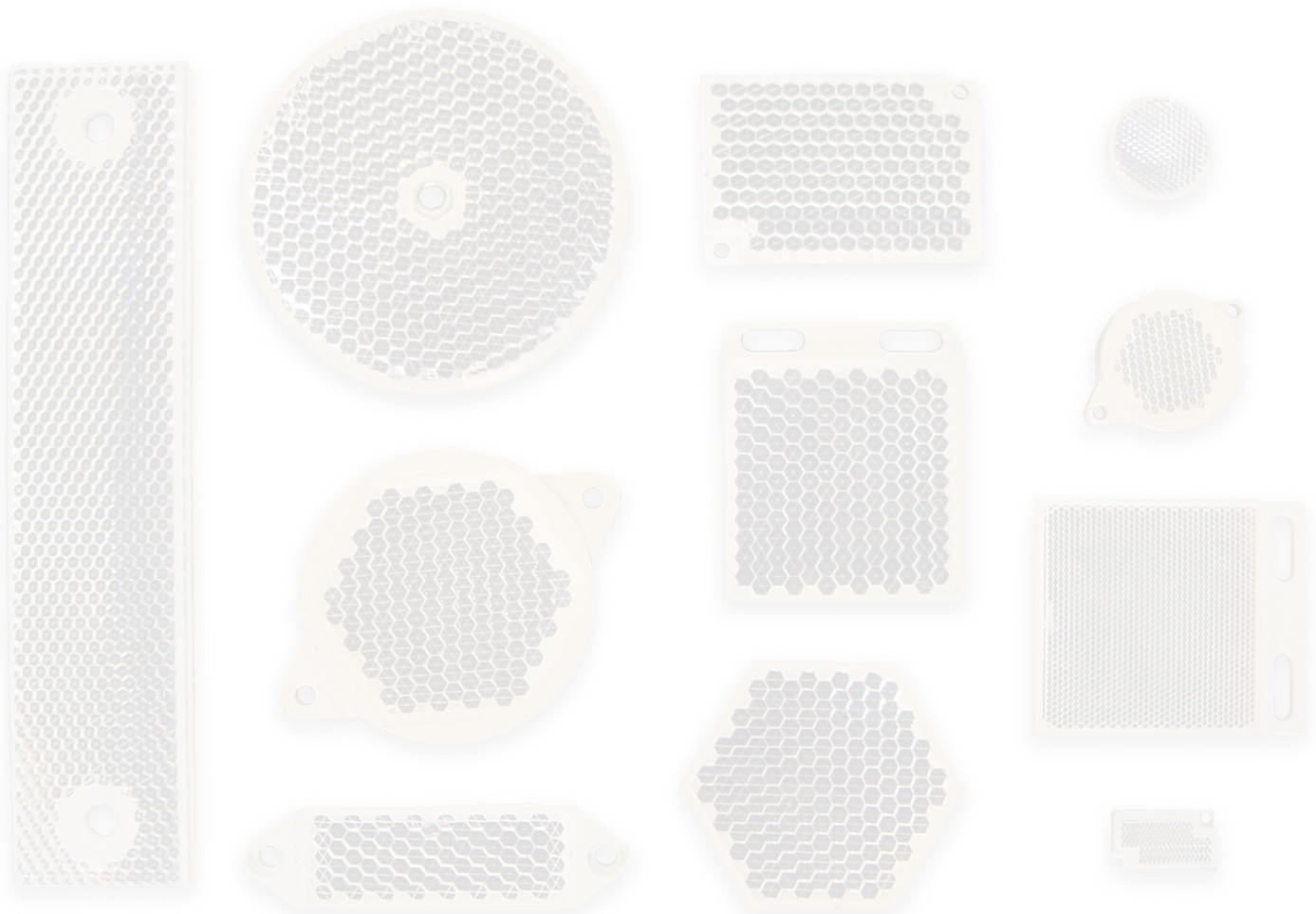



HEADQUARTERS

Datalogic Automation Srl

Via Lavino, 265
40050 Monte San Pietro - Bologna - Italy
Tel: +39 051/6765611
info.automation.it@datalogic.com

BRANCHES AND SALES OFFICES

EUROPE BENELUX

Datalogic Automation Benelux

Newtonweg 3
4104 BK Culemborg - The Netherlands
Tel. +31 345/589489
info.automation.nl@datalogic.com

FRANCE

Datalogic Automation Srl

Succursale en France
Le Parc Technologique de Lyon
333 cours du 3ème Millénaire - Le Pôle
69800 Saint Priest
Tél. +33 (0)4/72476180
info.automation.fr@datalogic.com

GERMANY

Datalogic Automation Srl

Niederlassung Central Europe
Gottlieb-Stoll-Straße 1,
73271 Holzmaden
Tel. +49 7023 7453-100
info.automation.de@datalogic.com

ITALY

Datalogic Automation Italy

Via Lavino, 265
40050 Monte San Pietro - Bologna
Tel. +39 051/6765611
info.automation.it@datalogic.com

Via Taormina 1
20093 - Cologno Monzese (MI) Italy
Tel. +39 02 25151211
info.automation.it@datalogic.com

Via Le Gorrey, 10 11020, Donnas - Aosta
Tel. +39-0125-8128201
info.automation.it@datalogic.com

SPAIN

Datalogic Automation Iberia

Sucursal en España
C/ Frederic Mompou 4 esc A, 4º puerta 3ª
08960 Sant Just Desvern - Barcelona
Tel. +34 (0)93/4772059

NORDIC

Datalogic Automation ab

Höjdrodergatan 21
21239 Malmö - Sweden
Tel. +46 (0)40/385000
info.automation.se@datalogic.com

UNITED KINGDOM

Datalogic Automation UK

Datalogic House
Dunstable Road, Redbourn - Hertfordshire
AL3 7PR
Tel. +44 (0) 1582 791750
info.automation.uk@datalogic.com

TURKEY

Datalogic ADC Turkey

Merkezi İtalya İstanbul Merkez Şubesi Süleyman
Seba Cad. No:48 BJK Plaza A. Blok Kat:4 D.44
34357 - İstanbul - Turkey
Tel. +90 212 396 1550
info.adc.tr@datalogic.com

NORTH AMERICA

Datalogic Automation Inc

511 School House Road
Telford, PA 18969-1196 - United States
Tel. +1-800-BAR-CODE or +1-215-723-0981
info.automation.us@datalogic.com

Datalogic Automation Inc

MACHINE VISION
5775 W Old Shakopee Rd
STE 160, Bloomington, MN 55437
United States
Tel. +1-952-996-9500
info.automation.us@datalogic.com

SOUTH AMERICA

Datalogic Brazil

Avenida Olivio Roncoletta, 465
Bairro Vila Hortolandia Jundiá (SP), Brazil
Tel. +55 11 29232600
info.automation.br@datalogic.com

APAC

Australia-New Zealand

Datalogic Automation Pty Ltd

Unit 130, 45 Gilby Road
Mt Waverley - Victoria, 3149 - Australia
Tel. +61 (0)3/95589299
info.automation.au@datalogic.com

CHINA

Datalogic Automation Asia

2nd Floor, 10 Building, Dayuan Industrial Zone,
No.1, Pingshan 1st Road,
Liuxuan Blvd. Xili, Nanshan District,
518054, Shenzhen, China
Tel: +86 (0)755-8629 6779
info.automation.cn@datalogic.com

R206, 2F, No. 1288 Longdong Avenue,
Pudong New Area,
Shanghai, 201203
Tel: +86 (0)21-5836 6692
info.automation.cn@datalogic.com

Floor 20, Room 2019, Building 2,
16 West Nan San Huan Road
Fengtai District, Beijing
Tel: +86 (0)10-8757 6375
info.automation.cn@datalogic.com

1202, Excellence Build, 128 Yanji Road,
Shibei District, Qingdao, China
Tel: +86 (0)532 55787889

JAPAN

Idec Auto-Id Solutions Corporation

8-10, Shioe 5-chome, Amagasaki Hyogo,
Japan 661-0976
Tel. +81-6-7711-8880
www.idec.com

Rev. 07, 06/2016



9C514100U

Product and Company names and logos referenced may be either trademarks or registered trademarks of their respective companies. We reserve the right to make modifications and improvements.



DATALOGIC
THE VISION IS YOURS

www.datalogic.com